

Energi Savr Node™ for 0-10 V

Energi Savr Node™ with Softswitch®

The Energi Savr Node™ (ESN) family is a group of modular products for the control of lighting and other loads. This document describes the following products:

- ESN unit for 0-10 V (models QSN-4T16-S and QSN-4T16-S-347 — 0-10 V Control/Softswitch®)
- Softswitch® ESN unit (models QSN-4S16-S and QSN-4S16-S-347 — Softswitch®)

Features

- Default configuration requires no commissioning.
- Programming using integral interface on the ESN unit.
- Four occupancy sensor inputs for automated control of lights in 4 zones.
- Four daylight sensor inputs automatically adjust light levels based on the amount of natural light entering through the windows.
- Four IR receiver inputs for personal control.
- Four inputs for IEC PELV/NEC® Class 2 dry contact switches.
- Includes QS control link for seamless integration of lights, control stations, and QS sensor modules.
- Softswitch® technology yields 1,000,000 cycle relay lifetime.
- Contact Lutron for compatibility with Quantum® System.

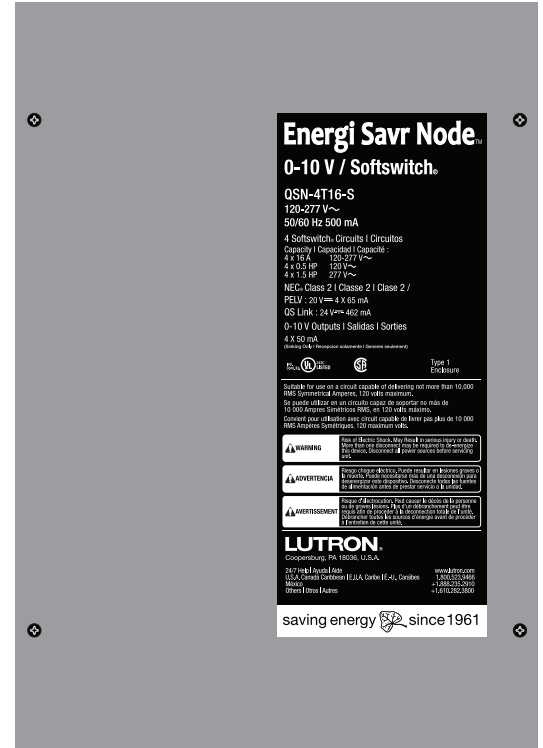

System Example

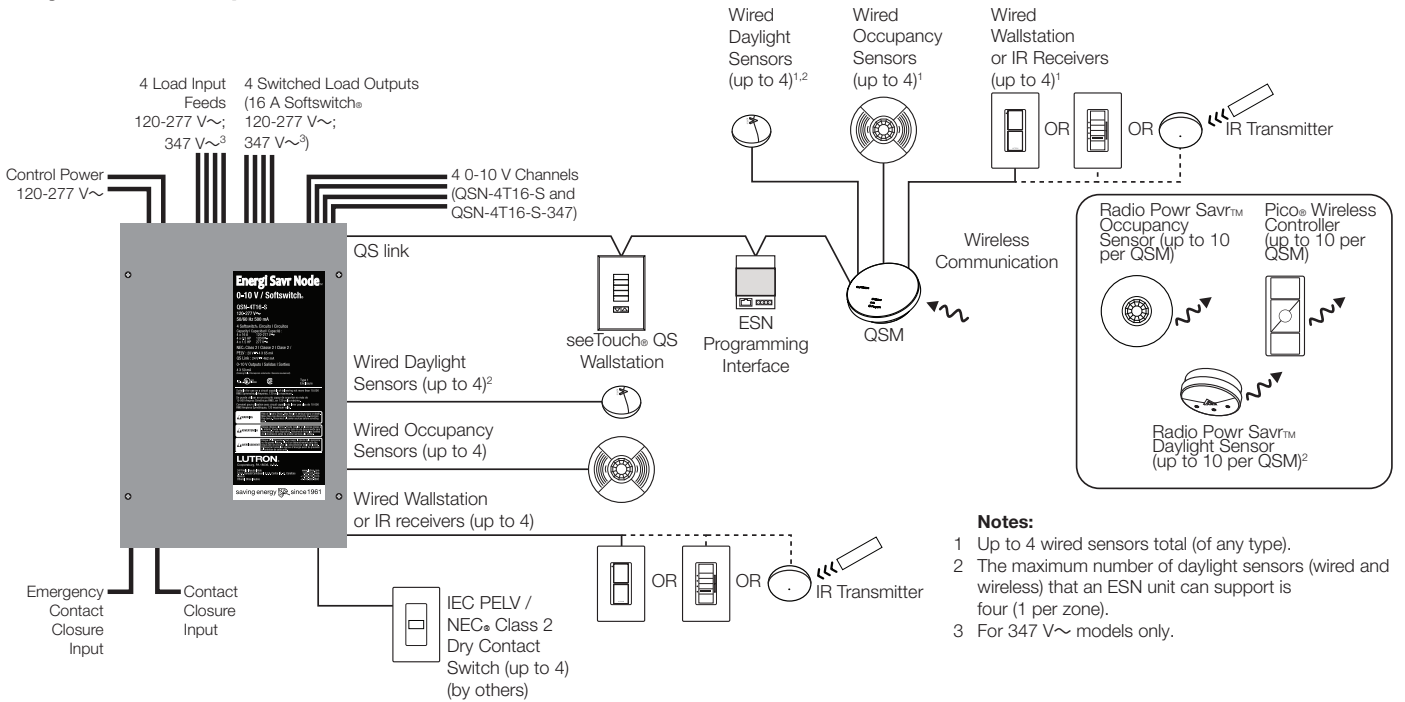

Notes:

- 1 Up to 4 wired sensors total (of any type).
- 2 The maximum number of daylight sensors (wired and wireless) that an ESN unit can support is four (1 per zone).
- 3 For 347 V~ models only.

Job Name:	Model Numbers:
Job Number:	

Specifications

Power

- Control Power: 120 V~; 220-240 V~; 277 V~ 50/60 Hz
- Lightning strike protection meets ANSI/IEEE standard 62.41-1991. Can withstand voltage surges of up to 6000 V~ and current surges of up to 3000 A
- Current draw: 0.5 A max
- 10-year power failure memory: restores lighting to levels prior to power interruption
- Latching relays keep previously illuminated zones on when control power feed is lost

Standards

- UL Listed
- CSA
- Lutron Quality Systems registered to ISO 9001:2008

Environment

- Ambient Temperature Operating Range: 32 °F to 104 °F (0 °C to 40 °C)
- Relative humidity: less than 90% non-condensing
- For indoor use only
- Meets NEC® requirements for installation in “other space used for environmental air”

Terminal Wiring

- Control Power Wiring: 14 AWG to 12 AWG (2.5 mm² to 4.0 mm²)
- Load Wiring: 14 AWG to 12 AWG (2.5 mm² to 4.0 mm²)
- 0-10 V Wiring: 20 AWG to 12 AWG (0.5 mm² to 4.0 mm²)
- Input Group Wiring: 20 AWG to 12 AWG (0.5 mm² to 4.0 mm²) — maximum wire run length to each input not to exceed 150 ft (46 m)
- QS Link Wiring: 22 AWG to 12 AWG (0.5 mm² to 4.0 mm²)
- Contact Closure Wiring: 20 AWG to 12 AWG (0.5 mm² to 4.0 mm²)

Physical Design and Mounting

- NEMA Type 1, IP-20 protection
- Surface mount

Load Types (relay ratings)

- 16 A Tungsten, 120 to 277 V~
- 16 A AC General Use, 120 to 277 V~
- 16 A Electric Discharge Lamp (ballast), 120 to 277 V~, 347 V~ (347 V~ models only)
- 16 A Inductive, 120 to 277 V~
- 0.5 HP, 120 V~
- 1.5 HP, 220 to 277 V~

Input Default Associations

	Inputs/Outputs	Zone 1	Zone 2	Zone 3	Zone 4
Group 1	Occ	X			
	Photo	X			
	IR	X			
	Switch	X			
Group 2	Occ		X		
	Photo		X		
	IR		X		
	Switch		X		
Group 3	Occ			X	
	Photo			X	
	IR			X	
	Switch			X	
Group 4	Occ				X
	Photo				X
	IR				X
	Switch				X
	CCI	X	X	X	X
	Emergency CCI	X	X	X	X

Softswitch® — 120 V~ to 277 V~, 347 V~ (347 V~ models only)

- Softswitch® relay is rated for 16 A continuous use per channel, which is the maximum continuous load for a 20 A Overcurrent Protection Device (Branch Breaker).
- Patented Softswitch® circuit eliminates arcing at mechanical contacts when loads are switched. Extends relay life to an average of 1,000,000 cycles (on/off) for resistive, capacitive, or inductive sources.
- Relay is mechanically held.

0–10 V Product Ratings (QSN-4T16-S and QSN-4T16-S-347)

- Each output sinks up to 50 mA maximum.
- Each output sinks current only (load device must provide 10 V supply).
- Provides an IEC PELV/NEC® Class 2 isolated 0-10 V output signal that conforms to IEC 60929.

Job Name:	Model Numbers:
Job Number:	

Specifications (continued)

Occupancy Sensors

- Up to 16 occupancy sensors can be programmed to the Energi Savr Node™ device.
- Manual Programming: up to 4 occupancy sensors wired directly to the Energi Savr Node™ device, up to 4 occupancy sensors wired to a QS Sensor Module (QSM), and up to 10 wireless occupancy sensors through the same QSM; the total programmed to the Energi Savr Node™ device cannot exceed 16.
- HDD (iPod/iPhone) Programming: up to 16 occupancy sensors from any source (wired directly to the Energi Savr Node™ device, wired to any other Energi Savr Node™ device, or wired/wireless from any QSM on the QS link); the total programmed to the Energi Savr Node™ device cannot exceed 16.
- Use Lutron® occupancy sensors to control one or more zones.
- Use Lutron® occupancy sensors in vacancy mode to automatically turn the lights off in an area after it becomes vacant.
- Each zone can be programmed to automatically turn the lights on when occupied and turn the lights off when vacant.
- Each wired occupancy input can power one Lutron® occupancy sensor.
- Each occupied scene and unoccupied scene can be programmed independently.
- Lutron® occupancy sensors can be programmed to automatically turn the lights on in area when it becomes occupied and turn the lights off in an area after it becomes vacant.
- Each of the four occupancy inputs can power one Lutron® occupant sensor.
- Each area's occupied scene and unoccupied scene can be programmed independently.
- Occupancy sensor must provide a dry contact closure or solid-state output.
- Additional occupancy sensors can be used with the Energi Savr Node™ device. Refer to the "Programming Options and Features" table for system rules.

seeTouch® QS Controls

- seeTouch® QS wallstations can be configured to control ESN unit scenes or zones.
- In zone toggle mode, zone buttons can be assigned to one or more zones on any ESN unit connected to the QS Link.
- In scene mode, wallstations can be assigned to one or more ESN units connected to the QS Link.

Apple, iPhone and iPod touch are trademarks of Apple Inc., registered in the U.S. and other countries.

- LED indicator displays zone or scene status.

Table 1: seeTouch® QS Wallstation Configurations

Wallstation Function	# Buttons				
	1	2	3	5	7
Zone Toggle	✓	✓	✓	✓	✓
Scene	1, Off (toggle)	1, Off	1, 2 Off	1-4, Off	N/A

IR Wallstation or Receiver Input

- Four inputs for IR receivers or wallstations for control of lighting zones can be connected directly to the ESN unit
- Use Lutron® CC-1BRL-WH or CC-4BRL-WH wallstations to control one or more zones.
- Use Lutron® EC-DIR-WH or EC-IR-WH ceiling mount sensors to control one or more zones.
- Up to four additional wired wallstations or IR receivers can be assigned when associated with a QSM.
- Associate additional QSMs and sensors/controls with ESN unit when programming with an *Apple iPod touch* or *iPhone*. Refer to "Programming Options" section for details.

Daylight Sensors

- Lutron® daylight sensors allow daylight harvesting with programmable effect on light output.
- Four daylight sensors can be connected directly to the ESN unit.
- Use Lutron® EC-DIR-WH sensors to control one or more zones.
- Alternatively, up to four sensors (Lutron® Wired Daylight Sensors or Radio Powr Savr™ Daylight Sensors) can be assigned when associated with a QSM.
- The maximum number of Lutron® daylight sensors (wired or wireless), either wired directly to the unit or indirectly (associated with a QSM) cannot exceed four.
- Associate additional QSMs and sensors/controls with ESN unit when programming with an *Apple iPod touch* or *iPhone*. Refer to "Programming Options" section for details.

Contact Closure Input (CCI)

Default behavior:

- Activate scenes using momentary or maintained closures from an external device such as a timeclock. (continued)

Job Name:	Model Numbers:
Job Number:	

Specifications (continued)

- Start or stop Afterhours Mode using a maintained closure.
- The attached device must provide a dry contact closure or solid-state output.
- Configurable for Normally-Open (NO) or Normally-Closed (NC) operation.
- Input is miswire-protected up to 36 V_{rms}.

Emergency Contact Closure Input

- By default, contact closure input from Lutron® Emergency Lighting Interface (LUT-ELI-3PH), security, or fire alarm systems turns all zones on to full output when emergency state is detected.
- Emergency contact closure input is normally closed (NC). The ESN unit is shipped with a jumper pre-installed.
- Response of each zone is configurable.
- Attached devices, by default, will go to maximum output and ignore control inputs.
- No operations will be allowed until emergency signal is cleared.
- The attached device must provide a dry contact closure or solid-state output.
- Input is miswire-protected up to 36 V_{rms}.
- Emergency CCI cannot control other ESN units.

Functionality with GRAFIK Eye® QS

- ESN unit follows GRAFIK Eye® QS scene activations when associated with the GRAFIK Eye® QS.
- ESN unit responds to commands initiated by the GRAFIK Eye® QS astronomic time clock when associated with the GRAFIK Eye® QS.
- ESN unit operates in afterhours mode when associated with a GRAFIK Eye® QS that is in afterhours mode.

Functionality with QSE-IO

- ESN unit responds to scene commands initiated by the QSE-IO, if the QSE-IO DIP switches have been set to either scene selection mode, zone toggle mode, partition mode, or occupancy sensor mode.

Functionality with QSE-CI-NWK-E

- Integrate ESN unit with touchscreens, PCs, A/V systems, or other digital systems and devices.
- Recall scenes and set/adjust zone levels.

Apple, iPhone and iPod touch are trademarks of Apple Inc., registered in the U.S. and other countries.

IEC PELV/NEC® Class 2 Dry Contact Switches

- Four inputs for IEC PELV/NEC® Class 2 dry contact switches can be assigned to turn on and off one or more zones.
- Configure for momentary or maintained operation.

QS Link Limits

- Each ESN unit can provide up to 14 Power Draw Units (PDUs) for other QS devices. Refer to the QS Link Power Draw Unit specification submittal (Lutron® P/N 369405) for more information concerning PDUs.
- The QS Link can have up to 100 devices and 100 zones.
- Each ESN unit counts as 1 device towards the 100 device limit.
- Each ESN unit counts as 4 zones towards the 100 zone limit.

QSM (QS Sensor Module)

- Use the QSM to integrate Radio Powr Savr™ Occupancy sensors, Radio Powr Savr™ Daylight sensors, and Pico® Wireless Controllers to control zones on the ESN unit.
- Associate 1 QSM per ESN unit with manual programming.
- Associate multiple QSMs per ESN unit with *Apple iPod touch* or *iPhone* programming (requires QSE-CI-AP-D and Wi-Fi router). See "Programming Options" for details.
- Assign up to 10 Radio Powr Savr™ Occupancy sensors per ESN unit via QSM.
- Assign up to 4 Radio Powr Savr™ Daylight sensors per ESN unit via QSM.
- Assign up to 10 Pico® Wireless Controllers per ESN unit via QSM.
- The sensors and Pico® Wireless Controllers associated with the QSM should be mounted within 60 ft (18 m) line of sight, or 30 ft (9 m) through walls, of the QSM.
- Wire and power up to 4 wired sensors per QSM
 - Daylight Sensors
 - Occupancy Sensors
 - Infrared (IR) Receivers or Wallstations
- Refer to QSM Specification Submittal for more information.

Job Name:

Model Numbers:

Job Number:

Programming Options

Manual Programming:

- Use buttons on the front of the ESN unit.
- Use manual programming in installations with only one ESN unit and with one QSM or fewer on the QS link.

HHD Programming

- Requires ESN Programming Interface (QSE-CI-AP-D).
- Requires *Apple iPod touch* or *iPhone* mobile digital device.
- Use the intuitive programming application for the *Apple iPod touch* or *iPhone* to program systems with multiple ESN units and QSMs in the QS link.
- Wireless router only required for programming with an *Apple iPod touch* or *iPhone*.

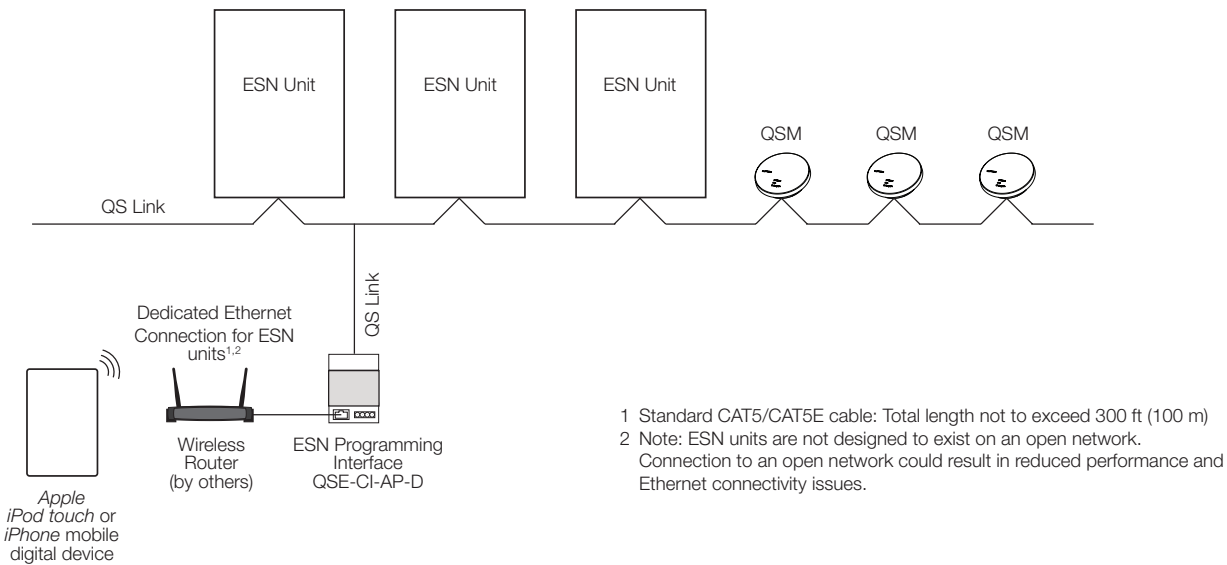

- Wireless router may be removed for normal operation.
- Ethernet connection may be made via an ESN Programming Interface (QSE-CI-AP-D) or an ESN QS unit with integral Ethernet jack.
- Lutron recommends that an ESN Programming Interface (or ESN QS unit with Ethernet jack) be wired to an Ethernet jack in the space for ease of access and proximity to power for the wireless router.
- Works with any standard wireless router that supports multicast packets.
- *Apple iPod touch* or *iPhone* can program all ESN QS units connected to an ESN Programming Interface via the QS Link (except when part of a Quantum® system).
- ESN app is required and is available from the *Apple iTunes Store* online marketplace.

Apple, iPhone, iPod touch and iTunes Store are trademarks of Apple Inc., registered in the U.S. and other countries.

<p>Job Name:</p>	<p>Model Numbers:</p>
<p>Job Number:</p>	

Programming Options and Features

	Manual Programming	HHD Programming: <ul style="list-style-type: none"> • Requires ESN Programming Interface QSE-CI-AP-D • Requires Apple iPod touch or iPhone mobile digital device
ESN units connected to 1 QS Link	Not more than 1	Multiple—100 QS devices and 100 zone limits apply
QSMs connected to 1 QS link	Not more than 1	Multiple—100 QS devices limit applies

Wired Occupancy Sensors

System Limits	4 connected directly to ESN unit Up to 4 wired to QSM	Up to 100 total occupancy sensors per QS link (wired + wireless)
Can be assigned to...	Any zone(s) on the ESN unit	Zones on ESN unit or share to other ESN units on same QS link
Occupancy Dependency Supported	No	Yes

Wireless Occupancy Sensors

System Limits	Associate 10 occupancy sensors to QSM to control zones on the ESN unit	Up to 100 total occupancy sensors per QS link (wired + wireless)
Can be assigned to...	Any zone(s) on the ESN unit	Zones on ESN unit or share to other ESN units on same QS link
Occupancy Dependency Supported	No	Yes

Wired Daylight Sensors

System Limits	Maximum of 1 daylight sensor per zone 4 connect directly to the ESN unit Additional daylight sensors can connect to the QSM	Maximum of 2 daylight sensors per zone Up to 100 total daylight sensors per QS link (wired + wireless)
Can be assigned to...	Any zone(s) on the ESN unit	Zones on ESN unit or share to other ESN units on same QS link
Disable daylighting in Scenes	No	Yes

Wireless Daylight Sensors

System Limits	Maximum of 1 daylight sensor per zone Associate wireless daylight sensors to the QSM	Maximum of 2 daylight sensors per zone Associate up to 10 wireless daylight sensors per QSM Up to 100 total daylight sensors per QS link (wired + wireless)
Can be assigned to...	Any zone(s) on the ESN unit	Zones on ESN unit or share to other ESN units on same QS link
Disable daylighting in Scenes	No	Yes

Apple, iPhone, and iPod touch are trademarks of Apple Inc., registered in the U.S. and other countries.

Job Name:	Model Numbers:
Job Number:	

Programming Options and Features (continued)

Manual Programming

HHD Programming:

- Requires ESN Programming Interface QSE-CI-AP-D
- Requires Apple iPod touch or iPhone mobile digital device

Pico® Wireless Controllers

System Limits	Associate 10 Pico® wireless controllers to QSM to control zones on the ESN unit	Up to 100 total controls per QS link (wired wallstations, Pico® wireless controllers, IR receivers)
Can be assigned to...	Any zone on the local ESN unit	Zones on ESN unit or share to other ESN units on same QS link

IR Receivers and Wallstations

System Limits	4 connect directly to the ESN unit Up to 4 wired to the QSM	Up to 100 total controls per QS link (wired wallstations, Pico® wireless controllers, IR receivers)
Can be assigned to...	Any zone on the local ESN unit	Zones on ESN unit or share to other ESN units on same QS link

NEC® dry contact Switches Inputs

Can be assigned to...	Any zone(s) on the connected ESN	Any zone(s) on the connected ESN
-----------------------	----------------------------------	----------------------------------

Contact Closure Input

Can be assigned to...	Any zone(s) on the ESN unit	Any or all local ESN unit zones
Functions	<ul style="list-style-type: none"> • Sweep to off • Enable/disable afterhours • Turn on to preset and turn off 	<ul style="list-style-type: none"> • Sweep to off • Enable/disable afterhours • Turn on to preset and turn off • Load shed
Afterhours Configuration	afterhours timeout- 15 minutes blink-warn timeout- 5 minutes	Afterhours timeout and blink-warn timeouts are configurable

Emergency Contact Closure Input

Can be assigned to...	Any zone(s) on the ESN unit	Any or all local ESN zones
Emergency Light level	Configurable	Configurable

Apple, iPhone, and iPod touch are trademarks of Apple Inc., registered in the U.S. and other countries.

Job Name:	Model Numbers:
Job Number:	

Programming Options and Features (continued)

Manual Programming	HHD Programming: <ul style="list-style-type: none"> • Requires ESN Programming Interface QSE-CI-AP-D • Requires <i>Apple iPod touch</i> or <i>iPhone</i> mobile digital device
---------------------------	---

seeTouch® QS wallstations

Scene Keypads assigned to...	Any zone(s) on the ESN unit	Any zone(s) on one or more ESN units on the QS link
Scene + off keypads assigned to...	Any zone(s) on the ESN unit	Any zone(s) on one or more ESN units on the QS link
Zone toggle keypad buttons assigned to...	Any zone(s) on the ESN unit	Any zone(s) on on or more ESN units on the link
Change Keypad to Scene or Zone	Yes	Yes
Changing keypads to shade, panic, fine tune	No	Yes

Zone Configuration Parameters

Load type	0-10, 10-0, or switched	0-10, 10-0, or switched
High-end trim	Adjustable	Adjustable
Low-end trim	Adjustable	Adjustable
Absolute minimum level	Adjustable	Adjustable

Scenes

Available scenes	Scenes 1-16	Scenes 1-16
------------------	-------------	-------------

GRAFIK Eye® QS	N/A	Share scenes, timeclock events, or afterhours events to ESN units on QS Link
-----------------------	-----	--

QSE-IO	Scene, zone toggle, occupancy	Scene, zone toggle, occupancy
---------------	-------------------------------	-------------------------------

QSE-CI-NWK-E	Yes	Yes
---------------------	-----	-----

Apple, iPhone, and iPod touch are trademarks of Apple Inc., registered in the U.S. and other countries.

Job Name:	Model Numbers:
Job Number:	

Mechanical Dimensions

All dimensions shown as in (mm)

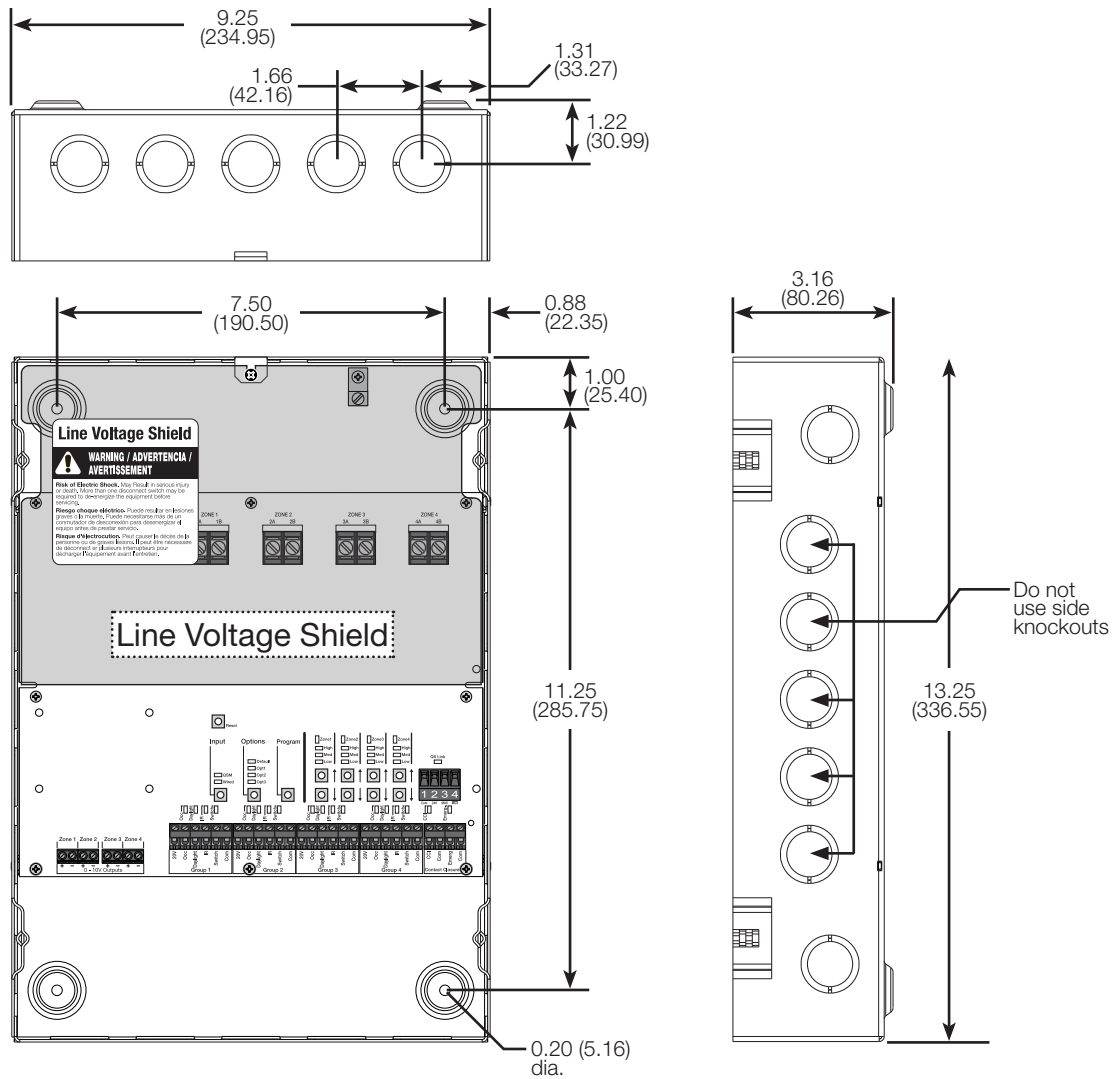

Job Name:	Model Numbers:
Job Number:	

Wiring: QS Link

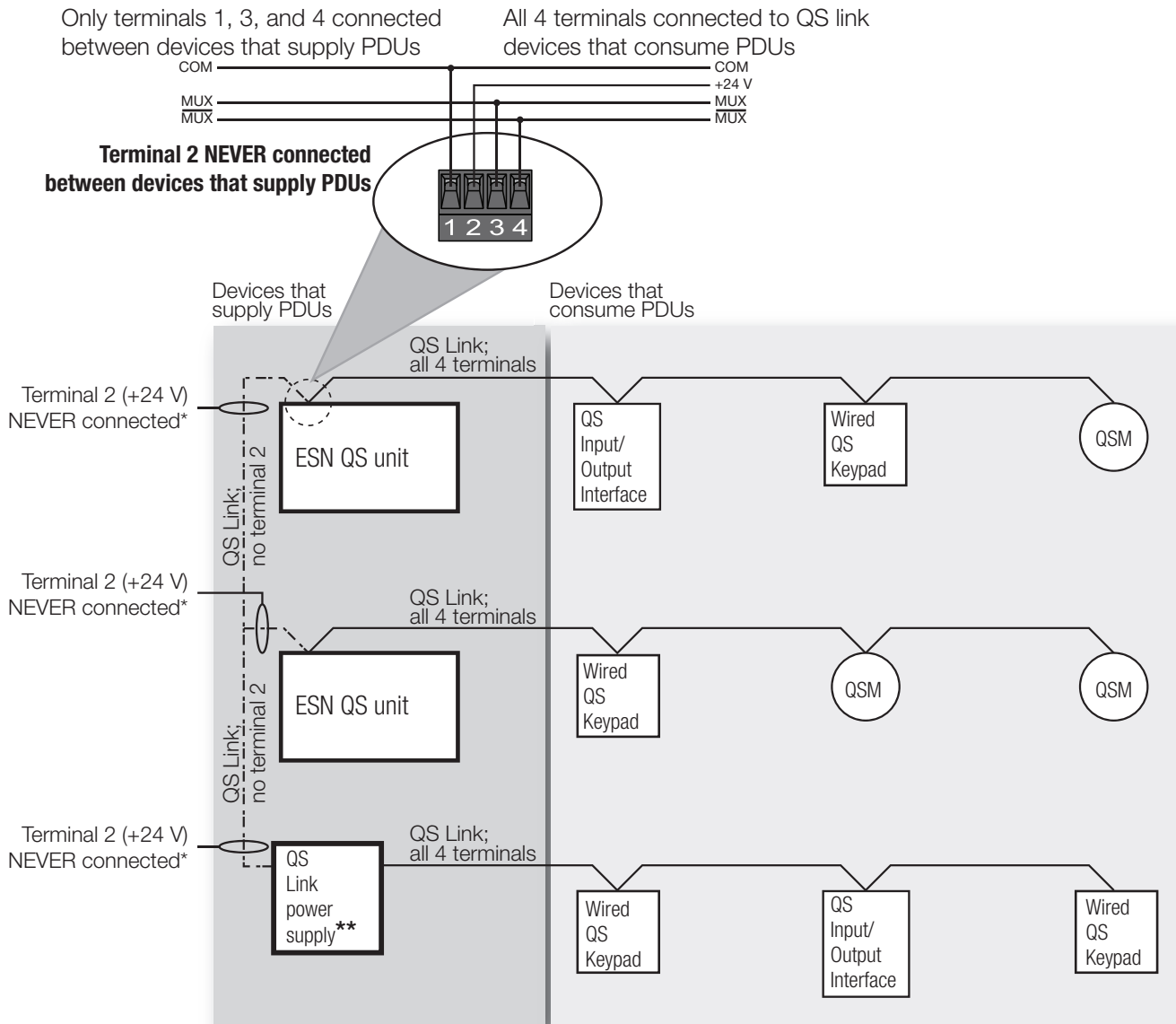

QS Link Wiring Rules

- * Terminal 2 (+24 V) should NEVER be connected between devices that supply PDUs.
- ** For QS Link power supply wiring connection details, refer to the installation instructions for the specific power supply model being used.

Job Name:	Model Numbers:
Job Number:	

Wiring: IEC PELV/NEC® Class 2 Inputs

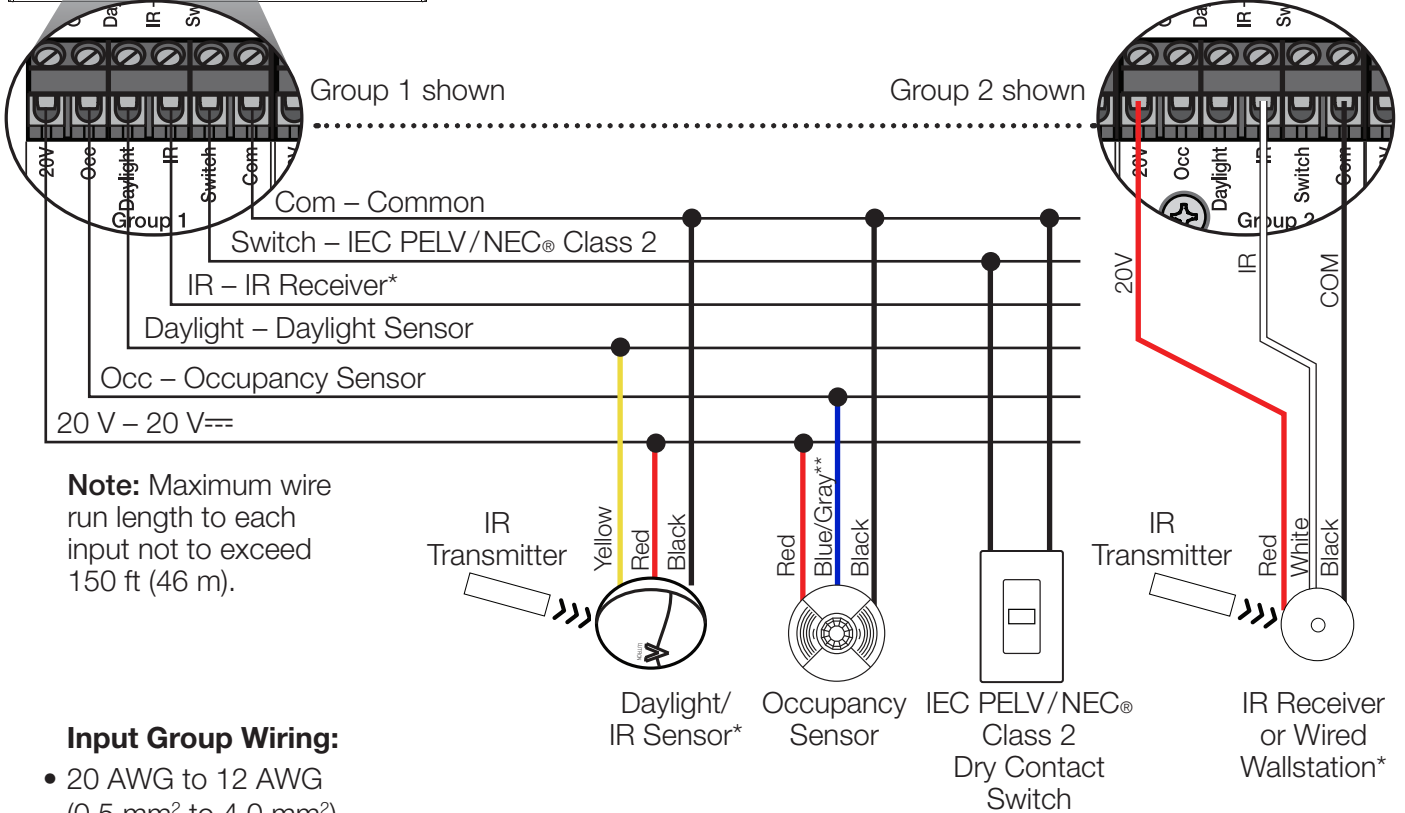
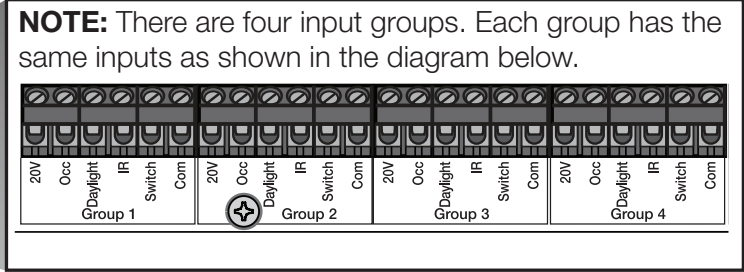
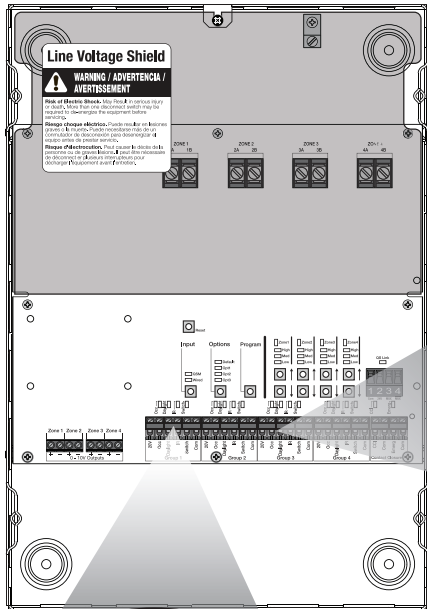

Note: Maximum wire run length to each input not to exceed 150 ft (46 m).

Input Group Wiring:

- 20 AWG to 12 AWG (0.5 mm² to 4.0 mm²)
- Strip length: 1/4 in (6 mm)
- Torque: 5 in•lb (0.5 N•m)

* **Note:** Only one IR device may be connected per input. If the IR signal from a daylight sensor is connected, a wall control may not be connected to the same input, and vice-versa.

**Connect the gray wire on -R model occupancy sensors.

Job Name:	Model Numbers:
Job Number:	

Wiring: Contact Closure Inputs (CCI and Emerg)

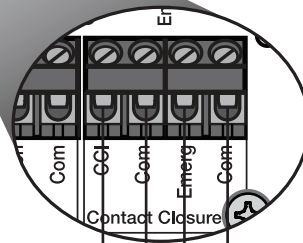
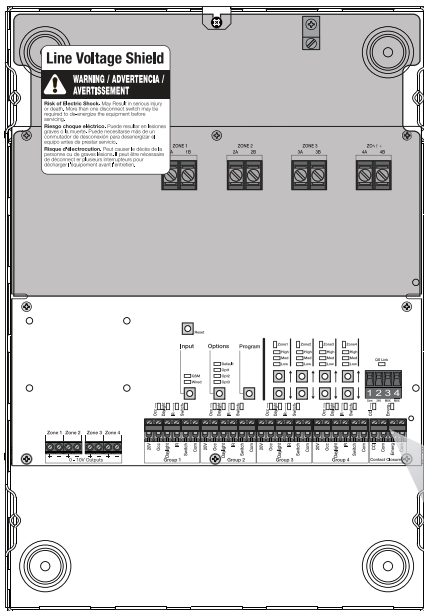

CCI – Contact Closure Input
Com – Common

Com – Common
Emerg – Emergency

Contact Closure Wiring:

- 20 AWG to 12 AWG (0.5 mm² to 4.0 mm²)
- Strip length: 1/4 in (6 mm)
- Torque: 5 in•lb (0.5 N•m)

<p>Job Name:</p> <p>Job Number:</p>	<p>Model Numbers:</p>
--	-----------------------

Wiring Diagram: Example A – 4 circuits, multiple feeds

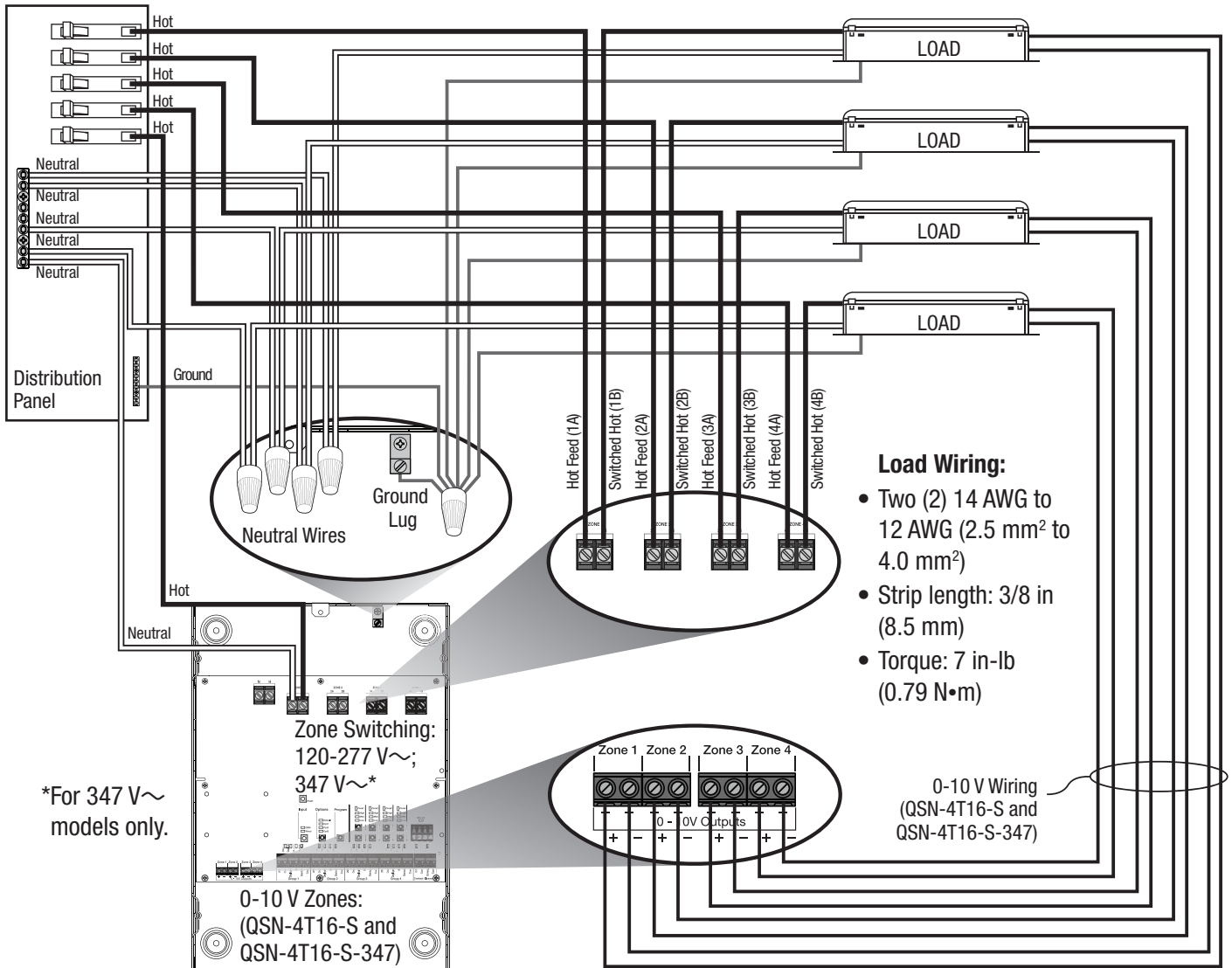

*For 347 V~ models only.

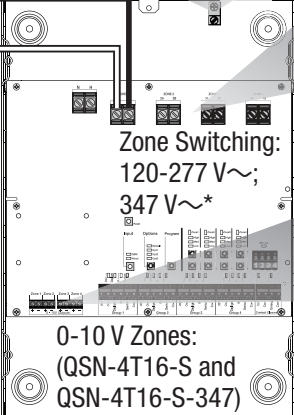

- 0-10 V Wiring (QSN-4T16-S and QSN-4T16-S-347)**
- 20 AWG to 12 AWG (0.5 mm² to 4.0 mm²)
 - Strip length: 1/4 in (6 mm)
 - Torque: 5 in-lb (0.5 N•m)
 - Connect only IEC PELV/NEC® Class 2 circuits or connect only non-IEC PELV/NEC® Class 2 circuits to 0-10 V zones 1-4.
 - 0-10 V zones 1-4 are not isolated from each other.
 - Negative (-) terminals are not internally connected to each other—both positive (+) and negative (-) connections must be made.
 - Follow all national and local codes for separation requirements.

Job Name:	Model Numbers:
Job Number:	

Wiring Diagram: Example B – 4 circuits, single feed

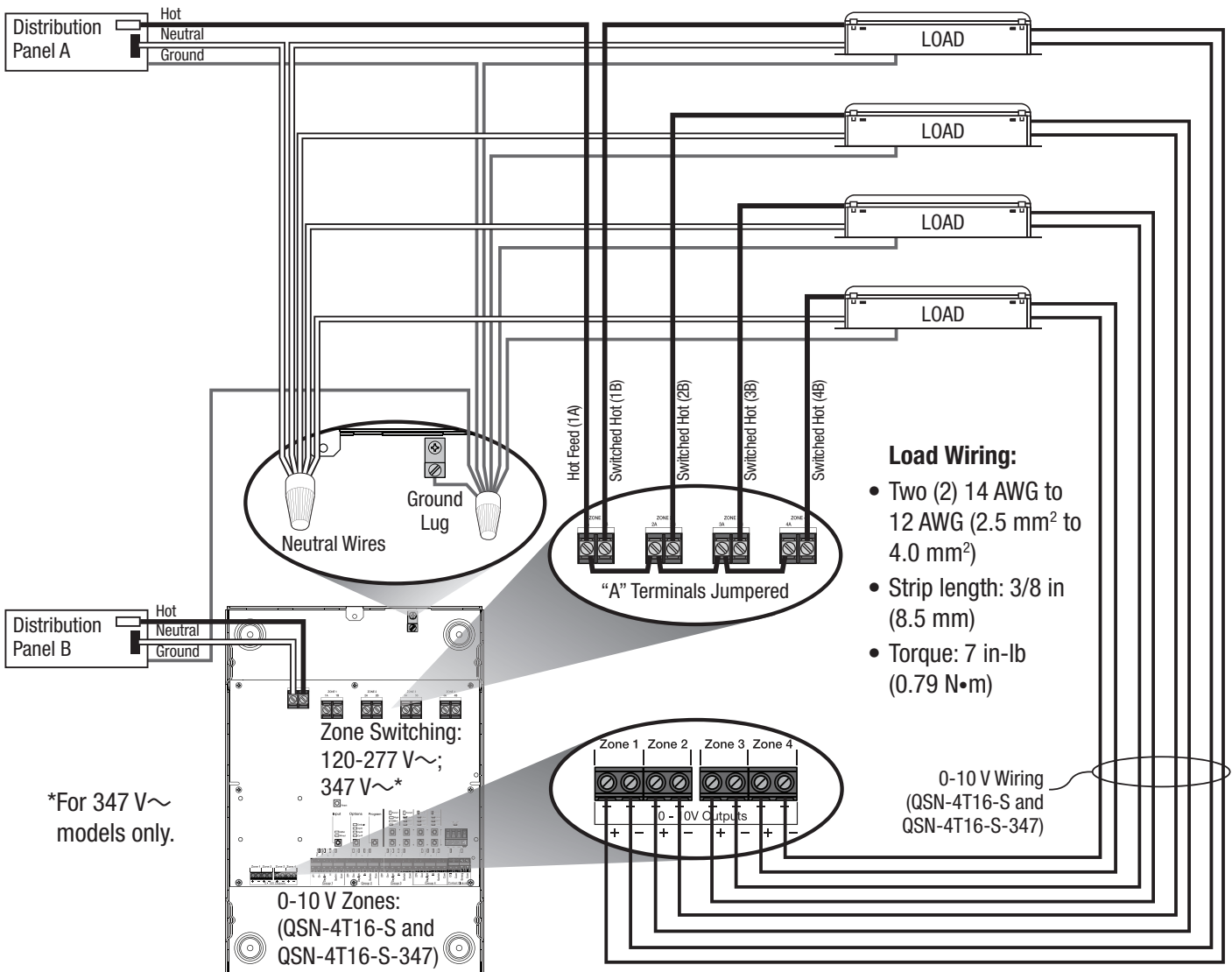

- Load Wiring:**
- Two (2) 14 AWG to 12 AWG (2.5 mm² to 4.0 mm²)
 - Strip length: 3/8 in (8.5 mm)
 - Torque: 7 in-lb (0.79 N•m)

*For 347 V~ models only.

Zone Switching:
120-277 V~;
347 V~*

0-10 V Zones:
(QSN-4T16-S and
QSN-4T16-S-347)

0-10 V Wiring (QSN-4T16-S and QSN-4T16-S-347)

- 20 AWG to 12 AWG (0.5 mm² to 4.0 mm²)
- Strip length: 1/4 in (6 mm)
- Torque: 5 in-lb (0.5 N•m)
- Connect only IEC PELV/NEC® Class 2 circuits or connect only non-IEC PELV/NEC® Class 2 circuits to 0-10 V zones 1-4.
- 0-10 V zones 1-4 are not isolated from each other.
- Negative (-) terminals are not internally connected to each other—both positive (+) and negative (-) connections must be made.
- Follow all national and local codes for separation requirements.