

Continuous-flex Power Cables with SpeedTec DIN Connector

Catalog Numbers 2090-CPBM7DF-10AF_{xx}, 2090-CPBM7DF-08AF_{xx},
2090-CPWM7DF-10AF_{xx}, 2090-CPWM7DF-08AF_{xx}

Topic	Page
About Continuous-flex Power and Power with Brake Cables	1
Important User Information	2
Before You Begin	3
Install Cables	4
Schematics and Connector Pinouts for Cables	6
Specifications	7
Additional Resources	8

About Continuous-flex Power and Power with Brake Cables

Continuous-flex motor power cables, with or without brake connections, can be repeatedly flexed within a specified bend radius when properly installed. The cables have circular SpeedTec connectors at the motor end, and flying leads at the drive end.

Important User Information

Solid state equipment has operational characteristics differing from those of electromechanical equipment. Safety Guidelines for the Application, Installation and Maintenance of Solid State Controls, publication [SGI-1.1](#), is available from your local Rockwell Automation sales office or online at <http://www.rockwellautomation.com/literature>) describes some important differences between solid state equipment and hard-wired electromechanical devices. Because of this difference, and also because of the wide variety of uses for solid state equipment, all persons responsible for applying this equipment must satisfy themselves that each intended application of this equipment is acceptable.





In no event will Rockwell Automation, Inc. be responsible or liable for indirect or consequential damages resulting from the use or application of this equipment.

The examples and diagrams in this manual are included solely for illustrative purposes. Because of the many variables and requirements associated with any particular installation, Rockwell Automation, Inc. cannot assume responsibility or liability for actual use based on the examples and diagrams.

No patent liability is assumed by Rockwell Automation, Inc. with respect to use of information, circuits, equipment, or software described in this manual.

Reproduction of the contents of this manual, in whole or in part, without written permission of Rockwell Automation, Inc., is prohibited.

Throughout this manual, when necessary, we use notes to make you aware of safety considerations.

	WARNING: Identifies information about practices or circumstances that can cause an explosion in a hazardous environment, which may lead to personal injury or death, property damage, or economic loss.
	ATTENTION: Identifies information about practices or circumstances that can lead to personal injury or death, property damage, or economic loss. Attentions help you identify a hazard, avoid a hazard and recognize the consequences.
	SHOCK HAZARD: Labels may be on or inside the equipment, for example, drive or motor, to alert people that dangerous voltage may be present.
	BURN HAZARD: Labels may be on or inside the equipment, for example, drive or motor, to alert people that surfaces may reach dangerous temperatures.
IMPORTANT	Identifies information that is critical for successful application and understanding of the product.

Before You Begin

Remove all packing material from within and around the item. After unpacking, verify the catalog number against the purchase order, and visually inspect the cable and each connector for damage. If necessary, notify the carrier of any shipping damage immediately.

Cables are stored and shipped in a coil, and will retain this shape unless you allow the cable to straighten itself. To straighten a cable, hang a short cable from its mid-point or lay a long cable on the floor in a straight line. Any coiling that persists in the cable should relax within the next 24 hours. Doing this results in a cable that is easier to install.

Observe the following precautions when installing the cables in a servo system. Failure to observe these safety notices could result in personal injury or damage to the motor and equipment.



ATTENTION: Arcing or unexpected motion can occur if the power, brake, or feedback cables are connected or disconnected while power is applied to the drive. Always remove power to the servo drive before connecting or disconnecting cables at the drive or at the motor.

Failure to observe these safety procedures could result in personal injury or damage to the motor and equipment.



ATTENTION: The maximum length of cabling between the drive and the motor must not exceed 90 m (295.5 ft). Also, a maximum of two extension cables may be connected from a motor to a drive.



ATTENTION: To avoid the hazard of electrical shock, ensure shielded power cables are grounded at a minimum of one point. To prevent the build-up of electrical energy, factory-supplied power cables use one of these grounding techniques:

- Bond the overall shield to the connector housing.
- Connect an exposed section of the overall shield to ground.
- Connect an exposed cable braid or a ground wire, if present, to the power cable clamp, housing, or another suitable chassis ground on the drive.

Failure to observe these safety procedures could result in personal injury or equipment damage.



ATTENTION: Do not tightly gather or coil the excess length of a power cable. Heat is generated within a cable whenever power is applied. Always position a power cable so it may freely dissipate any heat.

A power cable should not be coiled, except for temporary use when building or testing a machine. If you temporarily coil a power cable, you must also derate the cable to meet local code or follow an authoritative directive, such as Engineering Section 310.15(C) of the NEC Handbook.

Failure to observe these safety procedures could result in personal injury or equipment damage.



ATTENTION: The examples in this publication show the available connections, some of which may not be appropriate for your specific installation. Refer to your drive installation instructions or user manual for recommended wire trim lengths, and wiring examples appropriate to your drive and motor application.

Do not connect unused wires. Unused wires may be trimmed and finished as necessary to prevent accidental contact with other wires or wire shields, or with a ground connection.

Failure to observe these safety procedures could result in personal injury or damage to the motor and equipment.

Install Cables

Follow these steps when installing a cable.

1. Provide the recommended installation areas, and the correct offset from features, before beginning any cable bend.

Features include these areas on the cable:

- Connectors
- Transitions from exposed wire to insulation (for example, flying leads)
- Exposed cable ground shields

The offset from these areas should be greater than or equal to ($\geq 1x$) the cable diameter.

2. Keep cable bends within the bend radius listed in the [Specifications on page 7](#).

General guidelines for the bend radius of a cable are listed below, however, individual cables may have additional restrictions:

- Standard cables have a static or one-time bend radius of 10 times ($\leq 10x$) the cable diameter.
- Continuous-flex cables have an operational bend radius of 12 times ($\leq 12x$) the cable diameter.

3. Observe these restrictions on the flex zone and installation areas when installing the cable:
 - The flex zone is the area in which the cable can repeatedly flex up to its specified bend radius.
 - Installation areas require rigid mounting to prevent the cable from flexing where it connects to other components.

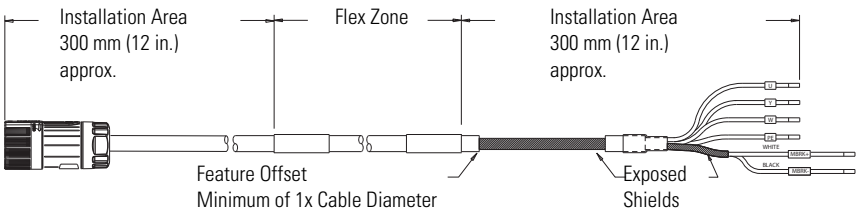

2090-CPBM7DF-xxAFxx Shown

4. Identify each connection on a cable by attaching a label around the outer insulation of each wire adjacent to the drive connection.
5. Remove the O-ring on the motor receptacle when using a cable with a SpeedTec plug.
The type of plug on the cable determines whether an O-ring is required on the receptacle.

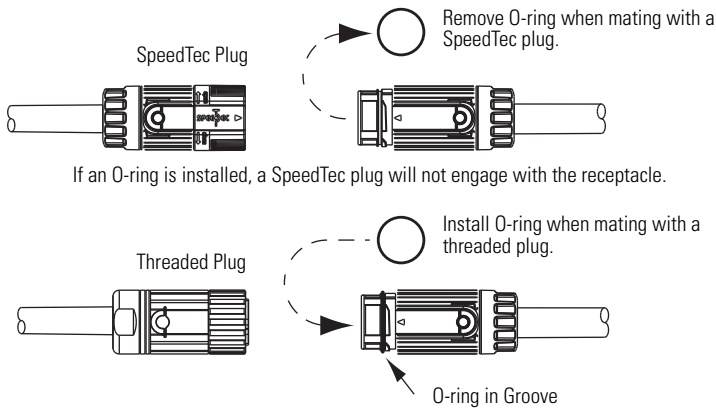

IMPORTANT The O-ring dampens the effects of vibration at the cable-to-motor connection. This creates a more secure connection for a cable with a threaded plug.

Schematics and Connector Pinouts for Cables

Wire colors and connector pinouts necessary to connect the cable to a servo system are shown in the schematics.

2090-CPBM7DF-xxAFxx Cables

This cable is available in several wire gauges and lengths. Refer to the Kinetix Motion Control Selection Guide, publication [GMC-SG001](#), for this information and additional specifications.

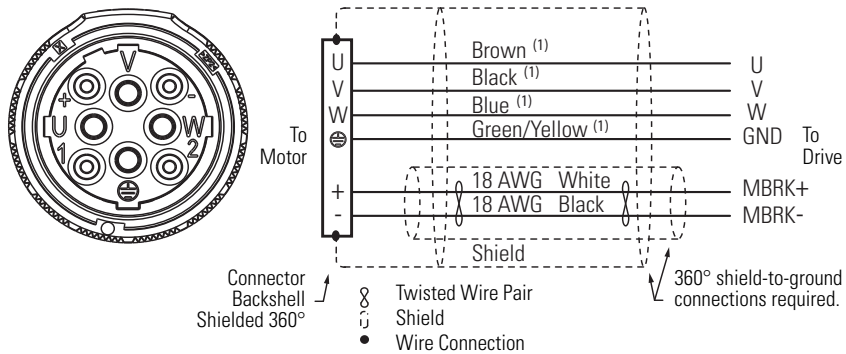

(1) Wire gauge and connector keying varies based on motor and power requirements. Refer to the Kinetix Motion Control Selection Guide, publication [GMC-SG001](#), for additional information.

2090-CPWM7DF-xxAFxx Cables

This cable is available in several wire gauges and lengths. Refer to the Kinetix Motion Control Selection Guide, publication [GMC-SG001](#), for this information and additional specifications.

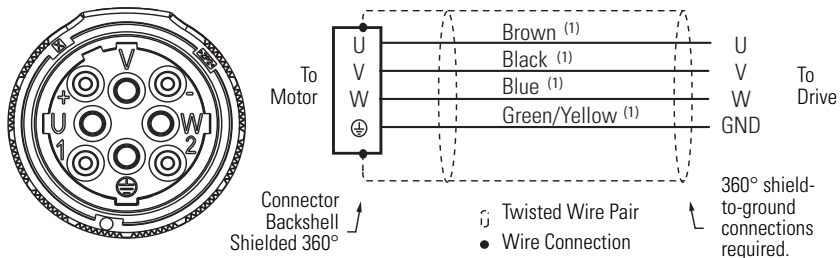

(1) Wire gauge and connector keying varies based on motor and power requirements. Refer to the Kinetix Motion Control Selection Guide, publication [GMC-SG001](#), for additional information.

Specifications

These specifications provide information that is useful when installing a cable. Additional specifications for each cable are available in the Kinetix Motion Control Selection Guide, publication [GMC-SG001](#).

2090-CPBM7DF-xxAFxx Cables

Attribute	2090-CPBM7DF-10AFxx	2090-CPBM7DF-08AFxx
Wire size	10 AWG	8 AWG
Diameter	17.8 mm (0.7 in.)	20.5 mm (0.81 in.)
Bend radius ⁽¹⁾		
Flex area	214 mm (8.5 in.)	250 mm (10 in.)
Installation areas ⁽²⁾	178 mm (7.0 in.)	205 mm (8.1 in.)

(1) Apply the bend radius multiplier for operational (12 x dia.) and static (10 x dia.) bend radius to cables with a different diameter. Refer to the diagram to locate the areas for flex (operational) and static (installation) bend areas.

(2) The installation areas are approximately 300 mm (12 in.) in length at both ends of the cable. Secure this area with a rigid mount that prevents the cable from flexing where it connects to other components.

2090-CPWM7DF-xxAFxx Cables

Attribute	2090-CPWM7DF-10AFxx	2090-CPWM7DF-08AFxx
Wire size	10 AWG	8 AWG
Diameter	15.7 mm (0.6 in.)	20.3 mm (0.80 in.)
Bend radius ⁽¹⁾		
Flex area	200 mm (7.5 in.)	250 mm (10 in.)
Installation areas ⁽²⁾	157 mm (6.0 in.)	200 mm (8 in.)

(1) Apply the bend radius multiplier for operational (12 x dia.) and static (10 x dia.) bend radius to cables with a different diameter. Refer to the diagram to locate the areas for flex (operational) and static (installation) bend areas.

(2) The installation areas are approximately 300 mm (12 in.) in length at both ends of the cable. Secure this area with a rigid mount that prevents the cable from flexing where it connects to other components.

Additional Resources

These documents contain additional information concerning related Rockwell Automation products.

Resource	Description
Kinetix 300 EtherNet/IP Indexing Servo Drives User Manual, publication 2097-UM001	How to install, set up, and troubleshoot a servo-drive system.
Kinetix 2000 Multi-axis Servo Drive User Manual, publication 2093-UM001	
Kinetix 6000 Multi-axis Servo Drives User Manual, publication 2094-UM001	
Kinetix 6200 and Kinetix 6500 Modular Multi-axis Servo Drives User Manual, publication 2094-UM002	
Kinetix 7000 High Power Servo Drive User Manual, publication 2099-UM001	
Ultra3000 Digital Servo Drive Installation Manual, publication 2098-IN003 or Integration Manual, publication 2098-IN005	
Ultra5000 Intelligent Positioning Drives Installation Manual, publication 2098-IN001	
Allen-Bradley Industrial Automation Glossary, publication AG-7.1	A glossary of industrial automation terms and abbreviations.
System Design for Control of Electrical Noise Reference Manual, publication GMC-RM001	Information, examples, and techniques designed to minimize system failures caused by electrical noise.
Kinetix Motion Control Selection Guide, publication GMC-SG001	Specifications, motor/servo-drive system combinations, and accessories for Kinetix motion control products.
Rockwell Automation Product Certification website http://www.rockwellautomation.com/products/certification/	Declarations of Conformity (DOC) for Rockwell Automation products.

You can view or download publications at <http://www.rockwellautomation.com/literature>. To order paper copies of technical documentation, contact your local Rockwell Automation distributor or sales representative.

Allen-Bradley, Kinetix, MP-Series, Rockwell Automation, Rockwell Software, Ultra3000, and Ultra5000 are trademarks of Rockwell Automation, Inc.

Trademarks not belonging to Rockwell Automation are property of their respective companies.

Rockwell Otomasyon Ticaret A.Ş., Kar Plaza İş Merkezi E Blok Kat:6 34752 İçerenköy, İstanbul, Tel: +90 (216) 5698400

www.rockwellautomation.com

Power, Control and Information Solutions Headquarters

Americas: Rockwell Automation, 1201 South Second Street, Milwaukee, WI 53204-2496 USA, Tel: (1) 414.382.2000, Fax: (1) 414.382.4444
Europe/Middle East/Africa: Rockwell Automation NV, Pegasus Park, De Kleetlaan 12a, 1831 Diegem, Belgium, Tel: (32) 2 663 0600, Fax: (32) 2 663 0640
Asia Pacific: Rockwell Automation, Level 14, Core F, Cyberport 3, 100 Cyberport Road, Hong Kong, Tel: (852) 2887 4788, Fax: (852) 2508 1846

Publication 2090-IN026B-EN-P January 2011

PN-95575

Supersedes Publication 2090-IN026A-EN-P July 2009

Copyright © 2011 Rockwell Automation, Inc. All rights reserved. Printed in the U.S.A.