

Installation Instructions

45CLR ColorSight™

(3 Output Channel Color Sensor)

IMPORTANT: SAVE THESE INSTRUCTIONS FOR FUTURE USE.

Description

The ColorSight™ 45CLR is a self-contained color detection sensor with three PNP output channels. This sensor utilizes a single white LED light source with three available spot size models for full color spectrum detection and maximum application flexibility.

The 45CLR ColorSight can be set up to detect:

- A single color per channel with adjustable tolerance
- Scan an area of various colors on the same surface
- Detect multiple individual colors per channel

Features

- Wide sensing range tolerance
- Three channel color matching (three outputs)
- Gating input (Also known as inhibiting input)
- Adjustable tolerance for high precision to general color matching
- Optional pulse stretching (50 ms)
- Teach colors via pushbuttons
- External teach capability
- Teach button lockout
- 270° rotatable connector
- IP 67 enclosure

Approximate Dimensions [mm (inches)]

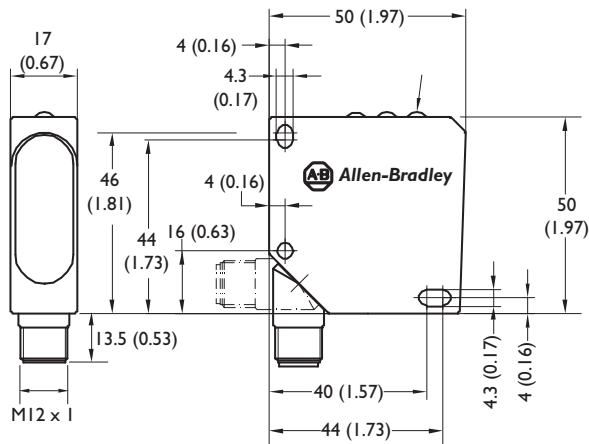

General Specifications

Certifications	cULus and CE marked for all applicable directives
Light Source	White LED
Sensing Range [mm (in.)]	45CLR-5JPC1-D8: 12...32 (0.47...1.26) 45CLR-5JPC2-D8: 15...30 (0.59...1.18) 45CLR-5JPC3-D8: 18...22 (0.70...0.86)
Sensing Range Tolerance	45CLR-5JPC1-D8: ± 6 mm 45CLR-5JPC2-D8: ± 5 mm 45CLR-5JPC3-D8: ± 2 mm
Spot Size [mm (in.)]	45CLR-5JPC1-D8: 4 (0.15) round @ 22 (0.86) 45CLR-5JPC2-D8: 2 x 2 (0.07 x 0.07) @ 22 (0.86) 45CLR-5JPC3-D8: 5 x 1 (0.19) @ 22 (0.86)
Supply Voltage	18...28V DC
Current Consumption	≤40 mA @ 24V DC
Protection Type	Short circuit, overload, false pulse, transient noise, reverse polarity
Output Type	Discrete: 3 PNP outputs (N.O.)
Output Rating	100 mA max per channel output
Response Time	Output: Normal Teach mode (CH1,CH2,CH3): 1 mS External Teach mode (CH3): 2 mS
Housing Material	Plastic ABS
Lens Material	PMMA
Connection Type	8-Pin DC Micro, 270° Rotatable
Accessory	Cordsets, Mounting Brackets
Enclosure Type Rating	IP67
Vibration	10...55 Hz, 1.5 mm amplitude; 3 planes; meets or exceeds IEC 60947-5-2
Shock	30 g; 11 ms; meets or exceeds 60947-5-2
Operating Temperature—C (F)	-10...+55° (14...131°)

Pinout and Color Codes

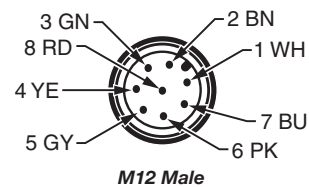

Pin	Color	Connection
1	White	Gate Input
2	Brown	V+ 12...28V DC
3	Green	OUT 1
4	Yellow	OUT 2/Teach Confirmation
5	Grey	Teach Button Lock
6	Pink	OUT 3/Remote Teach
7	Blue	V- 0V DC
8	Red	Not Connected

Wiring Diagrams

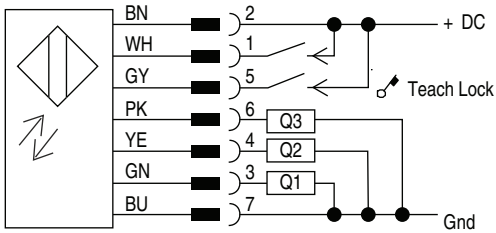

Remote Teach

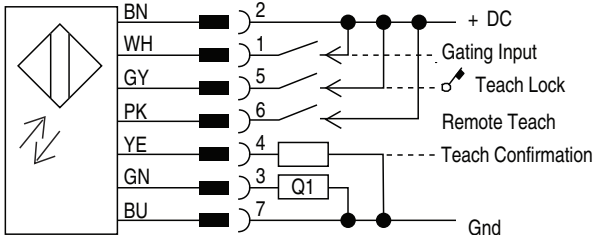

The control input (pin 5) can be used to lock the ColorSight pushbuttons by connecting it to the +DC (18...28V DC). When working with the sensor in remote teach, we recommend the use of pushbutton lockout to prevent accidental tampering of the configuration.

Percentage of Color Detection vs. Sensing Range

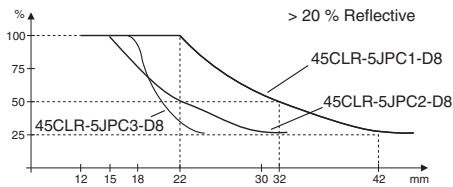

Sensor Alignment

Position the 45CLR sensor so that the distance from the object to the sensor will be within the sensing range. Extremely shiny or reflective surfaces can distort the color detection. This sensor should be mounted at an angle of 10...30°, as shown below.

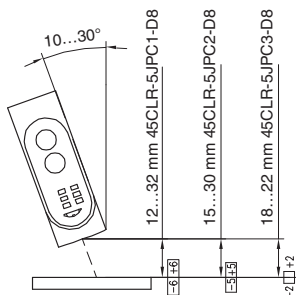

Mounting

Securely mount the sensor on a firm, stable surface or support for reliable operation. The following mounting brackets are available for installation convenience and sensor protection. Once securely mounted, the sensor can be wired per the attached wiring diagrams.

45BPD-BKT1 Approximate Dimensions—mm (in)

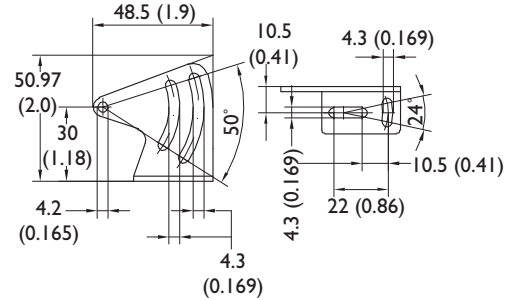

45BPD-BKT2 (Protective Bracket) Approximate Dimensions—mm (in)

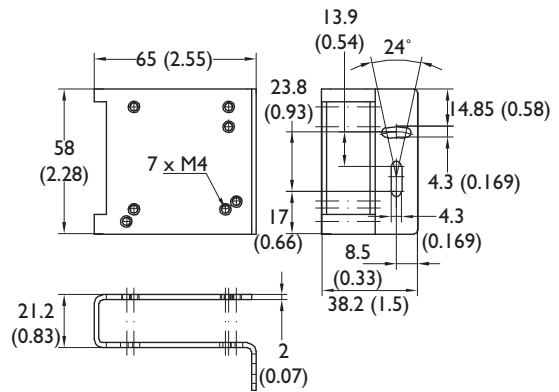

Teach Interface

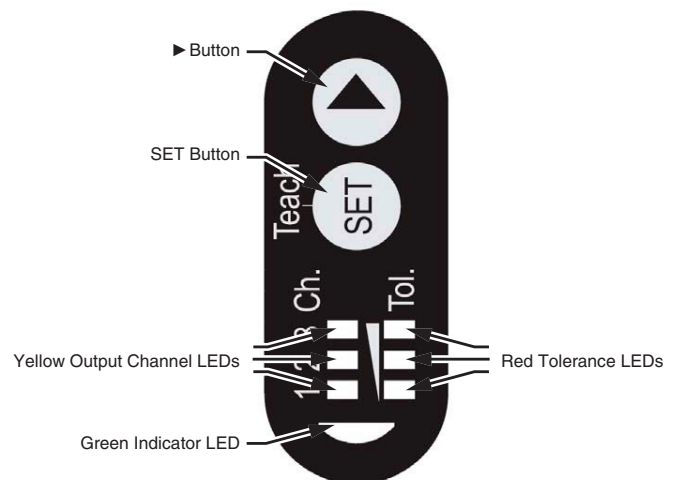

Gating Input

The Gating Input can be used to inhibit the operation and output of the 45CLR. This allows the user to only operate the 45CLR when another sensor detects that the object is present. For example, the "gating" sensor detects when a bottle is present, and only at that time the 45CLR detects the color of the cap.

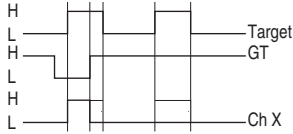

Gating Input: High (+DC)
(Outputs inactive, light source off)
Low (0V) or float/not connected
(Sensor active)

Tolerance Levels

After an object has been taught, move the object manually within the sensing range or positions that can occur in your application. Check that the programmed channel is effectively detecting the color. If the color is not being detected reliably adjust the tolerance one level higher. By repeating this procedure, the optimal tolerance level can be determined.

Adjusting the tolerance levels on the 45CLR enables the user to define the amount of variation in color that the sensor will detect. For example, a tight tolerance will only detect the specific color taught to the sensor while a wide tolerance can detect slightly lighter or darker shades of the color. Up to five tolerance levels can be selected as shown on the chart below.

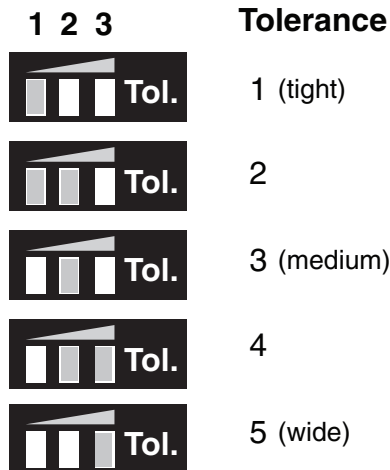

45CLR ColorSight Setup

The 45CLR ColorSight is set up using the pushbuttons (SET and ►) and the LED indicators on the top of the sensor. There are three available ways to set up the sensor:

Simple Teach

To teach the 45CLR ColorSight to detect a single color using one channel:

1. Place the color target within the sensing range.
2. Enter teach mode by pressing SET for three seconds until the green LED turns off and the yellow channel one LED turns on. Note that the white light turns off when you enter teach mode.
3. Push SET for three seconds until the tolerance LED (red) turns on. Press ► to adjust tolerance to the desired level. When changing the tolerance levels, the green LED works as a guide indicating if the color tolerance is too low for detection as described in the Tolerance Levels section above.
4. Push for three seconds to confirm the desired tolerance level.
5. The sensor is now ready to operate (yellow channel one LED is on when the target is present). White LED detection beam is also on during normal operation.

Normal Teach

To teach the sensor to learn multiple colors using multiple channels:

1. Place the color target within the sensing range.
2. Enter teach mode by pressing SET for three seconds until the green LED turns off and the yellow channel one LED turns on.
3. Select the desired channel to teach using the ► button. To confirm the color to be taught for a selected channel Press SET for three seconds until the red tolerance LED turns on.
4. Select desired tolerance level. When changing the tolerance levels, the green LED works a guide indicating if the color tolerance is too low for detection.
5. Press SET for three seconds until the red tolerance LED turns off to exit teach mode.

Repeat instructions to teach additional channels.

Advanced Teach (Color Scan)

The Color Scan feature enables you to teach and detect objects with various colors and individual multiple colors to each channel.

1. Place the object with various colors within sensing range.
2. Enter teach mode by pressing SET for three seconds until the green LED turns off and the channel one yellow LED turns on. Note that the white LED light spot is also turns off.
3. Select the channel you want to teach using the ► button.
4. Press and hold SET until the green LED is blinking. Continue to hold SET while moving the object to scan all colors by the sensor's white light spot. When you are finished scanning the object, release the SET button.
5. The sensor is now ready to operate. (Confirm that the scanned objects turn the channel yellow LED on.)

To teach multiple individual colors per channel

The Color Scan feature can be used to teach multiple individual colors per channel using the same procedure as above. In step 4, present individual colors in a sequential (without any disruptions) manner.

Repeat instructions to teach additional output channels.

Special Functions

Remote Teach

1. Enter teach mode by pressing SET for three seconds until the green LED turns off and the yellow channel one LED turns on.
2. Press ► until all three yellow channel (CH1, CH2, CH3) LEDs turn on.
3. Press SET for three seconds to confirm.
4. Press ► until the middle red tolerance LED is on.



5. Press SET for three seconds to confirm.
6. Press ► until all the red (tolerance) LEDs turn off.
7. Press SET for three seconds.
8. The sensor is now in Remote Teach mode. When entering remote teach mode the output Q3 becomes a teach input. Connect this pin to +V/+DC to teach a new color with medium tolerance on channel one. In Remote Teach mode, output Q2 is a teach acknowledgment. When the sensor is successfully taught a color, output Q2 will turn on for 50 mS to confirm a successful teach.

Pulse Stretching

1. Enter teach mode by pressing SET for three seconds until the green LED turns off and the channel one yellow LED turns on.
2. Press ► until all three yellow channel (CH1, CH2, CH3) LEDs turn on.
3. Press SET for three seconds to confirm.
4. Press ► until the red low tolerance LED turns on.



5. Press SET for three seconds to confirm.
6. Press ► until all the red (tolerance) LEDs turn off.
7. Press SET for three seconds.
8. The sensor is now ready to operate. (Yellow channel LED is on when target is present.) A color match on any channel will result in an output signal at least 50 mS in length.

Default Factory Settings

To configure the sensor to the manufacturer's default settings:

1. Enter teach mode by pressing SET for three seconds until the green LED turns off and the channel one yellow LED turns on.
2. Press ► until all three yellow channel (CH1, CH2, CH3) LEDs turn on.
3. Press SET for three seconds to confirm.
4. Press ► until the (CH1 & CH2) red tolerance LED turns on.



5. Press SET for three seconds to confirm until the green power LED turns on.
6. Press ► until all the red (tolerance) LEDs turn off.



7. Press SET for three seconds until the green power LED turns on. The sensor has now been set to manufacturer's default settings. All special functions are de-activated and previous color settings are reset.

Cordsets and Accessories

Description	Cat. No.
DC Micro Style QD Cordset, 8-Pin	889D-F8AB-2
Mounting Bracket. Used for Laser Sensors 45CPD, 45BRD	45BPD-BKT1
Protective Mounting Bracket. Used for Laser Sensors 45CPD, 45BRD	45BPD-BKT2