

LISTEN.
THINK.
SOLVE.®

Solid-State Flow Sensors



USER MANUAL

839E

Important User Information





Because of the variety of uses for the products described in this publication, those responsible for the application and use of this control equipment must satisfy themselves that all necessary steps have been taken to assure that each application and use meets all performance and safety requirements, including any applicable laws, regulations, codes and standards.

The illustrations, charts, sample programs and layout examples shown in the guide are intended solely for purposes of example. Since there are many variables and requirements associated with any particular installation, Rockwell Automation does not assume responsibility or liability (to include intellectual property liability) for actual use based upon the examples shown in this publication.

Rockwell Automation publication SGI-1.1, Safety Guidelines for the Application, Installation and Maintenance of Solid-State Control (available from your local Rockwell Automation sales office), describes some important differences between solid-state equipment and electromechanical devices that should be taken into consideration when applying products such as those described in this publication.

Reproduction of the contents of this copyrighted publication, in whole or part, without written permission of Rockwell Automation, is prohibited.

Throughout this manual we use notes to make you aware of safety considerations:

WARNING 	Identifies information about practices or circumstances that can cause an explosion in a hazardous environment, which may lead to personal injury or death, property damage, or economic loss.
IMPORTANT	Identifies information that is critical for successful application and understanding of the product.
ATTENTION 	Identifies information about practices or circumstances that can lead to personal injury or death, property damage, or economic loss. Attentions help you identify a hazard, avoid a hazard, and recognize the consequences.
SHOCK HAZARD 	Labels may be on or inside the equipment (for example, drive or motor) to alert people that dangerous voltage may be present.
BURN HAZARD 	Labels may be on or inside the equipment (for example, drive or motor) to alert people that surfaces may reach dangerous temperatures.

It is recommended that you save this user manual for future use.

Table of contents

Safety instructions	2
Designated use.....	2
Installation, commissioning and operation	2
Operational safety.....	2
Return	2
Product identification	3
Installation	4
Dimensions	4
Process connection.....	5
Installation instructions.....	6
Wiring	8
Operation	10
On-site programming	10
Programming with personal computer and ReadWin 2000	19
Accessories	21
Configuration kit with ReadWin.....	21
Troubleshooting	22
Error and warning codes.....	22
Repair.....	23
Disposal.....	23
Change status (release).....	23
Technical data	24
Power supply.....	24
Output.....	24
Operating conditions.....	25

Safety instructions

Designated use

The Bulletin 839E is a flow switch for measurement and monitoring of mass flow rates in industrial processes. The device has been safely built with state-of-the-art technology and meets the applicable requirements and EC Directives. It can, however, be a source of danger if used incorrectly or for anything other than the designated use.

Installation, commissioning and operation

Only personnel familiar with these types of products and associated machinery should plan or implement the installation, start-up, configuration, and subsequent maintenance of the Bulletin 839E flow switch. Failure to comply may result in personal injury and/or equipment damage.

Operational safety

- Functional Safety
The 839E flow switch was developed according to standard IEC 61010.
- Ex-area
The 839E is not approved for use in Ex-areas.

Return

Before returning a device to Rockwell Automation, be sure to remove all fluid residue. This is particularly important if the fluid is a health hazard, e.g. flammable, toxic, caustic, carcinogenic, etc.

ATTENTION



Do not return a measuring device if you are not absolutely certain that all traces of hazardous substances have been removed, e.g. substances which have penetrated crevices or diffused through plastic.

Product identification

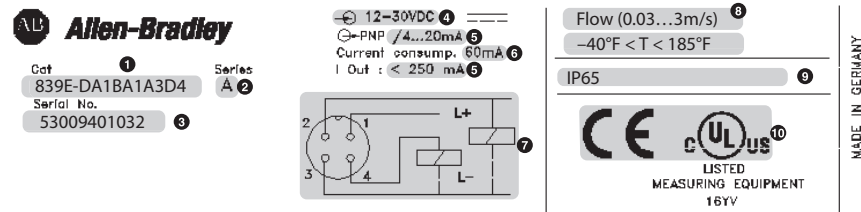

Figure 1 Explanation of the nameplate — see Table below

1	Catalog number	6	Current consumption
2	Series letter	7	Wiring diagram
3	Serial number	8	Flow rate and ambient temperature range
4	Operating voltage	9	Enclosure rating/ingress protection
5	Output	10	Approvals

Notes:

- Specifications and ratings may differ from those shown in Figure 1, depending on particular model. Refer to product nameplate or catalog for actual ratings and specifications.
- The series number indicates the version of the switch. A change in the series letter does not have any effect on the compatibility—see “Change status” section.
- Approvals include 3A authorized for models configured with sanitary adaptors.

Installation

Dimensions

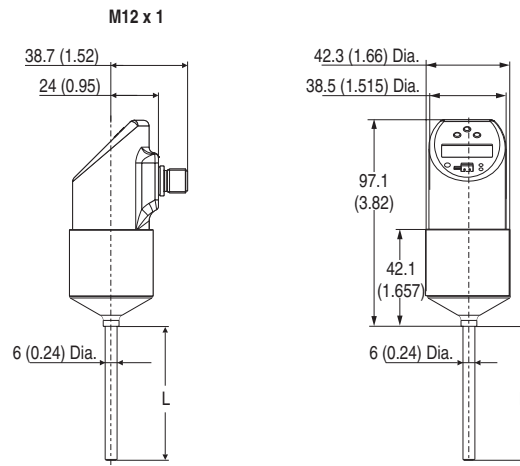
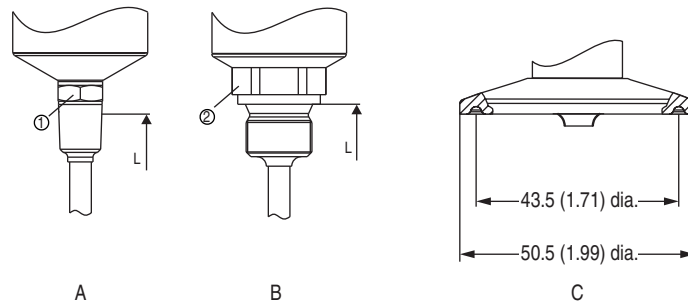

Figure 2 Dimensions [mm (in.)]

Version L with 30 and 100 mm (1.18 and 3.94 in.)
M 12x1 connector as per IEC 60947-5-2

Process connection

The following table illustrates the versions of 839E.



Field of application	Measuring and monitoring of mass flow rates		Measurement and monitoring, mass flow rates in sanitary processes
Process connection	Item A Version with thread process connection ANSI ¼-in. NPT (1 = AF14) and ½-in. NPT (1 = AF27)	Item B Version with thread process connection G ¼ (2 = AF14) and G ½ (2 = AF27) as per ISO 228	Item C Version with 50.8 mm (2 in.) clamp or 25.4...38.1 mm (1...1.5 in.)
Thread Length L1	14.3 mm (0.56 in.) 19 mm (0.75 in.)	12 mm (0.47 in.) 14 mm (0.55 in.)	—
Thread Length L2	5.8 mm (0.23 in.) 8.1 mm (0.32 in.)	—	—
Sensor length L	Version L with 30 and 100 mm (1.18 and 3.94 in.)		
Operational range	Liquids from 0.03 to 3.0 m/s (0.1 to 9.84 ft/s)		

Installation instructions

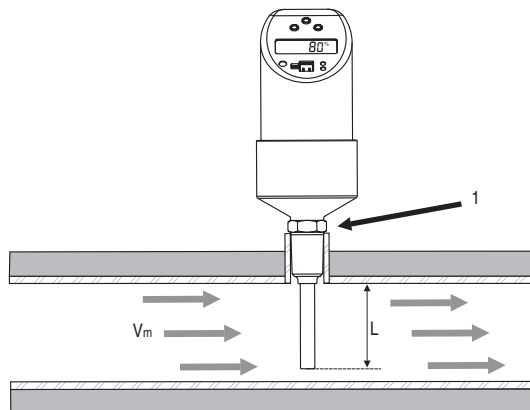

Figure 3 Installing Bulletin 839E (example). Sensor length L is completely immersed in the flow profile.

Mounting instructions:

- Any orientation
- The on-site display can be rotated electronically 180° — see “Operation” section.
- The housing can be rotated up to 310° for optimal readability and ease of wiring.
- Minimum sensor immersion length: $L \geq 10$ mm (0.4 in.)
- The sensor tip should not touch the pipe wall.
- If used in a vertical pipe, the flow should be ascending.
- For a horizontal pipe, install sensor from top if pipe is completely filled with medium. Otherwise, install sensor from side to ensure complete length of sensor is in the medium.

ATTENTION



Do not turn the device into the process connection thread at the housing. Always install the device at the hexagonal-head bolt (refer to Figure 3, detail 1). Use a suitable open-ended wrench for this task.

Note!

For correct flow measurement, the complete length of the sensor must be immersed in the fully developed flow profile.

Installation instructions

Installation conditions

Note!

The sensor requires a fully developed flow profile for correct monitoring. For this reason, steadying sections (5x DN) must be provided in the pipe after a pump, pipe bend, internal fittings and cross-sectional changes.

ATTENTION



Do not turn the device into the process connection thread at the housing. Always install the device at the spanner flats (Figure 4, item 1). Use a suitable open-ended wrench for this task (see table of page 5).

- The onsite display can be rotated electronically 180°, see “Onsite operation” section.
- The upper housing section can be rotated mechanically up to 310°.

Wiring

- The sensor tip should be completely surrounded by medium.
- Position the sensor tip in the area of maximum fluid velocity (pipe center).
- Minimum sensor immersion length: $L_1 \pm 10$ mm.

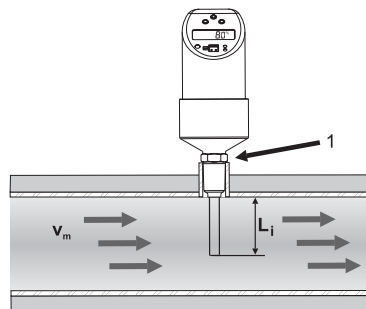

Figure 4 Installation conditions

Orientation:

- For horizontal pipes: lateral installation.

Note!

Installation from above (see Figure 4) only if the pipe is completely filled with medium during operation.

- For vertical pipes: installation in the ascending pipeline.
- Installation of 839E by min. 3° inclination, because of self draining.

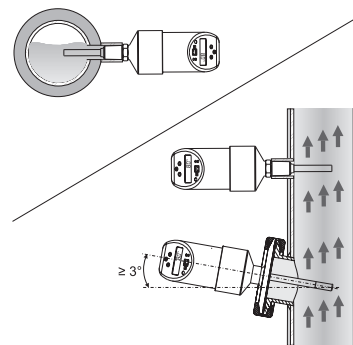

Figure 5 Correct orientation

ATTENTION



- Do not install in down pipes open towards the end.
- The sensor tip should never touch the pipe wall.

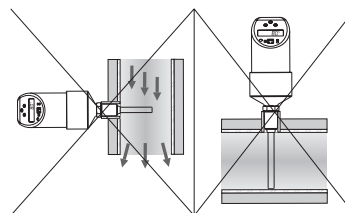

Figure 6 Incorrect installation

DC voltage version with M12 connector

Figure 7 DC voltage version with M12 connector

Bulletin 839E with M12x1 connector

A1: PNP switch outputs R1 and R2

A2: PNP switch output with 4...20 mA analog output

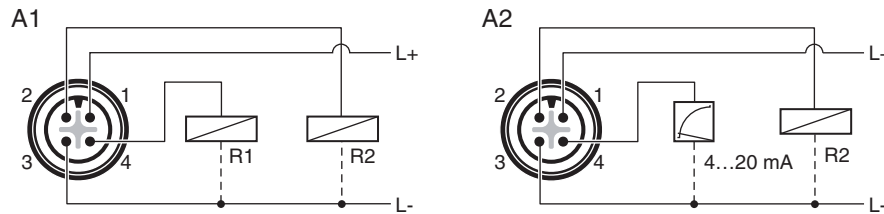
Mating cables

2 m (6.5 ft) PVC cable with 4-pin micro (M12x1) connector and ratcheted epoxy-coated zinc coupling nut.
Catalog number: 889D-F4AC-2

2 m (6.5 ft) PVC cable with 4-pin micro (M12x1) right-angle connector and ratcheted epoxy-coated zinc coupling nut.
Catalog number: 889D-R4AC-2

Note: Other cable lengths are available and shielded cables may be required for some analog output applications — refer to the On-Machine Connectivity catalog for additional information.

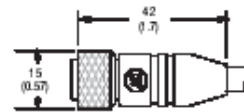

889D-F4AC-2

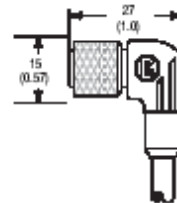

889D-R4AC-2

Operation

On-site programming

The Bulletin 839E is programmed via three push buttons. The digital display and the light emitting diodes (LEDs) assist in the navigation through the operating menu.

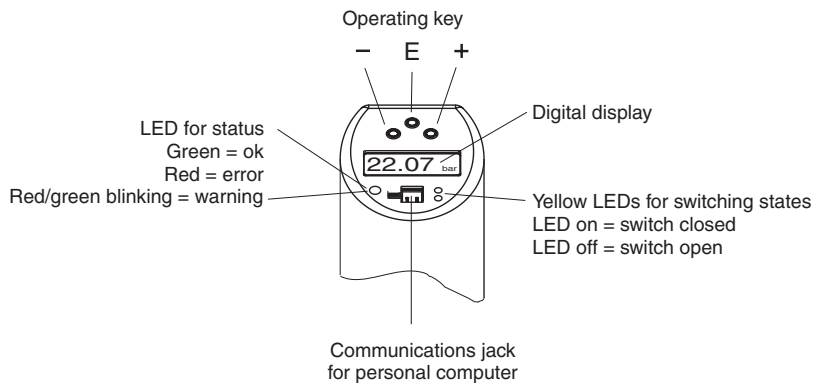

Figure 8 Location of operating keys and display elements

Background illumination of the digital display:

- White = OK status
- Red = alarm/error status

Navigating through the programming menu

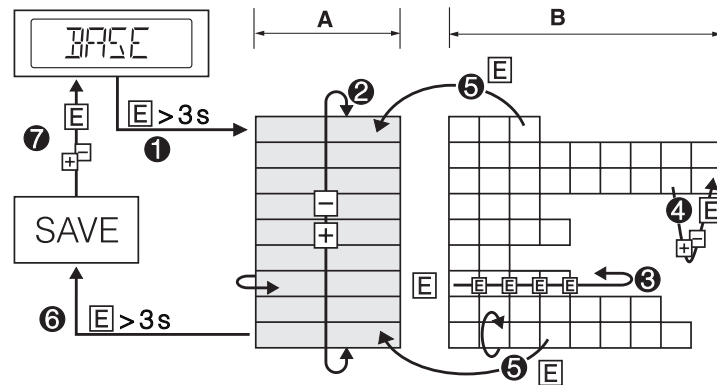

Figure 9 Navigating through the programming menu

A Function group selection

B Function selection

❶ Enter the programming menu:

- Press and hold the E key for longer than 3 sec.

❷ Once in programming mode (BASE will be displayed), toggle between the Function groups with the + and - keys

❸ To enter the Function group, press the E key

❹ Enter or change parameters with the + or - key.

- Then press the E key to return to the "Function" option

❺ Press the E key several times to return to the "Function group"

❻ Jump back to the measuring position (Home position)

- Then press the E key for longer than 3 sec.

❼ To save changes, choose YES or NO with the + or - key

- Confirm with the E key

ATTENTION



Changes take effect only when you choose YES when asked to save the data.

Navigating the “Learn” function

Figure 10 Navigating the “Learn” function using the Calibration (CAL) function group as an example

- ① Select the HIF (Learn High Flow) or LOWF (Learn Low Flow) function with the E key
- ② Select the “RUN” function with the + key, learn function is initialized
- ③ Select the “WAIT” function with the + key, press for longer than 2 sec.
- ④ Accept (“learn”) the current measured value after approx. 10 sec. - “OK” appears on the display
- ⑤ If “NOK” (not OK) appears on the display after 60 sec., no current measured value was set
- ⑥ Return to the CAL function group (Home position) with the E key

Notes!

1. Programming buttons [E], [-], and [+] may need to be pressed and held for several seconds before displaying the expected response.
2. When performing a calibration the 839E may require up to 60 seconds to learn the high or low flow rate. The display will indicate “WAIT” during the learn process.
3. After configuring the 839E to the desired settings, press and hold the [E] key until “SAVE” appears; press the [+] or [-] key until “YES” appears. Press and hold the [E] key until “SAVE” appears. Depending on the configuration changes the display may indicate a number or a blinking “INIT.” Wait for the blinking “INIT” to change to another value. This indicates the 839E is ready for operation.

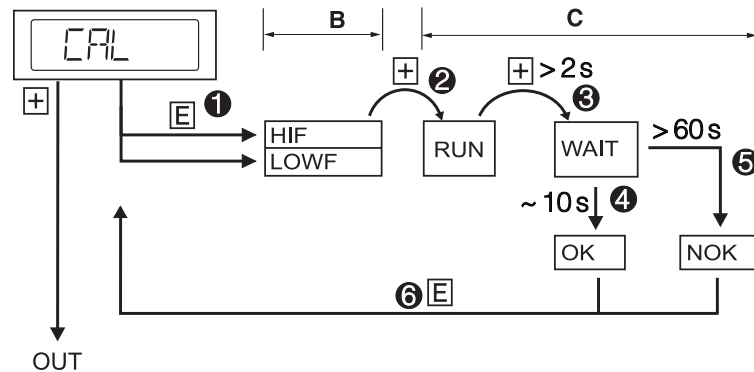
Structure of the operating menu

Structure of the operating menu for 1 x analog output (4...20 mA) and 1 x switch output (839E-DCxxxxxx).

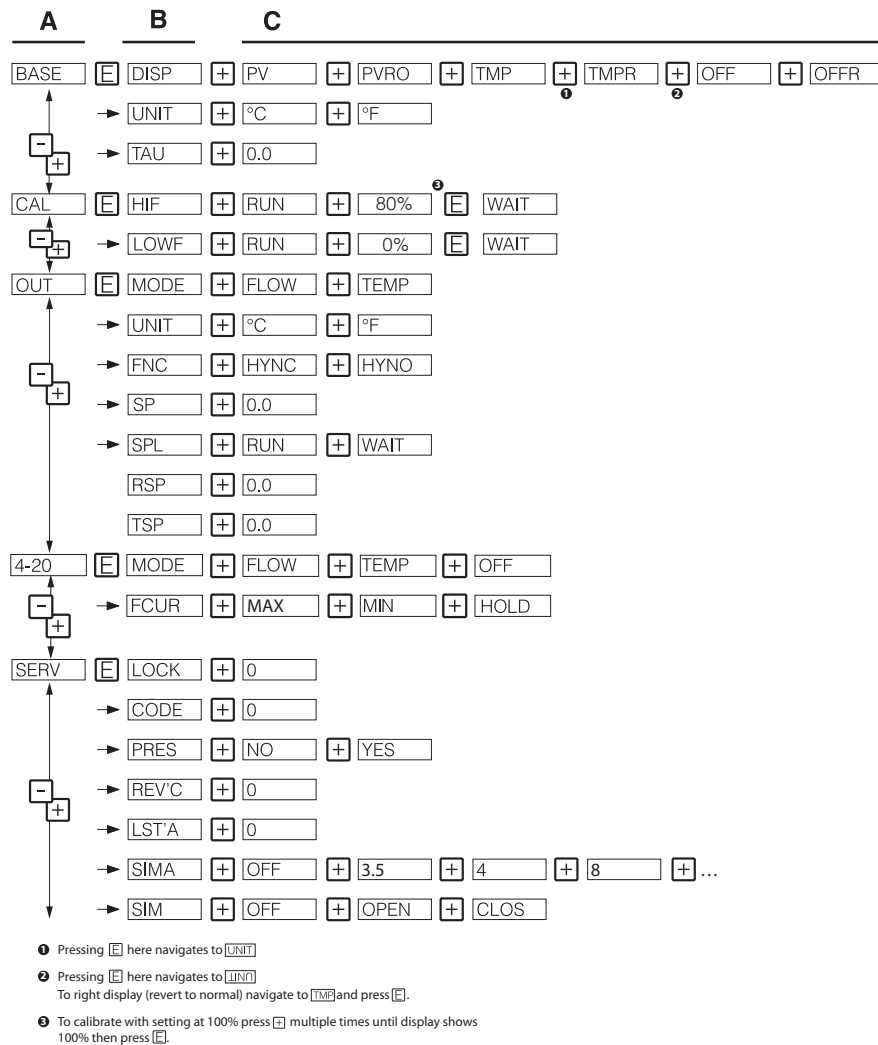

Figure 11 Operating menu: A function groups, B functions, C settings

Structure of the operating menu for two switch outputs (839E-DAxxxxxx)

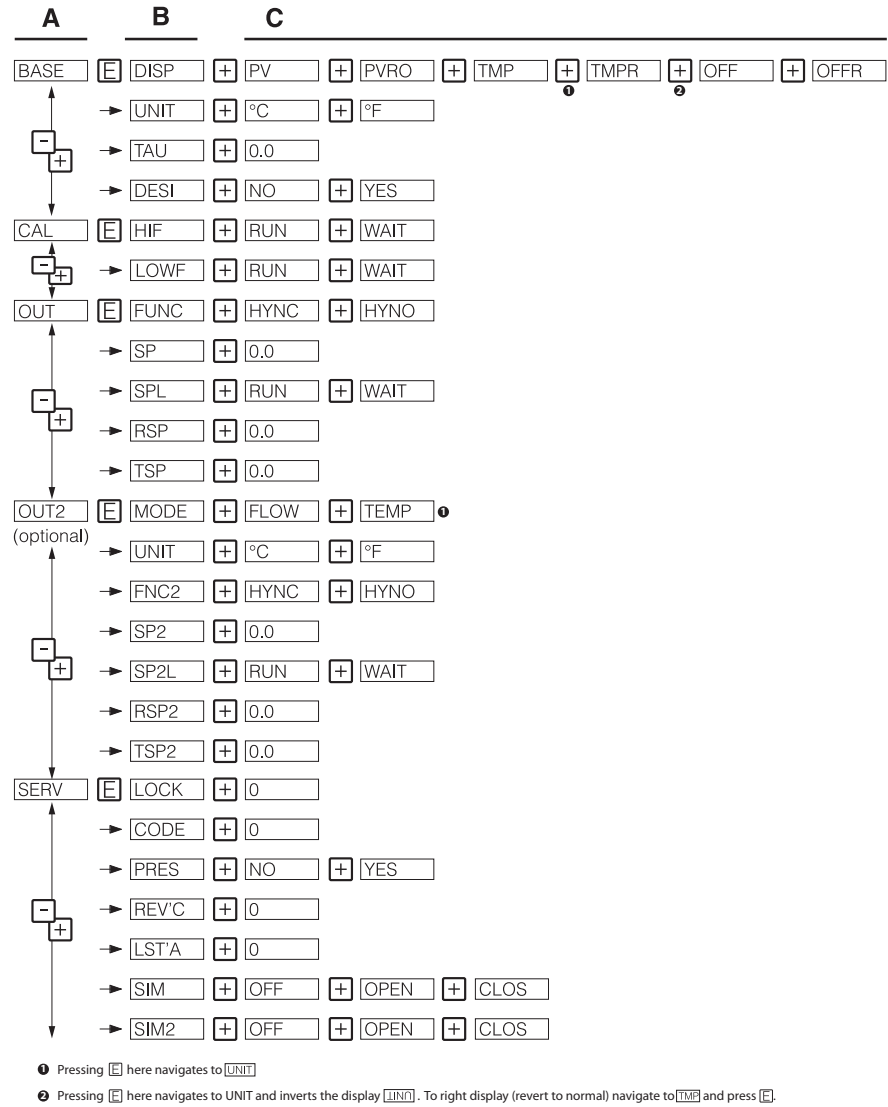

Figure 12 Operating menu: A function groups, B functions, C settings

Basic settings

Function group	Function (display)	Description
BASE (basic functions)	DISP	Display assignment: OFF Display of current measured value or of configured switch point (switch 1) Display of current measured value or of configured switch point (switch 1) rotated 180° Display of current medium temperature Display of current medium temperature rotated 180° Factory setting: current measured valued in %
	UNIT	Display medium temperature unit °C or °F Factory setting: °C NOTE: Only visible if the current medium temperature is selected in the DISP mode.
	TAU	Measured value damping with regard to display value and output: 0 (no damping) or 9...40 sec. (in increments of 1 second) Factory setting: 0 sec.
	DESI	Behavior as per DESINA: The PIN of the M12 connector is assigned in accordance with the guidelines of DESINA. (DESINA = DistributEd and Standardized INstAllation technology for machine tools and manufacturing systems)
CAL (Calibration)	HIF	Setting for maximum flow rate occurring. 100% value
	LOWF	Setting for minimum flow rate occurring. 0% value

Function group	Function (display)	Description
OUT (Setting for the 1st output) OUT2 (Setting for the 2nd output, optional)	MODE	Output switching mode for channel 2: flow or temperature Factory setting: flow
	UNIT	Temperature unit selection (°C/°F) NOTE: Function only visible if switching mode (MODE) is set to temperature in the 2nd output.
	FUNC	Switch output function: hysteresis function NC contact or NO contact (see diagram) 4...20 mA
	FNC2	
	SP	Enter value 5...100% in increments of 1%. Factory setting: 50% Or optionally for SP2: Enter value -15...85 °C (-5...185 °F) in increments of 1 °C (1 °F) if the switching mode (MODE) is set to temperature. Factory setting: 55 °C (131 °F)
	SP2	
	SP1	Take current flow rate as SP.
	SP2L	
	RSP	Enter value 0...95% in increments of 1%. Factory setting: 40% Note: The value has to be at least 5% smaller than the switch point (SP or SP2). Or optionally for RSP2: Enter value -20...80 °C (-4...176 °F) in increments of 1 °C (1 °F) if the switching mode (MODE) is set to temperature. Factory setting: 50 °C (122 °F) Note: The value has to be at least 5 °C (9 °F) smaller than the switch point 2 (SP2).
	RSP2	

Function group	Function (display)	Description
OUT and OUT2 (continued)	TSP	Can be set anywhere between 0...99 sec. in increments of 1 second. Factory setting: 0 sec.
	TSP2	
SERV (Service functions)	LOCK	Enter the device locking code.
	CODE	Locking, only visible with valid operating code.
	PRES	Resetting of all settings to factory settings.
	REVC	Configuration counter, increments each time the configuration is changed.
	STAT	
	LSTRA	Display of last error to occur.
	SIMU	Simulation switch output 1: on/off with display, optionally corresponding to switch output 2.
SIM2		

Functions of the switch point

- Hysteresis function

The hysteresis function enables two-point control via a hysteresis. Depending on the mass flow, the hysteresis can be set via the set point SP and the reset point RSP.

- N.O. contact or N.C. contact
This switch function is freely selectable.

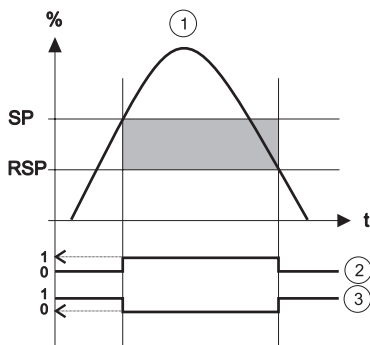

Figure 13 Hysteresis function, ② N.O. contact, ③ N.C. contact
SP = set point; RSP = reset point

Programming with personal computer and ReadWin 2000

The 839E can also be configured via personal computer and ReadWin software. An additional configuration kit with a conversion cable (Part number 836E-NSR) is required to interface the USB port of the PC to the programming port of the flow switch, as shown below.

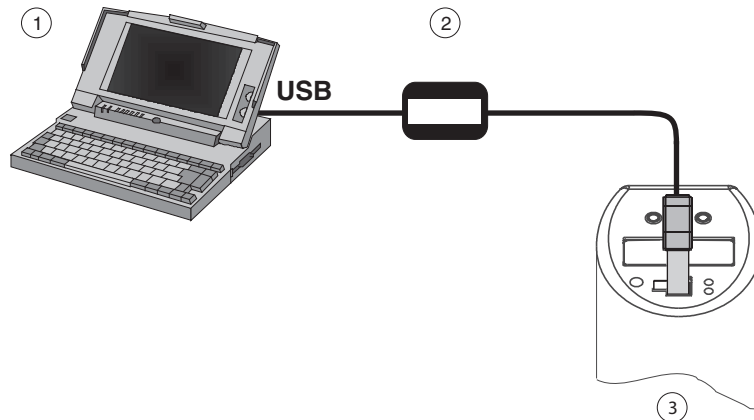

Figure 14 Programming with PC

- ① Personal computer with ReadWin configuration software
- ② Configuration kit (836E-NSR)
- ③ Bulletin 839E with programming port

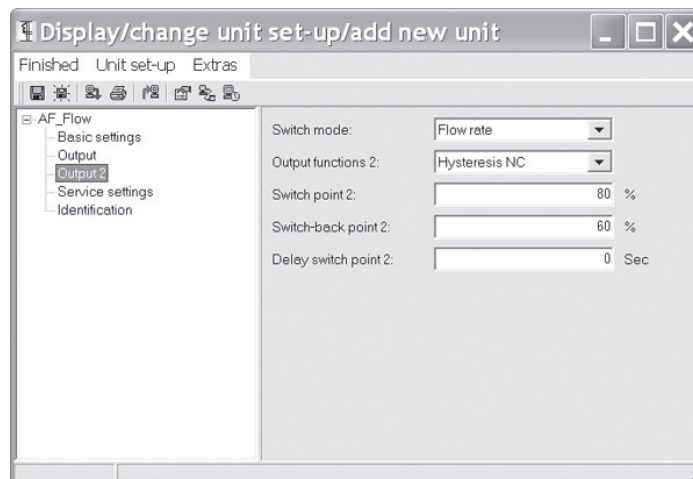

Figure 15 Sensor configuration with ReadWin

Additional operating options

In addition to the operating options listed in the "On-site programming" section, the ReadWin configuration software provides an additional function group with further information on the Bulletin 839E:

Function group	Function (display)	Description
SERV (service functions)	Switching processes 1 Switching processes 2, optional	Number of changes in switching status for switch output 1; optionally switch output 2
INFO (device information)	TAG 1 TAG 2, optional	Tagging, 18-digit
	Order code	Order code
	Serial number	Device serial number
	Sensor serial number	Sensor serial number
	Electronics serial number	Electronics serial number
	Device revision	Display of entire revision
	Hardware revision	Hardware version
	Software revision	Software version

Accessories

Configuration Kit with ReadWin

The configuration kit (Catalog Number: 836E-NSR) consists of a software CD and a conversion cable which interfaces the USB port of the PC to the 4-pin programming port on the sensor face.

ReadWin® 2000 software is also available free of charge via download from <http://ab.rockwellautomation.com>, select Product Directory/Sensors & Switches/Condition Sensors/Pressure Sensors/Solid-State Pressure Switches/Resources. Reference "Other Resources" and select "ReadWin Configurator for Windows™ 2000. zip.

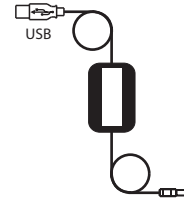
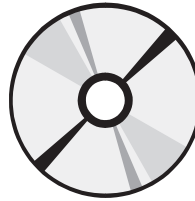

Troubleshooting

Error and warning codes

If an error occurs in the electronics, the color of the status LED changes from green to red and the background illumination of the digital display changes from white to red. A status LED flashing red and green displays an error or warning code, as outlined below:

- E-code for errors
In the event of an error message, the measured value is unreliable.
- W-code for warnings
In the event of a warning, the measured value is still reliable.

Error Codes

Code	Explanation
E011	Device configuration faulty
E012	Error in measurement or underrange/overrange
E013	Error at heating resistor
E015	Error in EEPROM
E019	Power supply has undervoltage/overvoltage
E020	Error in Flash
E021	Internal memory error
E022	USB power supply
E027	Characteristic does not suit medium
E042	Output current can no longer be generated. Possible cause: analog output not connected or open circuit.

Warning Codes

Code	Explanation
W107	Simulation active
W202	Flow outside the sensor range
W209	Device start-up
W210	Configuration modified
W212	Sensor signal outside the permitted range
W250	Number of switch cycles exceeded
W260	Value for High Flow (HIF) and Low Flow (LOWF) faulty
W270	Short-circuit and overload at output 1
W280	Short-circuit and overload at output 2
W432	Values for high flow (HIF) or low flow (LOWF) could not be determined with certainty. The device can be operated, however.

Repair

Bulletin 839E flow switches are not repairable.

Disposal

Please pay particular attention to the local disposal regulations of your country. Ensure the materials of the device components are separated and processed accordingly.

Change status (release)

The release number on the nameplate and in the Operating Instructions indicates the change status of the device: XX.YY.ZZ (example 01.02.01).

XX	Change in the main version. Compatibility no longer provided. Device and Operating Instructions change.
YY	Change in functionality and operation. Compatibility provided. Operating Instructions change.
ZZ	Troubleshooting and internal modifications. Operating Instructions do not change.

Technical data

Power supply

Supply voltage

- DC voltage version
18...30 V DC

Current consumption

- < 100 mA (open-circuit operation) at 24 V DC, max. 150 mA (open-circuit operation); with reverse polarity protection

Power supply failure

- Behavior in case of overvoltage (> 30V)

The device works continuously up to 34V DC without any damage. No damage is caused to the device in case of a short-term overvoltage up to 1 kV (as per EN 61000-4-5). If the supply voltage is exceeded, the properties specified are no longer guaranteed.

- Behavior in case of undervoltage

If the supply voltage drops below the minimum value, the device switches off (status as if not supplied with power = switch open).

Output

Switching capacity

- Switch status ON: $I_a \leq 250$ mA
- Switch status OFF: $I_a \leq 1$ mA
- Switching cycles: $\leq 10,000,000$
- Voltage drop PNP: ≤ 2 V
- Overload protection

Automatic load testing of switching current; output is switched off in case of overcurrent, the switching current is tested again every 0.5 sec.; max. capacitance load: 14 mF for max. supply voltage (without resistive load); periodical protective disconnection in event of overcurrent ($f = 2$ Hz) and 'Warning' display.

Signal on alarm

- Switch outputs: in safe state (switch normally open)

Operating conditions

- Any orientation
- Top housing section can be rotated 310°

Operating conditions: Environment

- Ambient temperature range
–40...+85 °C (–40...185 °F)
- Storage temperature
–40...+85 °C (–40...185 °F)
- Climate class
4K4H as per DIN EN 60721-3-4
- Degree of protection
IP65 complete housing
- Shock resistance
50 g as per DIN IEC 68-2-27 (11 ms)
- Vibration resistance
20 g as per DIN IEC 68-2-6 (10-2000Hz)
4 g as per guidelines of German Lloyd GL
- Electromagnetic compatibility
Interference emission as per IEC 61326, class B equipment
Interference immunity as per IEC 61326, Appendix A (industry) and
NAMUR Recommendation NE21; EMC influence: d 0.5%

Operating conditions: Process

- Process flow limits
Liquids: 0.03...3.0 m/s (0.1...9.84 ft/s)
- Process temperature limits
–20...85 °C (–4...185 °F)

Note!

The sensor can be exposed up to 130°C (266°F) without damage. Monitoring switches shut off automatically at $T \geq 85^\circ\text{C}$ (185°F) and starts again at $T \leq 85^\circ\text{C}$ (185°F).

- Process pressure limits
p/T load diagram as per DIN 43763 or Dittrich/Kohler (or as per ASME/ANSI PTC 19.3)

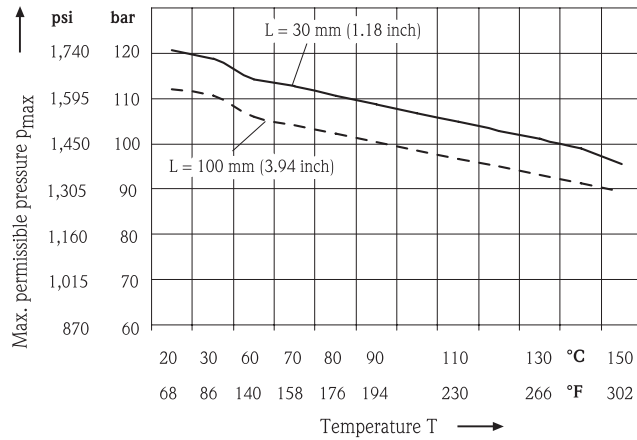

Figure 16 p/T load diagram

L = insertion length

vW = water fluid velocity = 3 m/s (9.84 ft/s)

Flow Switch Conversion

Feet per second (ft/s) to gallons per minute (gpm)

Flow ft/s	gpm									
	DN	1/2"	3/4"	1"	1 1/2"	2"	2 1/2"	3"	4"	
	id (inch)	0.37	0.62	0.87	1.37	1.87	2.37	2.87	3.87	
0.3	id (mm)	9.4	15.75	22.1	34.8	47.5	60.2	72.9	97.38	
0.7	0.1	0.3	0.6	1.5	2.8	4.5	6.6	11.8		
1.3	0.2	0.6	1.2	3.0	5.6	9.0	13.2	23.6		
2.0	0.4	1.2	2.4	6.0	11.2	18.0	26.5	47.2		
2.6	0.7	1.9	3.6	9.0	16.9	27.1	39.7	70.8		
3.3	0.9	2.5	4.9	12.1	22.5	36.1	52.9	94.4		
3.9	1.1	3.1	6.1	15.1	28.1	45.1	66.2	118.1		
4.6	1.3	3.7	7.3	18.1	33.7	54.1	79.4	141.7		
5.2	1.5	4.3	8.5	21.1	39.3	63.2	92.6	165.3		
5.9	1.8	4.9	9.7	24.1	44.9	72.2	105.9	188.9		
6.6	2.0	5.6	10.9	27.1	50.6	81.2	119.1	212.5		
7.2	2.2	6.2	12.2	30.2	56.2	90.2	132.3	236.1		
7.9	2.4	6.8	13.4	33.2	61.8	99.3	145.5	259.7		
8.5	2.6	7.4	14.6	36.2	67.4	108.3	158.8	283.3		
9.2	2.9	8.0	15.8	39.2	73.0	117.3	172.0	306.9		
9.8	3.1	8.6	17.0	42.2	78.6	126.3	185.2	330.5		
	3.3	9.3	18.2	45.2	84.3	135.3	198.5	354.2		

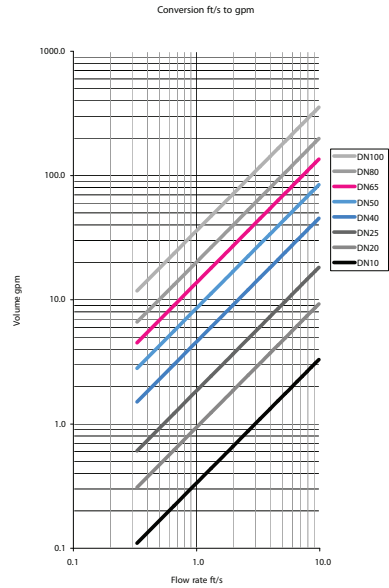

www.rockwellautomation.com

Power, Control and Information Solutions Headquarters

Americas: Rockwell Automation, 1201 South Second Street, Milwaukee, WI 53204-2496 USA, Tel: (1) 414.382.2000, Fax: (1) 414.382.4444
Europe/Middle East/Africa: Rockwell Automation NV, Pegasus Park, De Kleeflaan 12a, 1831 Diegem, Belgium, Tel: (32) 2 663 0600, Fax: (32) 2 663 0640
Asia Pacific: Rockwell Automation, Level 14, Core F, Cyberport 3, 100 Cyberport Road, Hong Kong, Tel: (852) 2887 4788, Fax: (852) 2508 1846

Publication 10000004735 Ver 03 — May 2012

© 2012 Rockwell Automation. Printed in the U.S.A.