



Inductive Proximity Sensors

Bulletin Numbers 802PR, 871C, 871D, 871F, 871FM, 871L, 871P, 871R, 871T, 871TM, 871TS, 871Z, 871ZC, 871ZT, 872C, 872L

Topic		Page
Tubular Sensors		
	871C Special Purpose	2
	871T Stainless Steel Barrel	12
	871TM All Stainless Steel	16
	871TS Food and Beverage	35
	871Z Weld Field Immune	36
	871ZT Weld Field Immune	39
	872C WorldProx™ General Purpose	41
Rectangular Sensors		
	802PR Limit Switch Style	72
	871F Block, Flat Pack, and Puck Style	80
	871FM Mini Flat Pack Style	90
	871L & 872L Limit Switch Style	94
	871P Can Sensors	98
	871P VersaCube Multi-position	101
Cylinder Sensors		
	871D Cylinder Positioning	106
	871D WorldClamp	108
Ring & Slot Sensors		
	871R Ring Style	110
	871S Slot Style	112



Tubular Sensors
871C 2-Wire AC Full Featured
 Plastic Face/Threaded Nickel-Plated Brass Barrel



871C AC Cable Style
18 & 30 mm



871C AC Mini
Quick-Disconnect Style
12, 18, and 30 mm



871C AC Micro
Quick-Disconnect Style
12, 18, and 30 mm

Specifications

	12 mm	18 & 30 mm
Load Current	5...200 mA	5...250 mA
Inrush Current (1 cycle)	≤2 A	≤4 A
Leakage Current	≤1.9 mA @ 120V AC	
Operating Voltage	20...250V AC	
Voltage Drop	≤10V @ 5...200 mA	≤10V @ 5...250 mA
Repeatability	≤10% at constant temperature	
Hysteresis	10% typical	
Protection Type	False pulse, transient noise, short circuit, overload (trigger at 250 mA typical)	False pulse, transient noise, short circuit, overload (trigger at 320 mA typical)
Certifications	UL Listed, CSA Certified, and CE Marked for all applicable directives	
Enclosure Type Rating	NEMA 1, 2, 3, 3R, 4, 4X, 6, 6P, 12, 13; IP67 (IEC529)	
Housing Material	Nickel plated brass barrel	
Connection Type	Cable: 2 m (6.5 ft) length, 2-conductor PVC; Quick-disconnect: 3-pin micro, 3-pin mini	
LED	Red: Output energized/Short Circuit (Flashing), Green: Power	
Operating Temperature [C (F)]	-25...+70 ° (-13...+158 °)	
Shock	30 g, 11 ms	
Vibration	55 Hz, 1 mm amplitude, 3 planes	

Correction Factors

Target Material	Correction Factors
Steel	1.0
Stainless Steel	0.9
Brass	0.5
Aluminum	0.45
Copper	0.4

Tubular Sensors 871C 2-Wire AC Full Featured Plastic Face/Threaded Nickel-Plated Brass Barrel

Approximate Dimensions [mm (in.)]

Wiring Diagrams

Cable Style

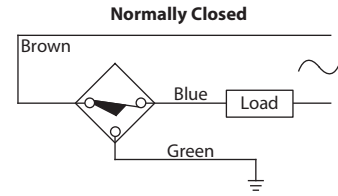
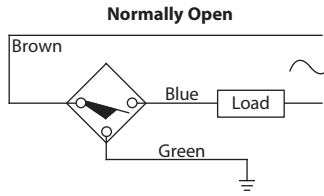
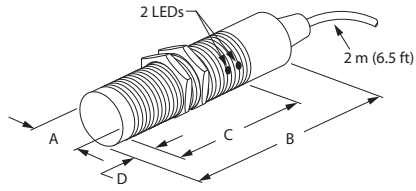

Note: Load can be switched to brown wire.

Thread Size	Shielded	[mm (in.)]			
		A	B	C	D
M12 x 1	Yes	12.0 (0.47)	78.99 (3.11)	47.24 (1.86)	0.8 (0.03)
M18 x 1	Yes	18.0 (0.71)	74.68 (2.94)	61.6 (2.43)	
M30 x 1.5	Yes	30.0 (1.18)	77.52 (3.05)	64.31 (2.53)	

Mini QD Style

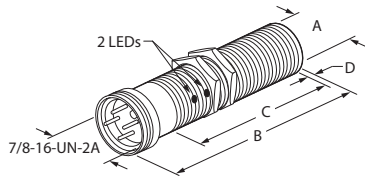

Normally Open or Normally Closed

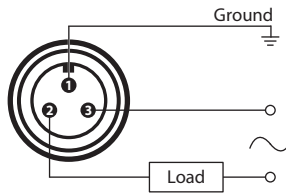

Note: No ground wire on 12 mm. Attach housing to ground.

Note: Load can be switched to pin 3.

Thread Size	[mm (in.)]			
	A	B	C	D
M12 x 1	12.0 (0.47)	93.45 (3.68)	46.08 (1.81)	—
M18 x 1	18.0 (0.71)	75.82 (2.99)	53.92 (2.12)	
M30 X 1.5	30.0 (1.18)	86.66 (3.41)	64.31 (2.53)	

Micro QD Style

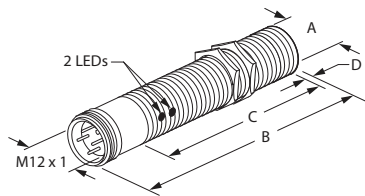

Normally Open or Normally Closed

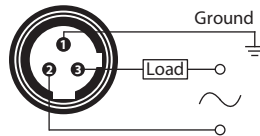

Note: No ground wire on 12 mm. Attach housing to ground.

Note: Load can be switched to pin 2.

Thread Size	[mm (in.)]			
	A	B	C	D
M12 x 1	12.0 (0.47)	90.42 (3.56)	46.99 (1.85)	—
M18 x 1	18.0 (0.71)	83.54 (3.29)	61.6 (2.43)	
M30 X 1.5	30.0 (1.18)	86.00 (3.39)	64.31 (2.53)	

Tubular Sensors

871C 2-Wire AC Plastic Barrel

Plastic Face/Threaded



871C AC Cable Style
18 & 30 mm

Correction Factors

Target Material	Correction Factors
Steel	1.0
Stainless Steel	0.7...0.8
Brass	0.4...0.5
Aluminum	0.3...0.4
Copper	0.3...0.4

Specifications

	18 mm	30 mm
Load Current	≤180 mA	≤300 mA
Inrush Current (1 cycle)	≤1 A	≤3 A
Leakage Current	≤1.7 mA	
Operating Voltage	24...250V AC	
Voltage Drop	≤11V	
Hysteresis	≤20% typical	
Protection Type	Transient noise	
Certifications	CE Marked for all applicable directives	
Enclosure Type Rating	NEMA 1, 2, 3, 4, 4X, 12, 13; IP67 (IEC529)	
Housing Material	Plastic barrel	
Connection Type	Cable: 2 m (6.5 ft) length, 2-conductor PVC	
LED	Red: Output energized	
Operating Temperature [C (F)]	-25...+55 ° (-13...+131 °)	
Shock	30 g, 11 ms	
Vibration	55 Hz, 1 mm amplitude, 3 planes	

Approximate Dimensions [mm (in.)]

Cable Style

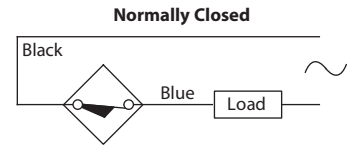
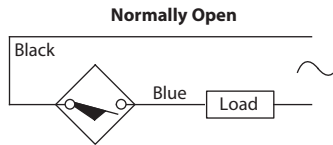
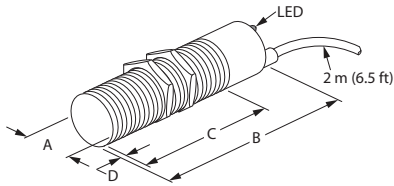

Note: Load can be switched to black wire.

Thread Size	Shielded	[mm (in.)]			
		A	B	C	D
M18 x 1	Yes	18.0 (0.71)	81.0 (3.19)	61.0 (2.40)	2.0 (0.08)
	No ★				
M30 x 1.5	Yes	30.0 (1.18)	81.0 (3.19)	61.0 (2.40)	2.0 (0.08)
	No ★				

★ Unshielded proximity sensors require a metal-free zone around the sensing face. Any metal immediately opposite the sensing face should be no closer than three times the rated nominal sensing distance of the sensor.

Tubular Sensors

871C Analog Output, 3-Wire DC

Plastic Face/Nickel-Plated Brass Barrel



871C Cable Style
12, 18, 30 mm

Correction Factors

Target Material	Correction Factors
Steel	1.0
Stainless Steel	0.7...0.8
Brass	0.4...0.5
Aluminum	0.3...0.4
Copper	0.2...0.3

Approximate Dimensions [mm (in.)]

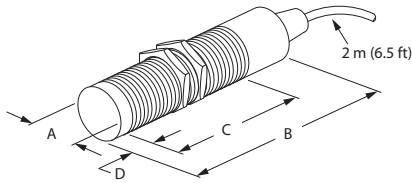

Specifications

	12 mm	18 mm	30 mm
Analog Output	0...10V Sourcing		
Load Current	5 mA		
Operating Voltage	18...30V DC		
Repeatability	≤1%		
Ripple	10%		
Slew Speed	1.0V/ms	0.7V/ms	0.1V/ms
Δ Output/Δ Distance	0.25 mm/V	0.375 mm/V	0.875 mm/V
Linearity Tolerance	6.25%		
Temperature Drift	±0.3V		
Protection Type	Transient noise, reverse polarity, short-circuit, and overload		
Certifications	CE Marked for all applicable directives		
Enclosure Type Rating	NEMA 1, 2, 3, 4, 12, 13; IP67 (IEC529)		
Housing Material	Nickel-plated brass barrel, plastic face (PBT)		
Connection Type	Cable: 2 m (6.5 ft) length, 3-conductor PVC		
LED	None		
Operating Temperature [C (F)]	-25...+70 ° (-13...+158 °)		
Shock	30 g, 11 ms		
Vibration	55 Hz, 1 mm amplitude, 3 planes		

Thread Size	[mm (in.)]			
	A	B	C	D
12 mm	12.0 (0.47)	80 (3.15)	58 (2.28)	12 (0.47)
18 mm	18.0 (0.71)			
30 mm	30.0 (1.18)		70 (2.75)	

Wiring Diagrams

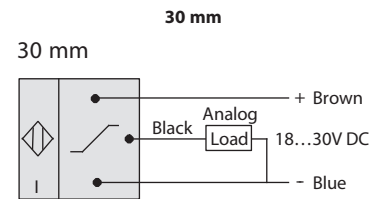
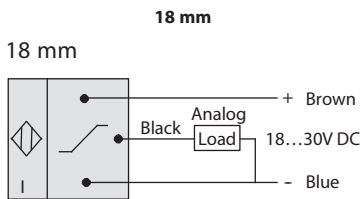
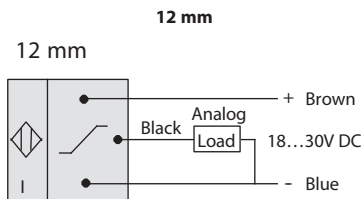

Nominal Output

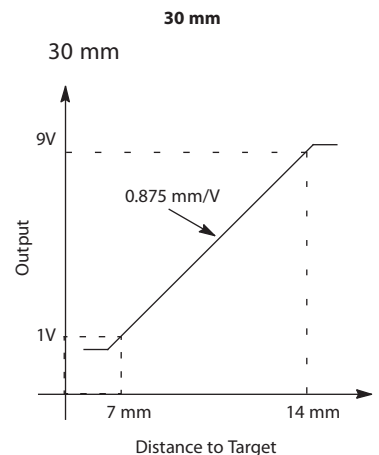
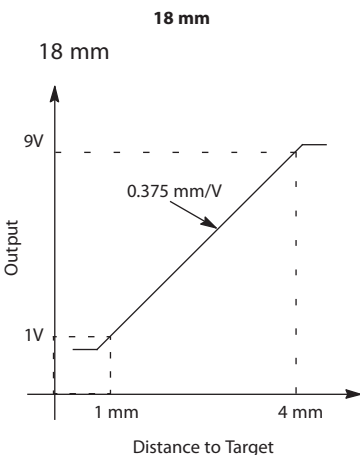
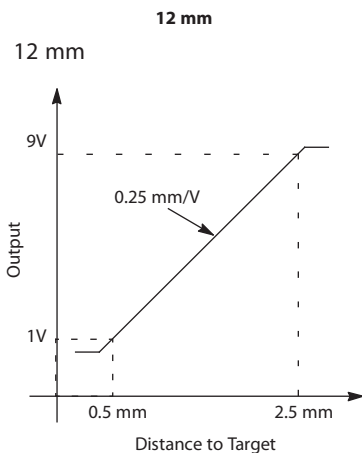

Tubular Sensors
871C 2-Wire NAMUR Intrinsically Safe, Cable Style
 Nickel-Plated Brass Barrel, Plastic Face



871C NAMUR Cable Style
 8, 12, 18, and 30 mm



871C NAMUR Micro Quick-Disconnect Style
 8, 12, 18, and 30 mm

Specifications

Output Type	NAMUR (conforms to DIN 19 234)
Load Current, Nom.	<1 mA (target present), >3 mA (target absent)
Operating Voltage	5...15V DC (8.2V DC nom., Ri = 1 kohm, DIN 19 234)
Ripple	<5%
Repeatability	<10%
Hysteresis	10% typical
Protection Type	Reverse polarity, false pulse, transient noise, short circuit, and overload ★
Certifications	FM Approved: - Class I, II, III; Divisions 1, 2; Groups A, B, C, D, E, F, G; - Class I; Zone 0, 1, 2; Groups IIC, IIB, IIA; T6; CSA Certified: - Class I, II, III; Divisions 1, 2; Groups A, B, C, D, E, F, G; - Class I; Zone 0, 1, 2; Groups IIC, IIB, IIA; CE Marked for all applicable directives
Enclosure Type Rating	NEMA 4, IP67 (IEC529)
Housing Material	Nickel-plated brass barrel, plastic face
Connection Type	Cable: 2 m (6.5 ft) length, 2-conductor #22 AWG PVC, Quick-Disconnect: 4-pin micro style
LED	None
Operating Temperature [C (F)]	-25...+60 ° (-13...+140 °)
Shock	30 g, 11 ms
Vibration	55 Hz, 1 mm amplitude, 3 planes

★ False pulse, transient noise, short circuit, and overload protection are realized in amplifier.

Correction Factors

Target Material	Correction Factors
Steel	1.0
Stainless Steel	0.7...0.8
Brass	0.4...0.5
Aluminum	0.3...0.4
Copper	0.2...0.3

Entity Parameters

Sensor			Barrier
V _{MAX}	16V	≥	V _t
I _{MAX}	60 mA	≥	I _t
C _i	150 nF	≤	C _a
L _i	200 μH	≤	L _a

IMPORTANT



Operating parameters must be adhered to.

Tubular Sensors
871C 2-Wire NAMUR Intrinsically Safe, Cable Style
 Nickel-Plated Brass Barrel, Plastic Face

Approximate Dimensions [mm (in.)]

Wiring Diagrams

Cable Style

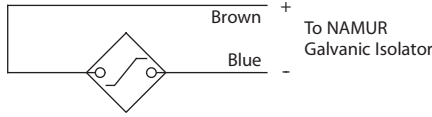
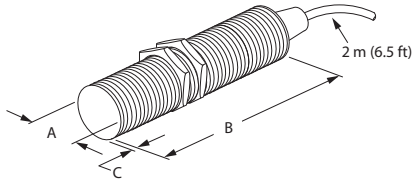

Thread Size	Shielded	[mm (in.)]		
		A	B	C
M8 x 1	Yes	8.0 (0.31)	30.0 (1.18)	—
	No			5.0 (0.20)
M12 X 1	Yes	12.0 (0.47)		—
	No	6.0 (0.24)		
M18 x 1	Yes	18.0 (0.71)		—
	No	8.0 (0.31)		
M30 X 1.5	Yes	30.0 (1.18)	40.0 (1.57)	—
	No			12.0 (0.47)

Micro QD Style

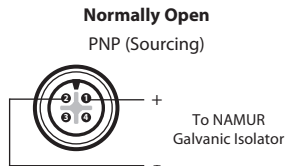
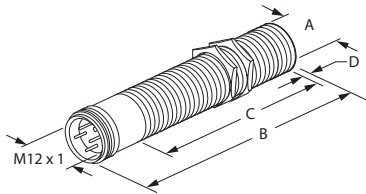

Thread Size	Shielded	[mm (in.)]			
		A	B	C	D
M8 x 1	Yes	8.0 (0.31)	50.0 (1.97)	28.0 (1.10)	—
	No			23.0 (0.91)	5.0 (0.20)
M12 X 1	Yes	12.0 (0.47)		30.0 (1.18)	—
	No	24.0 (0.94)		6.0 (0.24)	
M18 x 1	Yes	18.0 (0.71)		30.0 (1.18)	—
	No			22.0 (0.87)	8.0 (0.31)
M30 X 1.5	Yes	30.0 (1.18)	60.0 (2.36)	40.0 (1.57)	—
	No			28.0 (1.10)	12.0 (0.47)

Tubular Sensors

871C 3-Wire DC Mini Tubular

Plastic Face/Small Threaded or Smooth Stainless Steel Barrel



871C DC Cable Style
Smooth Barrel
3, 4, and 5 mm



871C DC Cable Style
Threaded Barrel
4 & 5 mm



871C DC Pico Quick-Disconnect
Smooth Barrel
4 mm



871C DC Pico Quick-Disconnect
Style Threaded Barrel
5 mm



871C DC Pico Style 3-Pin 6 inch Lead
Smooth Barrel
3 & 4 mm



Specifications

	3 mm Smooth Barrel and 4 mm Threaded Barrel	4 mm Smooth Barrel and 5 mm Threaded Barrel
Certifications	UL Listed and CE Marked for all applicable directives	
Environmental		
Operating Environment	NEMA 1, 2, 3, 4, 12, 13 IP67 (IEC 529)	
Operating Temperature [C (F)]	-25...+70° (-13...+158°)	
Vibration	55 Hz, 1 mm amplitude, 3 planes	
Shock	30 g, 11 ms	
Electrical		
Load Current	≤ 100 mA	<200 mA
Leakage Current	≤ 0.1 mA	
Operating Voltage	10...30V DC	
Voltage Drop	≤ 2V	
Repeatability	≤ 5%	
Hysteresis	10% typical	
Protection Type	False pulse, transient noise, reverse polarity, and short circuit	
IO-Link (enabled on normally open, PNP models only)		
Protocol	IO-Link V1.0	
Interface Type	IO-Link	
Mode	COM 2 (38.4 kBaud)	
Cycle Time 1	10.4 ms, minimum	
SIO (standard I/O)	Supported (pin 4 for either IO-Link or SIO)	
Mechanical		
Housing Material	Stainless steel barrel, polyester face	
LED	Yellow: Output energized	
LED (IO-Link Mode)	Solid yellow: Sensor in IO-Link mode	
Connection Type	Pico QD (M8), 2 m cable, pico with lead	

Correction Factors

Sensor Type/ Target Material	3 mm Dia., Smooth 0.6 mm Sr	3 mm Dia., Smooth 1.0 mm Sr	4 mm Dia., Smooth or Threaded 0.8 mm Sr	4 mm Dia., Smooth or Threaded 1.5 mm Sr	5 mm Dia., Threaded 1 mm Sr	5 mm Dia., Threaded 1.5 mm Sr
Steel	1	1	1	1	1	1
Copper	0.5	0.45	0.45	0.4	0.45	0.4
Aluminum	0.55	0.5	0.5	0.4	0.5	0.4
Brass	0.65	0.6	0.55	0.5	0.55	0.5
Stainless Steel 304	0.8	0.8	0.8	0.75	0.8	0.75

Switching Frequency

Barrel Diameter [mm (in.)]	Nominal Sensing Distance [mm (in.)]	Switching Frequency [Hz]
3	0.6 (0.02)	5000
	1 (0.04)	3000
4	0.8 (0.03)	5000
	1 (0.04)	3000
	1.5 (0.06)	3000
5	1 (0.04)	5000
	1.5 (0.06)	3000

Tubular Sensors 871C 3-Wire DC Mini Tubular Plastic Face/Small Threaded or Smooth Stainless Steel Barrel

Approximate Dimensions [mm (in.)]

Wiring Diagrams

Cable Style

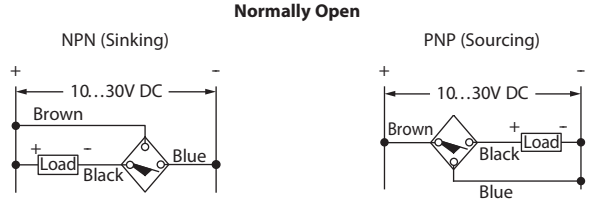
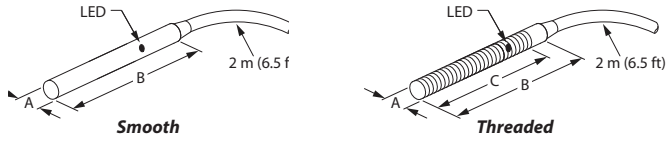

Smooth Diameter	Thread Size	Shielded	[mm (in.)]		
			A	B	C
3.0	—	Yes	3.0 (0.12)	22.0 (0.87)	—
4.0	—		4.0 (0.16)	25.0 (0.98)	—
4.0	M4 x 0.5	Yes	4.0 (0.16)	22.0 (0.87)	19.0 (0.75)
5.0	M5 x 0.5		5.0 (0.20)	25.0 (0.98)	20.0 (0.79)

Pico QD Style

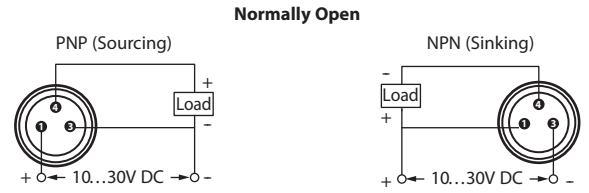
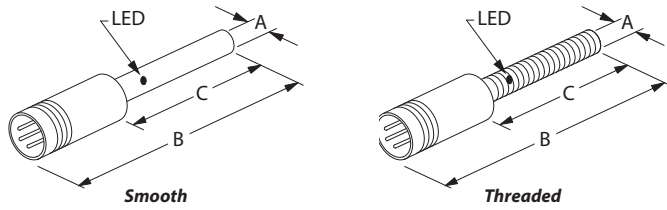

Smooth Diameter	Thread Size	Shielded	[mm (in.)]		
			A	B	C
4.0	—	Yes	4.0 (0.16)	38.0 (1.50)	19.0 (0.74)
5.0	M5 x 0.5		5.0 (0.20)	38.0 (1.50)	23.0 (0.90)

Pico with Lead Style

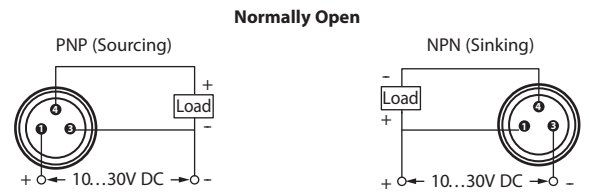
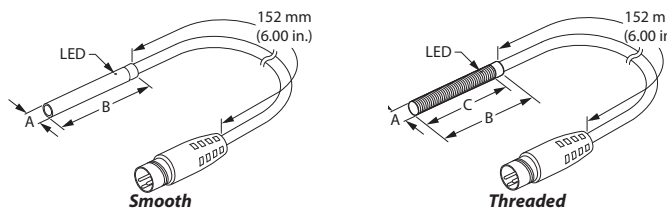

Smooth Diameter	Shielded	[mm (in.)]		
		A	B	C
3.0	Yes	3.0 (0.12)	22.0 (0.87)	—
4.0		4.0 (0.16)	22.0 (0.87)	19.0 (0.74)

Tubular Sensors
871C 3-Wire DC Extended Temperature
 Plastic Face/Threaded Nickel-Plated Brass Barrel



871C DC Cable Style
 12, 18, and 30 mm



871C DC Micro
 Quick-Disconnect Style
 12, 18, and 30 mm

Specifications

Load Current	1...200 mA
Leakage Current	≤10 μA
Operating Voltage	10...30V DC
Voltage Drop	≤2.4V
Repeatability	≤10%
Hysteresis	≤15% typical
Protection Type	False pulse, transient noise, reverse polarity, short circuit, and overload
Certifications	CE Marked for all applicable directives
Enclosure Type Rating	NEMA 1, 2, 3, 4, 12, 13; IP67 (IEC529)
Housing Material	Nickel-plated brass barrel
Connection Type	Cable: 2 m (6.5 ft) length, 3-conductor PUR Quick-Disconnect: 4-pin micro style
LED	Orange: Output Energized
Operating Temperature [C (F)]	-40...+100 ° (-40...+212 °)
Shock	30 g, 11 ms
Vibration	55 Hz, 1 mm amplitude, 3 planes

Correction Factors

Target Material	Correction Factors
Steel	1.0
Stainless Steel	0.9
Brass	0.5
Aluminum	0.45
Copper	0.4

Tubular Sensors
871C 3-Wire DC Extended Temperature
 Plastic Face/Threaded Nickel-Plated Brass Barrel

Approximate Dimensions [mm (in.)]

Wiring Diagrams

Cable Style

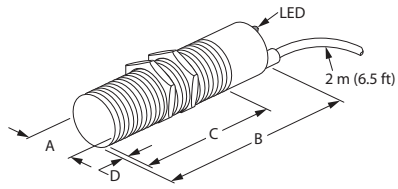

Normally Open
PNP (Sourcing)

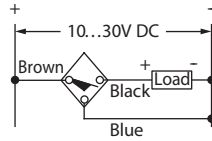

Thread Size	Shielded	[mm (in.)]			
		A	B	C	D
M12 X 1	Yes	12.0 (0.47)	40.0 (1.57)	40.0 (1.57)	—
	No			34.0 (1.34)	6.0 (0.24)
M18 x 1	Yes	18.0 (0.71)		40.0 (1.57)	—
	No			32.0 (1.26)	8.0 (0.31)
M30 X 1.5	Yes	30.0 (1.18)		40.0 (1.57)	—
	No			28.0 (1.12)	12.0 (0.47)

Micro QD Style

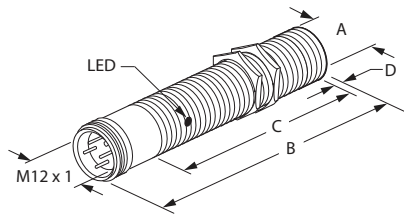

Normally Open
PNP (Sourcing)

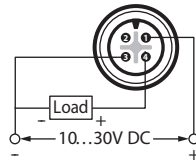

Thread Size	Shielded	[mm (in.)]			
		A	B	C	D
M12 X 1	Yes	12.0 (0.47)	60.0 (2.36)	40.0 (1.57)	—
	No			34.0 (1.34)	6.0 (0.24)
M18 x 1	Yes	18.0 (0.71)		40.0 (1.57)	—
	No			32.0 (1.26)	8.0 (0.31)
M30 X 1.5	Yes	30.0 (1.18)		40.0 (1.57)	—
	No			28.0 (1.12)	12.0 (0.47)

Tubular Sensors

871T 3-Wire DC Stainless Steel Barrel

Plastic Face/Threaded



871T DC Cable Style
12 & 18 mm



871T DC Mini
Quick-Disconnect Style
18 mm

Specifications

	12 mm	18 mm
Load Current	≤300 mA	≤400 mA
Leakage Current	≤10 μA	
Operating Voltage	10...30V DC	
Voltage Drop	≤1V	
Repeatability	≤10%	
Hysteresis	≤10% typical	
Protection Type	False pulse, transient noise, reverse polarity, short circuit, and overload	
Certifications	UL Listed, CSA Certified, and CE Marked for all applicable directives	
Enclosure Type Rating	NEMA 1, 2, 3, 4, 12 and 13; IP67 (IEC529)	
Housing Material	Stainless steel 303 barrel	
Connections	Cable: 3 m (10 ft) length 3-conductor PVC Quick-Disconnect: 4-pin mini style	
LED	Red: output energized	
Operating Temperature [C (F)]	-40...+70 ° (-40...+158 °)	

Correction Factors

Target Material	Correction Factors
Steel	1.0
Stainless Steel	0.7...0.9
Brass	0.3...0.5
Aluminum	0.3...0.4
Copper	0.3...0.4

Approximate Dimensions [mm (in.)]

Cable Style

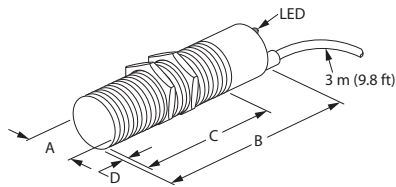

Wiring Diagrams

Normally Open

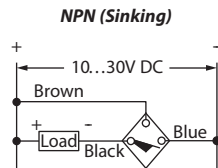

PNP (Sourcing)

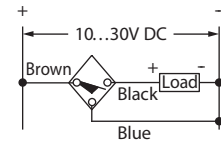

Thread Size	Shielded	[mm (in.)]			
		A	B (max)	C (min)	D (max)
M12 x 1	Yes	12.0 (0.47)	80.0 (3.15)	53.8 (2.12)	0.8 (0.03)
	No			46.5 (1.83)	8.1 (0.32)
M18 x 1	Yes	18.0 (0.71)	81.5 (3.21)	55.6 (2.19)	0.8 (0.03)
	No			43.7 (1.72)	12.3 (0.48)

Mini QD Style

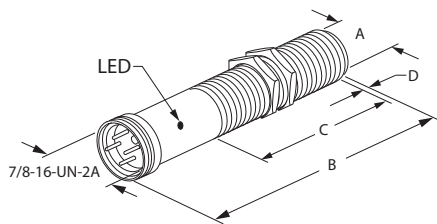

Normally Open

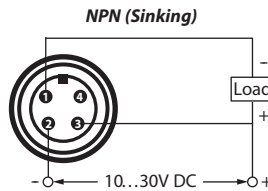

PNP (Sourcing)

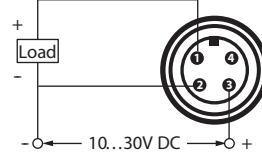

Thread Size	Shielded	[mm (in.)]			
		A	B (max)	C (min)	D (max)
M18 x 1	Yes	18.0 (0.71)	96.9 (3.81)	51.9 (2.04)	0.8 (0.03)
	No			40.4 (1.59)	12.3 (0.48)

Tubular Sensors

871T 2-Wire AC Stainless Steel Barrel Plastic Face/Threaded



871T AC Cable Style
12 & 18 mm



871T AC Mini
Quick-Disconnect Style
18 mm

Specifications

	12 mm	18 mm
Load Current	≤300 mA	≤500 mA
Inrush Current (1 cycle)	≤3 A	≤5 A
Leakage Current	≤1.5 mA	
Operating Voltage	20...132V AC	
Voltage Drop	6.5V AC at 500 mA, 10V AC at 20 mA (RMS)	
Repeatability	≤10%	
Hysteresis	≤10% typical	
Protection Type	False pulse, transient noise	
Certifications	UL Listed, CSA Certified, and CE Marked for all applicable directives	
Enclosure Type Rating	NEMA 1, 2, 3, 4, 12 and 13; IP67 (IEC529)	
Housing Material	Stainless steel 303 barrel	
Connection Type	Cable: 3 m (10 ft) length, 12 mm—2 conductor PVC, 18 mm—3 conductor PVC Quick-Disconnect: 3-pin mini style	
LED	Red: Output Energized	
Operating Temperature [C (F)]	-40...+70 ° (-40...+158 °)	
Shock	30 g, 11 ms	
Vibration	55 Hz, 1 mm amplitude, 3 planes	

Correction Factors

Target Material	Correction Factors
Steel	1.0
Stainless Steel	0.7...0.9
Brass	0.3...0.5
Aluminum	0.3...0.4
Copper	0.3...0.4

Approximate Dimensions [mm (in.)]

Cable Style

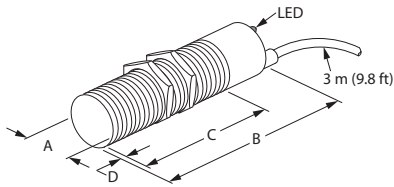

Wiring Diagrams

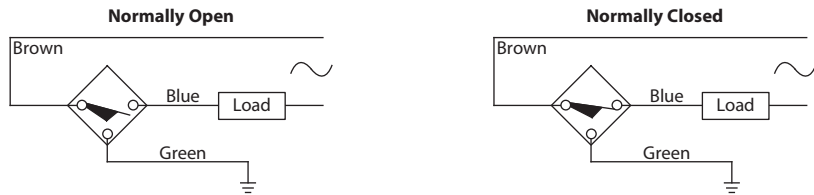

Note: No green wire on 12 mm. Attach housing to ground.

Thread Size	Shielded	[mm (in.)]			
		A	B	C	D
M12 x 1	Yes	12.0 (0.47)	80.0 (3.15)	53.8 (2.12)	0.8 (0.03)
	No			46.5 (1.83)	8.1 (0.32)
M18 x 1	Yes	18.0 (0.71)	81.5 (3.21)	55.6 (2.19)	0.8 (0.03)
	No			43.7 (1.72)	12.3 (0.48)

Mini QD Style

Normally Open or Normally Closed

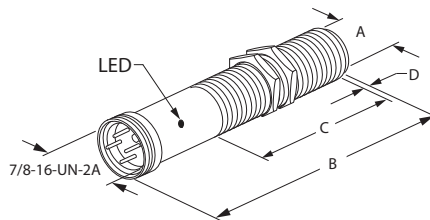
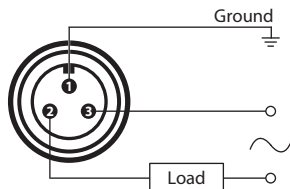

Note: Load can be switched to pin 3.

Thread Size	Shielded	[mm (in.)]			
		A	B	C	D
M18 x 1	Yes	18.0 (0.71)	96.9 (3.81)	51.9 (2.04)	0.8 (0.03)
	No			40.4 (1.59)	12.3 (0.48)

Tubular Sensors
871T 4-Wire AC Ferrous Selective
 Stainless Steel Face/Threaded Stainless Steel Barrel



871T AC Cable Style
18 mm



871T AC Mini
Quick-Disconnect Style
18 mm

Specifications

Load Current	≤500 mA
Inrush Current (1 Cycle)	≤5 A
Supply Current (minimum)	5 mA
Leakage Current	≤1.7 mA
Operating Voltage	20...132V AC
Voltage Drop	N.O. output: 6.5V AC at 500 mA, 10V AC at 20 mA (RMS), N.C. output: 1.7V AC at 500 mA (RMS)
Isolation Voltage	800V AC (output to output); 1500V AC (output to housing)
Repeatability	≤10%
Hysteresis	≤10% typical
Protection Type	False pulse, transient noise
Certifications	CE Marked for all applicable directives
Enclosure Type Rating	NEMA 3, 4, 12 and 13; IP67 (IEC529)
Housing Material	Stainless steel face and barrel
Connections	Cable: 3.6 m (12 ft) length, 5-conductor PVC, Quick-Disconnect: 5-pin mini style
LED	Red: Output Energized, Green: Power
Operating Temperature [C (F)]	0...70 ° (32...158 °)

Correction Factors

Target Material	Correction Factors
Steel	1.0
Stainless Steel ★	0.8...1.1
Brass	0.0
Aluminum	0.0
Copper	0.0

★ Stainless steel containing carbon.

Tubular Sensors
871T 4-Wire AC Ferrous Selective
 Stainless Steel Face/Threaded Stainless Steel Barrel

Approximate Dimensions [mm (in.)]

Wiring Diagrams

Cable Style

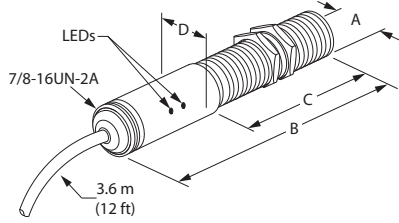

Complementary Normally Open and Normally Closed

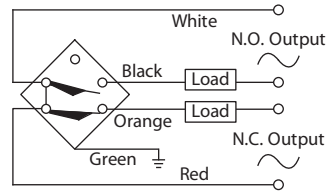

Note:

1. N.O. output must be wired for operation. N.C. output is optional.
2. N.O. load can be switched to white wire.
3. N.C. load can be switched to red wire.

Thread Size	[mm (in.)]			
	A	B	C	D
M18 x 1	18.0 (0.71)	101.6 (4.00)	50.8 (2.00)	20.3 (0.80)

Mini QD Style

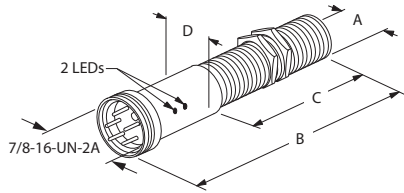

Normally Open and Normally Closed

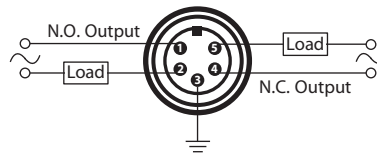

Note:

1. N.O. output must be wired for operation. N.C. output is optional.
2. N.O. load can be switched to pin 1.
3. N.C. load can be switched to pin 4.

Thread Size	[mm (in.)]			
	A	B	C	D
M18 x 1	18.0 (0.71)	101.6 (4.00)	50.8 (2.00)	20.3 (0.80)

Tubular Sensors
871TM 3-Wire DC Short Barrel
 Stainless Steel Face/Threaded Stainless Steel Barrel



871TM DC Cable Style
 12, 18, and 30 mm



871TM DC Mini Quick-Disconnect Style
 12, 18, and 30 mm



871TM DC Micro Quick-Disconnect Style
 12, 18, and 30 mm

Specifications

Load Current	≤200 mA
Capacitive Load	≤1 μF
Leakage Current	≤10 μA
Operating Voltage	10...30V DC
Voltage Drop	≤1V DC at 200 mA
Repeatability	≤10% at constant temperature
Hysteresis	10% typical
Protection Type	False pulse, transient noise, reverse polarity, short circuit (trigger at 340 mA typical), overload
Certifications	UL Listed, CSA Certified, and CE Marked for all applicable directives
Enclosure Type Rating	NEMA 1, 2, 3, 3R, 4, 4X, 6, 6P, 12, 13 IP67 (IEC529) all models; 1200 psi (8270 kPa) washdown; ToughLink™ and micro connector versions are also rated IP69K (IEC 529)
Housing Material	Stainless steel face and barrel
Connection Type	Cable: 2 m (6.5 ft) length, A2 - 3-conductor PVC, C2 - 3-conductor #22 AWG ToughLink™, H2 - 3-conductor #18 AWG ToughLink; Quick-Disconnect: 4-pin mini style, 4-pin micro style
Indicator LEDs	Red: Output Energized, Green: Power/Short Circuit (flashing)—18 mm models only
Operating Temperature [C (F)]	-25...+70 ° (-13...+158 °)
Shock	30 g, 11 ms
Vibration	55 Hz, 1 mm amplitude, 3 planes

Correction Factors

Target Material	Correction Factor
Steel	1.0
Stainless Steel	0.9...1.0
Brass	0.3...0.5
Aluminum	0.1...0.4
Aluminum (≤0.02 Thick)	0.9...1.1
Copper	0.4...0.6

Tubular Sensors

871TM 3-Wire DC Short Barrel

Stainless Steel Face/Threaded Stainless Steel Barrel

Approximate Dimensions—mm (inches)

Typical Wiring Diagrams

Cable Style

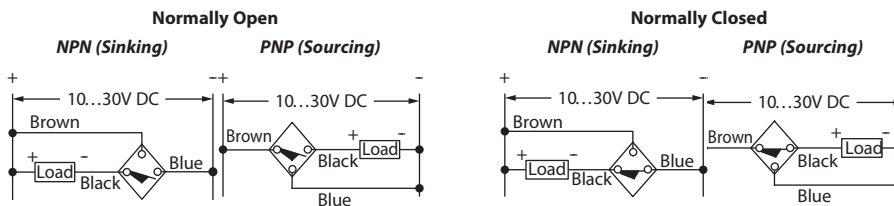
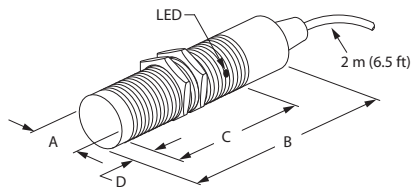

Thread Size	Shielded	[mm (in.)]			
		A	B	C	D
M12 x 1	Yes	12.0 (0.47)	49.8 (1.96)	26.4 (1.04)	2.5 (0.10)
	No			19.5 (0.77)	9.4 (0.37)
M18 x 1	Yes	18.0 (0.71)	55.4 (2.18)	41.7 (1.64)	2.5 (0.10)
	No			14.5 (0.57)	14.5 (0.57)
M30 x 1.5	Yes	30.0 (1.18)	57.9 (2.28)	41.9 (1.65)	2.5 (0.10)
	No			39.4 (1.55)	18.0 (0.71)

Mini QD Style

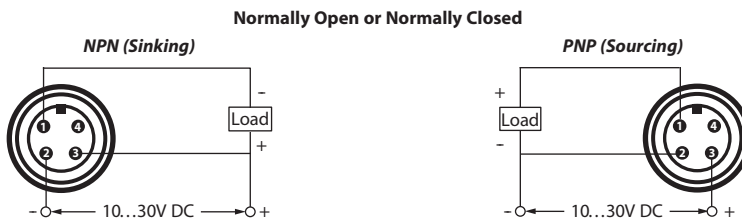
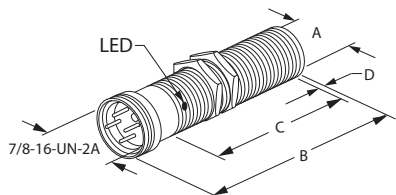

Thread Size	Shielded	[mm (in.)]			
		A	B	C	D
M12 x 1	Yes	12.0 (0.47)	63.5 (2.50)	25.4 (1.00)	2.5 (0.10)
	No			18.5 (0.73)	9.4 (0.37)
M18 x 1	Yes	18.0 (0.71)	56.1 (2.21)	35.1 (1.38)	2.5 (0.10)
	No			29.2 (1.15)	14.5 (0.57)
M30 x 1.5	Yes	30.0 (1.18)	68.1 (2.68)	41.9 (1.65)	2.5 (0.10)
	No			39.4 (1.55)	18.0 (0.71)

Micro QD Style

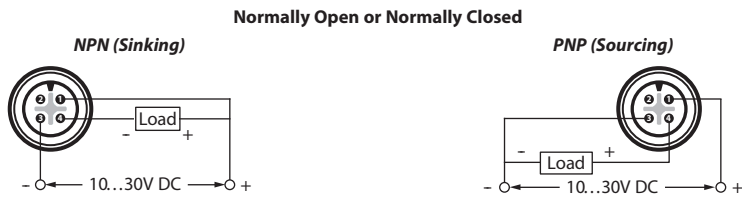
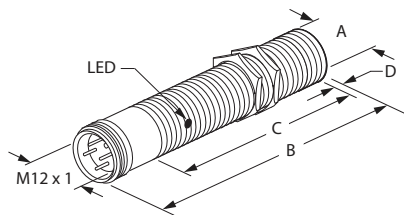

Thread Size	Shielded	[mm (in.)]			
		A	B	C	D
M12 x 1	Yes	12.0 (0.47)	61.0 (2.40)	26.4 (1.04)	2.5 (0.10)
	No			28 (1.10)	9.4 (0.37)
M18 x 1	Yes	18.0 (0.71)	65.0 (2.56)	41.7 (1.64)	2.5 (0.10)
	No			14.5 (0.57)	14.5 (0.57)
M30 x 1.5	Yes	30.0 (1.18)	66.3 (2.61)	41.9 (1.65)	2.5 (0.10)
	No			39.4 (1.55)	18.0 (0.71)

Tubular Sensors
871TM 3-Wire DC Weld-Field Immune
 Stainless Steel Face/Threaded Stainless Steel Barrel



871TM Pico
Quick-Disconnect Style
8 mm



871TM DC Micro
Quick-Disconnect Style
12 mm



871TM DC Micro
18 mm

Specifications

Load Current	≤ 200 mA
Leakage Current	≤ 0.1 mA
Operating Voltage	10...30V DC
Voltage Drop	≤ 2V DC at 200 mA
Repeatability	≤ 5% at constant temperature, maximum sensing range
Hysteresis	15% typical
Protection Type	False pulse, transient noise, reverse polarity, short circuit (trigger at 340 mA typical), overload
Certifications	cULus Listed and CE Marked for all applicable directives
Enclosure Type Rating	8/12/18 mm: IP68/IP69K
Housing Material	Stainless steel face and barrel, resistant to welding splatter
Connection Type	Quick-Disconnect: 4-pin micro style, 3-pin pico style
Indicator LEDs	Yellow: Output energized/360° LED visibility flashing LED indicates target located between 80...100% of rated sensing distance
Operating Temperature [C (F)]	-25...+85 ° (-13...+185 °)
Shock	30 g, 11 ms
Vibration	55 Hz, 1 mm amplitude, 3 planes
Weld-Field Immunity	≤ 40 mT

Correction Factors

Type of Material	Barrel Size and Sensing Range		
	M8	M12	M18
	3 mm	6 mm	10 mm
Steel	1.00		
Copper	1.00	0.85	1.15
Aluminum	1.00	1.00	1.40
Brass	1.30	1.30	1.50
Stainless Steel 1 mm/2 mm	0.4/0.7	0.5/0.9	0.1/0.6

Tubular Sensors
871TM 3-Wire DC Weld-Field Immune
 Stainless Steel Face/Threaded Stainless Steel Barrel

Approximate Dimensions—mm (inches)

Typical Wiring Diagrams

Micro QD Style

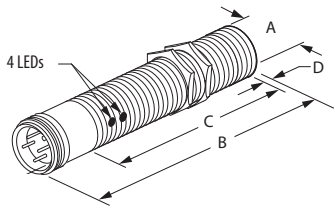

Normally Open

PNP (Sourcing)

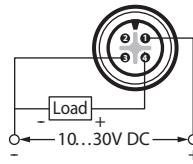

Thread Size	Shielded	[mm (in.)]			
		A	B	C	D
M12 x 1	Yes	12.0 (0.47)	60 (2.36)	41 (1.61)	—
M18 x 1	Yes	18.0 (0.71)	63.5 (2.5)	42.5 (1.67)	—

Pico QD Style

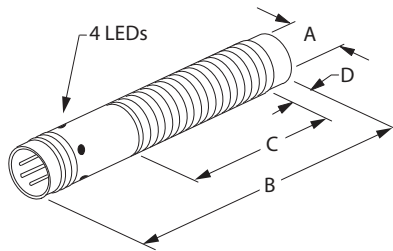

Normally Open

PNP (Sourcing)

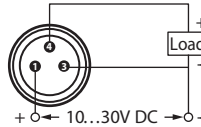

Thread Size	Shielded	[mm (in.)]			
		A	B	C	D
M8 x 1	Yes	8.0 (0.31)	60 (2.35)	45.5 (1.79)	—

Tubular Sensors
871TM 3-Wire DC Long-Range Sensing
 Stainless Steel Face/Threaded Stainless Steel Barrel



871TM Pico
Quick-Disconnect Style
8 mm



871TM DC Micro
Quick-Disconnect Style
12 mm



871TM DC Cable Style
18 mm



871TM DC Micro
Quick-Disconnect Style
30 mm



Specifications

Load Current	≤ 200 mA
Capacitive Load	≤ 1 mF
Leakage Current	≤ 0.1 mA
Operating Voltage	10...30V DC
Voltage Drop	≤ 2V DC at 200 mA
Repeatability	≤ 5% at constant temperature
Hysteresis	10% typical
Protection Type	False pulse, transient noise, reverse polarity, short circuit (trigger at 340 mA typical), overload
Certifications	cULus Listed and CE Marked for all applicable directives
Enclosure Type Rating	12/18/30 mm: IP68/IP69K 8 mm quick-disconnect models: IP67 8 mm cable models: IP68
Housing Material	Stainless steel face and barrel
Connection Type	Cable: 2 m (6.5 ft) length Quick-Disconnect: 4-pin micro style, 3-pin pico style
Indicator LEDs	Yellow: Output energized/360° LED visibility flashing LED indicates target located between 80...100% of rated sensing distance
Operating Temperature	-25...+70 ° (-13...+158 °)
Shock	30 g, 11 ms
Vibration	55 Hz, 1 mm amplitude, 3 planes
IO-Link (enabled on normally open, PNP models only)	
Protocol	IO-Link V1.0
Interface-Type	IO-Link
Mode	COM2 (38.4 kBaud)
Cycle Time	8 ms minimum
SIO (Standard I/O)	Supported (pin 4 for either IO-Link or SIO)

Switching Frequency

Barrel Diameter [mm]	Switching Frequency [Hz]
8	700
12	400
18	200
30	80

Tubular Sensors
871TM 3-Wire DC Long-Range Sensing
 Stainless Steel Face/Threaded Stainless Steel Barrel

Correction Factors

Instructions for unshielded sensor: To determine the appropriate correction factor, only use Table 1. Multiply the sensor type with the target material by the sensing range to determine de-rated sensing distance, if applicable.

Instructions for shielded sensor: To determine the appropriate correction factor, use Table 1 and Table 2. In Table 1, determine the appropriate correction factor based on the type and the target material. Then in Table 2, multiply the result from Table 1 by the material the sensor is mounted in. This number is the final correction factor.

Table 1

Sensor Type/ Target Material (No Surrounding Metal)	8 mm Dia.		12 mm Dia.		18 mm Dia.		30 mm Dia.	
	Shielded	Unshielded	Shielded	Unshielded	Shielded	Unshielded	Shielded	Unshielded
Steel	1	1	1	1	1	1	1	1
Copper	0.9	0.85	0.85	0.8	0.8	0.9	0.9	0.9
Aluminum	1	1	1	1	1	1	1	1
Brass	1.35	1.4	1.3	1.4	1.2	1.35	1.3	1.2
Stainless Steel	0.3/0.6	0.3/0.9	0.5/0.9	NA/0.65	0.5/0.9	0.2/0.7	0.35/0.7	NA/0.25

Table 2

Surrounding Material Type	8 mm Dia.	12 mm Dia.	18 mm Dia.	30 mm Dia.
	Shielded			
Steel	1	0.7	0.75	0.9
Aluminum	0.9	1.15	0.9	0.7
Brass	0.9	1.05	0.75	0.6
Stainless Steel	1	0.8	0.8	1.3

The table below indicates the protrusion distance from the mounting device for the unshielded sensor face.

Surrounding Material Type	8 mm Dia.	12 mm Dia.	18 mm Dia.	30 mm Dia.
	Unshielded			
Steel	15 mm	22 mm	36 mm	18 mm
Aluminum	9 mm	13 mm	22 mm	34 mm
Brass	10 mm	15 mm	22 mm	34 mm
Stainless Steel	14 mm	21 mm	43 mm	18 mm

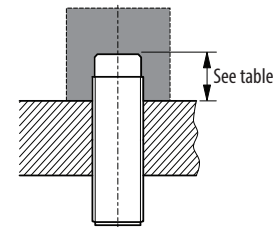

Tubular Sensors

871TM 3-Wire DC Long-Range Sensing

Stainless Steel Face/Threaded Stainless Steel Barrel

Approximate Dimensions—mm (inches)

Typical Wiring Diagrams

Cable Style

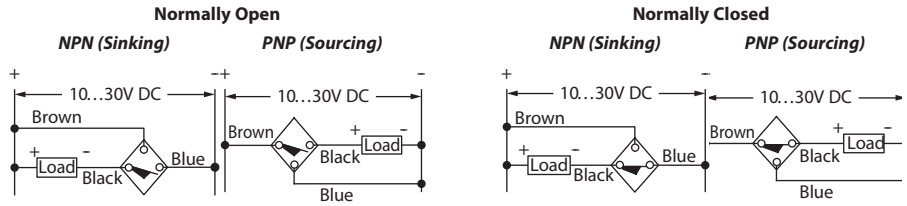
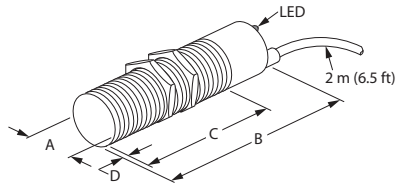

Thread Size	Shielded	[mm (in.)]			
		A	B	C	D
M8 x 1	Yes	8.0 (0.31)	45 (1.76)	45 (1.76)	—
	No			41 (1.61)	4 (0.16)
M12 x 1	Yes	12.0 (0.47)	50 (1.96)	50 (1.96)	—
	No			45 (1.77)	5 (0.19)
M18 x 1	Yes	18.0 (0.71)	50 (1.96)	50 (1.96)	—
	No			43 (1.69)	7 (0.27)
M30 x 1.5	Yes	30.0 (1.18)	50 (1.96)	50 (1.96)	—
	No			40 (1.57)	10 (0.39)

Micro QD Style

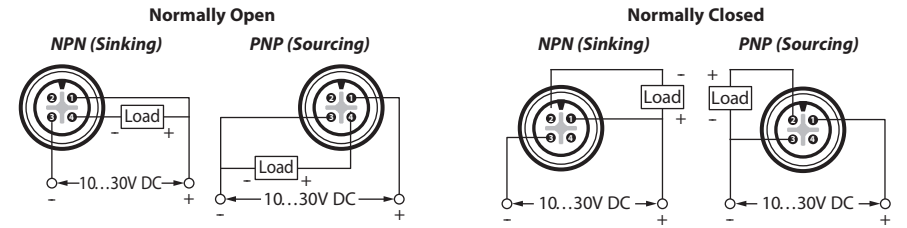
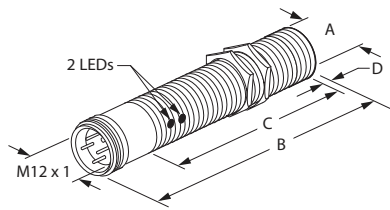

Thread Size	Shielded	[mm (in.)]			
		A	B	C	D
M8 x 1	Yes	8.0 (0.31)	66 (2.59)	46 (1.81)	—
	No			42 (1.65)	4 (0.16)
M12 x 1	Yes	12.0 (0.47)	60 (2.36)	41 (1.61)	—
	No			36 (1.42)	5 (0.19)
M18 x 1	Yes	18.0 (0.71)	63.5 (2.5)	42.5 (1.67)	—
	No			35.5 (1.40)	7 (0.27)
M30 x 1.5	Yes	30.0 (1.18)	66.3 (2.61)	42.5 (1.67)	—
	No			32.5 (1.28)	10 (0.39)

Pico QD Style

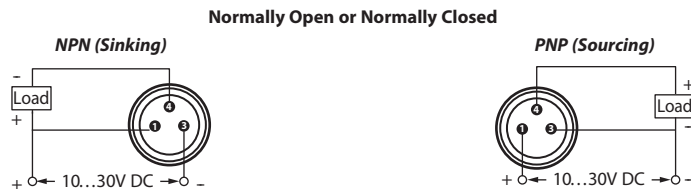
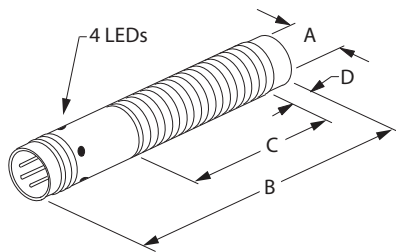

Thread Size	Shielded	[mm (in.)]			
		A	B (max.)	C (min.)	D (max.)
M8 x 1	Yes	8.0 (0.31)	60 (2.35)	45.5 (1.79)	—
	No			41.5 (1.63)	4.0 (0.16)

Tubular Sensors

871TM 3-Wire DC Ferrous or Nonferrous Selective Stainless Steel Face/Threaded Stainless Steel Barrel



**871TM DC Micro
Quick-Disconnect Style
12, 18, and 30 mm**



**871TM DC ToughLink
Cable Style
12, 18, and 30 mm**



**871TM DC Mini
Quick-Disconnect Style
12, 18, and 30 mm**



**871TM DC Cable Style
12, 18, and 30 mm**

Specifications

Load Current	≤200 mA
Capacitive Load	≤1 μF
Leakage Current	≤10 μA
Operating Voltage	10...30V DC
Voltage Drop	≤1V DC at 200 mA
Repeatability	≤10% at constant temperature
Hysteresis	10% typical
Protection Type	False pulse, transient noise, reverse polarity, short circuit (trigger at 340 mA typical), overload
Certifications	UL Listed, CSA Certified, and CE Marked for all applicable directives
Enclosure Type Rating	NEMA 1, 2, 3, 3R, 4, 4X, 6, 6P, 12, 13; IP67 (IEC529) all models; 1200 psi (8270 kPa) washdown; ToughLink™ and micro connector versions are also rated IP69K (IEC 529)
Housing Material	Stainless steel face and barrel
Connection Type	Cable: 2 m (6.5 ft) length, A2 - 3-conductor PVC, C2 - 3-conductor #22 AWG ToughLink™, H2 - 3-conductor #18 AWG ToughLink; Quick-Disconnect: 4-pin mini style, 4-pin micro style
Indicator LEDs	Red: Output Energized, Green: Power/Short Circuit (flashing)—18 mm models only
Operating Temperature [C (F)]	-25...+70 ° (-13...+158 °)
Shock	30 g, 11 ms
Vibration	55 Hz, 1 mm amplitude, 3 planes

Correction Factors

Target Material	Correction Factor	
	Ferrous Selective	Nonferrous Selective
Steel	1.0	0.0
Stainless Steel	0...1.0 ★	0...1.0 ★
Brass	0.0	1.0
Aluminum	0.0	1.0
Aluminum (>0.003 thick)	0.0	1.0
Copper	0.0	1.0

★ Variation due to differences in alloy composition.

Tubular Sensors

871TM 3-Wire DC Ferrous or Nonferrous Selective

Stainless Steel Face/Threaded Stainless Steel Barrel

Approximate Dimensions—mm (inches)

Typical Wiring Diagrams

Cable Style

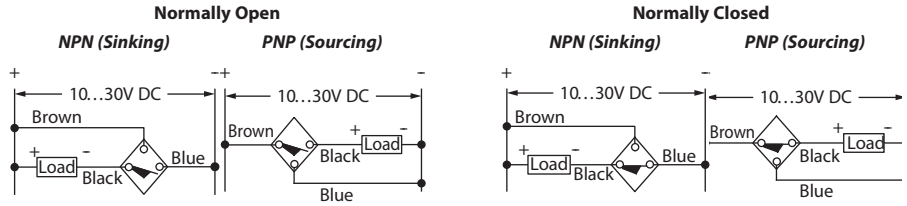
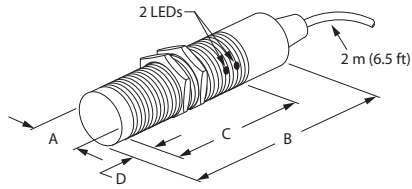

LEDs available on 18 mm models only

Thread Size	Shielded	Target Type	[mm (in.)]			
			A	B	C	D
M12 x 1	Yes	Ferrous	12.0 (0.47)	51.0 (2.01)	27.5 (1.08)	—
M18 x 1		Ferrous	18.0 (0.71)	76.8 (3.02)	65.0 (2.56)	—
		Nonferrous	18.0 (0.71)	74.7 (2.94)	60.0 (2.36)	2.5 (0.10)
M30 x 1.5		Nonferrous	30.0 (1.18)	77.5 (3.05)	63.0 (2.48)	2.5 (0.10)

Mini QD Style

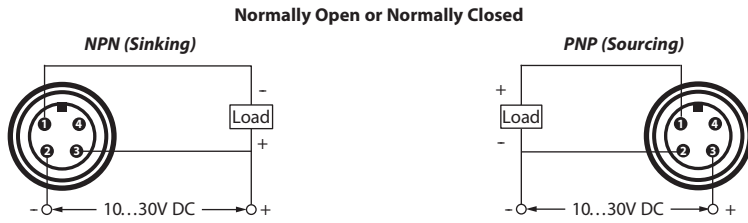
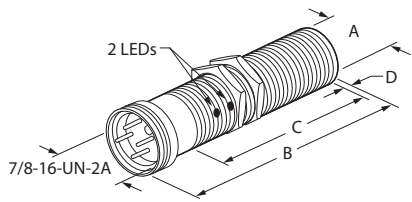

LEDs available on 18 mm models only

Thread Size	Shielded	Target Type	[mm (in.)]			
			A	B	C	D
M12 x 1	Yes	Ferrous	12.0 (0.47)	61.3 (2.45)	30.4 (1.20)	—
M18 x 1		Ferrous	18.0 (0.71)	78.5 (3.14)	60.0 (2.36)	—
		Nonferrous	18.0 (0.71)	76.6 (3.02)	54.9 (2.16)	2.5 (0.10)
M30 x 1.5		Nonferrous	30.0 (1.18)	86.0 (3.39)	63.5 (2.50)	2.5 (0.10)

Micro QD Style

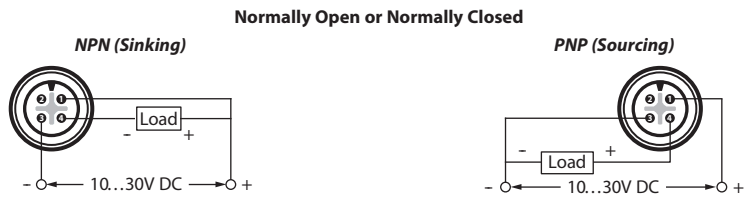
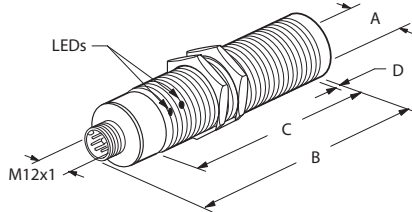

LEDs available on 18 mm models only

Thread Size	Shielded	Target Type	[mm (in.)]			
			A	B	C	D
M12 x 1	Yes	Ferrous	12.0 (0.47)	62.3 (2.45)	30.4 (1.20)	0.9 (0.04)
M18 x 1		Ferrous	18.0 (0.71)	85.0 (3.35)	65.5 (2.58)	2.0 (0.08)
		Nonferrous	18.0 (0.71)	84.3 (3.32)	60.0 (2.36)	2.5 (0.10)
M30 x 1.5		Nonferrous	30.0 (1.18)	85.5 (3.37)	63.0 (2.48)	2.5 (0.10)

Tubular Sensors
871TM 2-Wire DC Short Barrel
 Stainless Steel Face/Threaded Stainless Steel Barrel



871TM DC Cable Style
 12, 18, and 30 mm



871TM DC Mini Quick-Disconnect Style
 12, 18, and 30 mm



871TM DC Micro Quick-Disconnect Style
 12, 18, and 30 mm

Specifications

Load Current	≤25 mA
Load Current, Min.	2 mA
Leakage Current	≤0.9 mA
Operating Voltage	10...30V DC
Voltage Drop	≤8V
Repeatability	10% typical
Hysteresis	10% typical
Protection Type	False pulse, transient noise, reverse polarity, short circuit, overload
Certifications	UL Listed, CSA Certified, and CE Marked for all applicable directives
Enclosure Type Rating	NEMA 1, 2, 3, 3R, 4, 4X, 6, 6P, 12, 13; IP67 (IEC 529) all models; 1200 psi (8270 kPa) washdown; ToughLink™ and micro connector versions are also rated IP69K (IEC 529)
Housing Material	Stainless steel face and barrel
Connection Type	Cable: 2 m (6.5 ft) length, A2 - 2-conductor PVC, C2 - 2-conductor #22 AWG ToughLink™, H2 - 2-conductor #18 AWG ToughLink; Quick-Disconnect: 4-pin mini style, 4-pin micro style
Indicator LEDs	Red: Output Energized
Operating Temperature [C (F)]	-25...+70 ° (-13...+158 °)
Shock	30 g, 11 ms
Vibration	55 Hz, 1 mm amplitude, 3 planes

Correction Factors

Target Material	Correction Factor
Steel	1.0
Stainless Steel	0.9...1.0
Brass	0.3...0.5
Aluminum	0.1...0.4
Aluminum (≤0.02 Thick)	0.9...1.1
Copper	0.4...0.6

Tubular Sensors

871TM 2-Wire DC Short Barrel

Stainless Steel Face/Threaded Stainless Steel Barrel

Approximate Dimensions—mm (inches)

Typical Wiring Diagrams

Cable Style

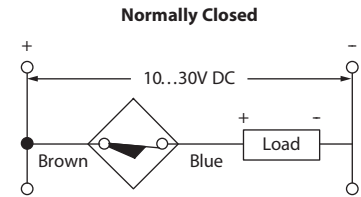
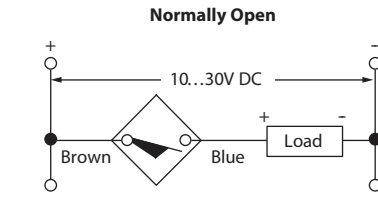
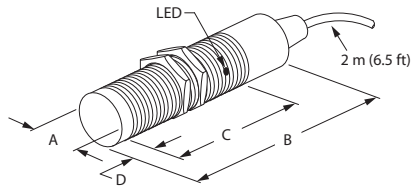

Note: Load can be switched to brown wire.

Thread Size	Shielded	[mm (in.)]			
		A	B	C	D
M12 x 1	Yes	12.0 (0.47)	49.8 (1.96)	26.4 (1.04)	2.5 (0.10)
	No			19.5 (0.77)	9.4 (0.37)
M18 x 1	Yes	18.0 (0.71)	55.4 (2.18)	41.7 (1.64)	2.5 (0.10)
	No			14.5 (0.57)	14.5 (0.57)
M30 x 1.5	Yes	30.0 (1.18)	57.9 (2.28)	41.9 (1.65)	2.5 (0.10)
	No			39.4 (1.55)	18.0 (0.71)

Mini QD Style

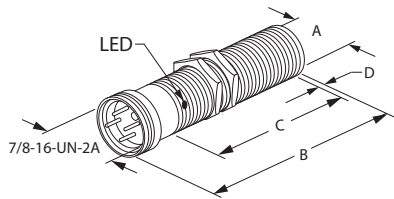

Normally Open or Normally Closed

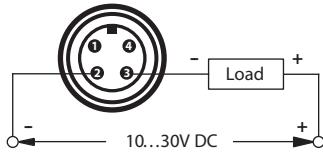

Note: Load can be switched to pin 2.

Thread Size	Shielded	[mm (in.)]			
		A	B	C	D
M12 x 1	Yes	12.0 (0.47)	63.5 (2.50)	25.4 (1.00)	2.5 (0.10)
	No			18.5 (0.73)	9.4 (0.37)
M18 x 1	Yes	18.0 (0.71)	56.1 (2.21)	35.1 (1.38)	2.5 (0.10)
	No			29.2 (1.15)	14.5 (0.57)
M30 x 1.5	Yes	30.0 (1.18)	68.1 (2.68)	41.9 (1.65)	2.5 (0.10)
	No			39.4 (1.55)	18.0 (0.71)

Micro QD Style

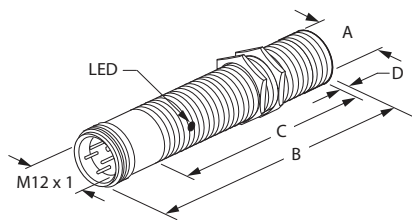

Normally Open or Normally Closed

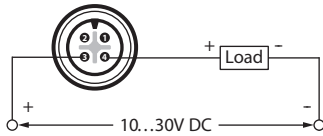

Note: Load can be switched to pin 3.

Thread Size	Shielded	[mm (in.)]			
		A	B	C	D
M12 x 1	Yes	12.0 (0.47)	61.0 (2.40)	26.4 (1.04)	2.5 (0.10)
	No			19.6 (0.77)	9.4 (0.37)
M18 x 1	Yes	18.0 (0.71)	65.0 (2.56)	41.7 (1.64)	2.5 (0.10)
	No			14.5 (0.57)	14.5 (0.57)
M30 x 1.5	Yes	30.0 (1.18)	66.3 (2.61)	41.9 (1.65)	2.5 (0.10)
	No			39.4 (1.55)	18.0 (0.71)

Tubular Sensors
871TM 2-Wire AC/DC All Stainless Steel
 Stainless Steel Face/Threaded Stainless Steel Barrel



871TM AC/DC Cable Style
12, 18, and 30 mm



871TM AC/DC Mini Quick-Disconnect Style
12, 18, and 30 mm



871TM AC/DC Micro Quick-Disconnect Style
12, 18, and 30 mm



871TM AC/DC EAC Micro Quick-Disconnect Style
12 mm



871TM AC/DC ToughLink Cable Style
12, 18, and 30 mm

Specifications

	12 mm	18 & 30 mm
Load Current	5...200 mA	5...250 mA
Inrush Current (1 cycle)	≤2 A	≤4 A
Leakage Current	≤1.9 mA @ 120V AC	
Operating Voltage	20...250V AC/DC	
Voltage Drop	≤10V @ 5...200 mA	≤10V @ 5...250 mA
Repeatability	≤10% at constant temperature	
Hysteresis	7% typical	
Protection Type	False pulse, transient noise, short-circuit (trigger @ 5 A typical), and overload (trigger @ 260 mA typical)	False pulse, transient noise, short-circuit (trigger @ 8 A typical), and overload (trigger @ 320 mA typical)
Certifications	UL Listed, CSA Certified, and CE Marked for all applicable directives CCC Certified (select models)	
Enclosure Type Rating	NEMA 1, 2, 3, 3R, 4, 4X, 6, 6P, 12, 13; IP67 (IEC 529) all models; 1200 psi (8270 kPa) washdown; ToughLink™ and micro connector versions are also rated IP69K (IEC 529)	
Housing Material	Stainless steel face and barrel	
Connection Type	Cable: 2 m (6.5 ft) length; A2—2-conductor #22 AWG PVC, C2—2-conductor #22 AWG ToughLink, H2—3-conductor #18 AWG ToughLink; Quick-Disconnect: 3-pin mini style, 3-pin micro style, 4-pin EAC micro style	
Indicator LEDs	Red: Output energized, Green: Power, Short circuit: Red and green flashing	
Operating Temperature [C (F)]	-25...+70 ° (-13...+158 °)	
Shock	30 g, 11 ms	
Vibration	55 Hz, 1 mm amplitude, 3 planes	

Correction Factors

Target Material	Correction Factor
Steel	1.0
Stainless Steel	0.9...1.0
Brass	0.3...0.5
Aluminum	0.1...0.4
Aluminum (≤0.02 Thick)	0.9...1.1
Copper	0.4...0.6

Approximate Dimensions — mm (in.)

EAC Micro QD Style

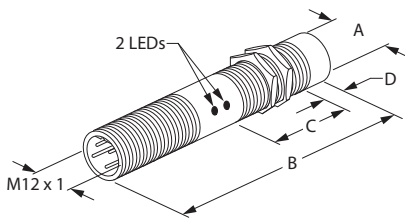

Typical Wiring Diagrams

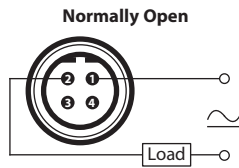

Note: No ground pin. Attach housing to ground.
Note: Load can be switched to pin 2.

Thread Size	Shielded	[mm (in.)]			
		A	B	C	D
M12 x 1	No	12.0 (0.47)	83.0 (3.27)	31.7 (1.25)	9.4 (0.37)

Tubular Sensors

871TM 2-Wire AC/DC All Stainless Steel

Stainless Steel Face/Threaded Stainless Steel Barrel

Approximate Dimensions — mm (in.)

Typical Wiring Diagrams

Cable Style

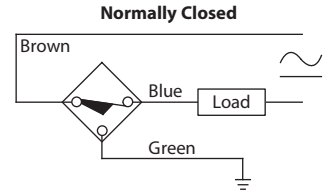
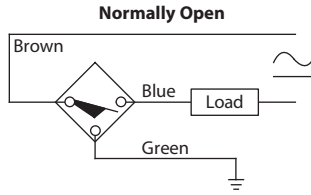
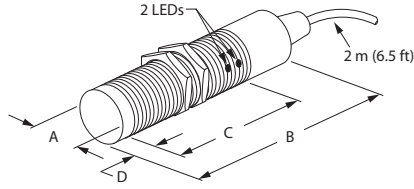

Note: No green wire on 12 mm and on sensors with PVC cable (-A2). Attach housing to ground.
Note: Load can be switched to brown wire.

Thread Size	Shielded	[mm (in.)]			
		A	B	C	D
M12 x 1	Yes	12.0 (0.47)	72.1 (2.84)	38.4 (1.51)	2.5 (0.10)
	No			31.5 (1.24)	9.4 (0.37)
M18 x 1	Yes	18.0 (0.71)	74.7 (2.94)	60.0 (2.36)	2.5 (0.10)
	No			48.2 (1.90)	14.4 (0.56)
M30 x 1.5	Yes	30.0 (1.18)	77.2 (3.04)	61.3 (2.41)	2.5 (0.10)
	No			46.1 (1.81)	17.9 (0.70)

Mini QD Style

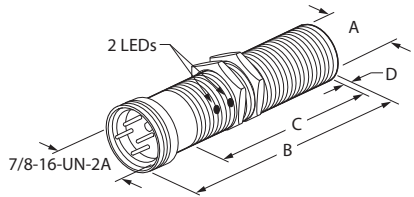

Normally Open or Normally Closed

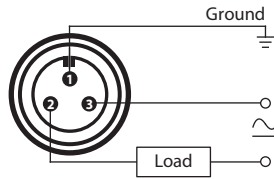

Note: No ground pin on 12 mm. Attach housing to ground.
Note: Load can be switched to pin 3.

Thread Size	Shielded	[mm (in.)]			
		A	B	C	D
M12 x 1	Yes	12.0 (0.47)	85.6 (3.37)	37.8 (1.49)	2.5 (0.10)
	No			31.7 (1.25)	9.4 (0.37)
M18 x 1	Yes	18.0 (0.71)	76.6 (3.02)	54.9 (2.16)	2.5 (0.10)
	No			43.1 (1.70)	14.4 (0.56)
M30 x 1.5	Yes	30.0 (1.18)	86.4 (3.40)	61.3 (2.41)	2.5 (0.10)
	No			46.1 (1.81)	17.9 (0.70)

Micro QD Style

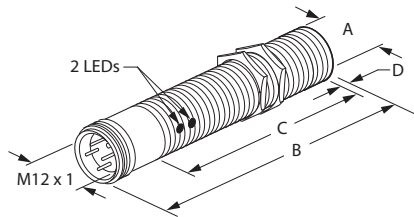

Normally Open or Normally Closed

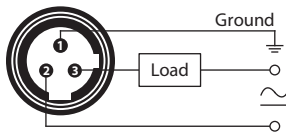

Note: No ground pin on 12 mm. Attach housing to ground.
Note: Load can be switched to pin 2.

Thread Size	Shielded	[mm (in.)]			
		A	B	C	D
M12 x 1	Yes	12.0 (0.47)	83.4 (3.28)	38.4 (1.51)	2.5 (0.10)
	No			31.5 (1.24)	9.4 (0.37)
M18 x 1	Yes	18.0 (0.71)	84.3 (3.32)	60.0 (2.36)	2.5 (0.10)
	No			48.2 (1.90)	14.4 (0.56)
M30 x 1.5	Yes	30.0 (1.18)	85.7 (3.37)	61.3 (2.41)	2.5 (0.10)
	No			46.1 (1.81)	17.9 (0.70)

Tubular Sensors
871TM 2-Wire AC/DC PLC Interfacer
 Stainless Steel Face/Threaded Short Stainless Steel Barrel



871TM AC/DC Cable Style
12, 18, and 30 mm



871TM AC/DC Mini Quick-Disconnect Style
12, 18, and 30 mm



871TM AC/DC Micro Quick-Disconnect Style
12, 18, and 30 mm



871TM AC/DC EAC Micro Quick-Disconnect Style
12 mm



871TM AC/DC ToughLink Cable Style
12, 18, and 30 mm

Specifications

Load Current	2...25 mA
Leakage Current	≤0.9 mA at 24V DC ≤1.7 mA at 20...120V AC/DC ≤2.5 mA at 121...250V AC/DC
Operating Voltage	20...250V AC/DC (standard models) 20...132V AC/DC (high temperature models)
Voltage Drop	≤8V at 25 mA DC ≤10V at 25 mA AC
Repeatability	10% typical
Hysteresis	10% typical
Protection Type	False pulse, transient noise, radio frequency (10V per meter, frequency range 20...1000 MHz) ★
Certifications	UL Listed, CSA Certified, and CE Marked for all applicable directives CCC Certified (select models)
Enclosure Type Rating	NEMA 1, 2, 3, 3R, 4, 4X, 6, 6P, 12, 13; IP67 (IEC 529) all models; 1200 psi (8270 kPa) washdown; ToughLink™ and micro connector versions are also rated IP69K (IEC 529)
Housing Material	Stainless steel face and barrel
Connection Type	Cable: 2 m (6.5 ft) length, A2 - 2-conductor #22 AWG PVC, C2 - 2-conductor #22 AWG ToughLink, H2 - 2-conductor #18 AWG ToughLink; Quick-Disconnect: 3-pin mini style, 3-pin micro style, 4-pin EAC micro style
Indicator LEDs	Red: Output Energized
Operating Temperature [C (F)]	-25...+70 ° (-13...+158 °) (standard models) 0...100 ° (32...212 °) (high temperature models)
Shock	30 g, 11 ms (standard models) 5g, 11 ms (high temperature models)
Vibration	55 Hz, 1 mm amplitude, 3 planes (standard models) 30...120 Hz, 1 mm amplitude, 3 planes (high temperature models)

★ Radio frequency protection not available on high temperature models

Correction Factors

Target Material	Correction Factor
Steel	1.0
Stainless Steel	0.8...1.0
Brass	0.4...0.7
Aluminum	0.4...0.7
Copper	0.2...0.5

Approximate Dimensions—mm (inches)

EAC Micro QD Style

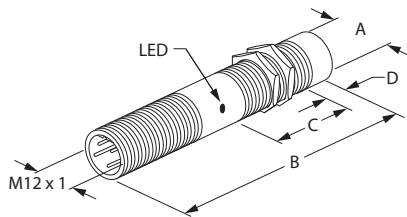

Typical Wiring Diagrams

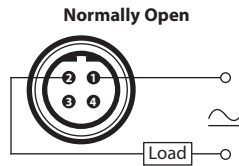

Note: No ground pin. Attach housing to ground.
Note: Load can be switched to pin 2.

Thread Size	Shielded	[mm (in.)]			
		A	B	C	D
M12 x 1	Yes	12.0 (0.47)	61.0 (2.40)	26.4 (1.04)	2.5 (0.10)

Tubular Sensors

871TM 2-Wire AC/DC PLC Interfacer

Stainless Steel Face/Threaded Short Stainless Steel Barrel

Approximate Dimensions—mm (inches)

Typical Wiring Diagrams

Cable Style

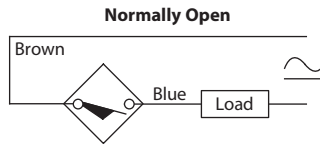
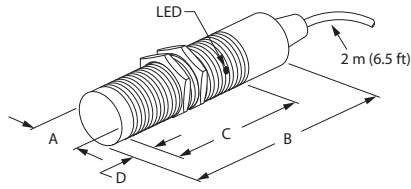

Note: Attach housing to ground.
Note: Load can be switched to brown wire.

Thread Size	Shielded	[mm (in.)]			
		A	B	C	D
M12 x 1	Yes	12.0 (0.47)	49.8 (1.96)	26.4 (1.04)	2.5 (0.10)
	No			19.5 (0.77)	
M18 x 1	Yes	18.0 (0.71)	55.4 (2.18)	41.7 (1.64)	2.5 (0.10)
	No			14.5 (0.57)	
M30 x 1.5	Yes	30.0 (1.18)	57.9 (2.28)	41.9 (1.65)	2.5 (0.10)
	No			39.4 (1.55)	18.0 (0.71)

Mini QD Style

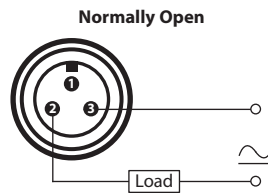
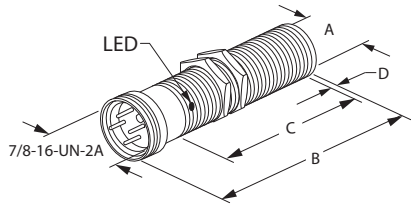

Note: Attach housing to ground.
Note: Load can be switched to pin 3.

Thread Size	Shielded	[mm (in.)]			
		A	B	C	D
M12 x 1	Yes	12.0 (0.47)	63.5 (2.50)	25.4 (1.00)	2.5 (0.10)
	No			18.5 (0.73)	
M18 x 1	Yes	18.0 (0.71)	56.1 (2.21)	35.1 (1.38)	2.5 (0.10)
	No			29.2 (1.15)	14.5 (0.57)
M30 x 1.5	Yes	30.0 (1.18)	68.1 (2.68)	41.9 (1.65)	2.5 (0.10)
	No			39.4 (1.55)	18.0 (0.71)

Micro QD Style

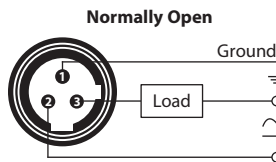
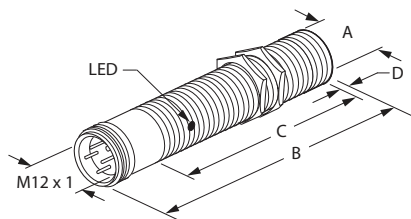

Note: Attach housing to ground.
Note: Load can be switched to pin 2.

Thread Size	Shielded	[mm (in.)]			
		A	B	C	D
M12 x 1	Yes	12.0 (0.47)	61.0 (2.40)	26.4 (1.04)	2.5 (0.10)
	No			19.6 (0.77)	
M18 x 1	Yes	18.0 (0.71)	65.0 (2.56)	41.7 (1.64)	2.5 (0.10)
	No			14.5 (0.57)	
M30 x 1.5	Yes	30.0 (1.18)	66.3 (2.61)	41.9 (1.65)	2.5 (0.10)
	No			39.4 (1.55)	18.0 (0.71)



**871TM Intrinsically Safe
Cable Style**



**871TM Intrinsically Safe
Micro Quick-Disconnect Style**



**871TM Intrinsically Safe
ToughLink Cable Style**

Specifications

Outputs	Normally open
Load Current, Max.	25 mA
Load Current, Min.	2 mA
Leakage Current	≤1.0 mA
Operating Voltage	10...31.5V DC
Voltage Drop	≤8V DC
Repeatability	10% typical
Hysteresis	10% typical
Protection Type	False pulse, transient noise, reverse polarity, short circuit, overload
Certifications	FM Approved and CSA Certified for: -Class I, II, III; Divisions 1, 2; Groups A, B, C, D, E, F, G when used in conjunction with an approved intrinsic safety barrier -Class I, II, III; Division 2; Groups A, B, C, D, E, F, G without intrinsic safety barrier UL Listed for use in non-hazardous locations (See control drawing 75001-437 for approval details and wiring diagrams) ★
Enclosure Type Rating	NEMA 1, 2, 3, 3R, 4, 4X, 6, 6P, 12, 13; IP67 (IEC 529) all models; 1200 psi (8270 kPa) washdown; stainless steel face and barrel; ToughLink™ and micro connector versions are also rated IP69K (IEC 529)
Connection Type	Cable: 2 m (6.5 ft) length, A2 - 2 conductor #22 AWG PVC, C2 - 2 conductor #22 AWG ToughLink, H2 - 2 conductor #18 AWG ToughLink; Quick Disconnect: 4-pin micro style
Indicator LEDs	Red: Output Energized
Operating Temperature [C (F)]	-25...+70 ° (-13...+158 °)
Shock	30 g, 11 ms
Vibration	55 Hz, 1 mm amplitude, 3 planes

★ See [T-11920809].

Correction Factors

Target Material	Correction Factor
Steel	1.0
Stainless Steel	0.9...1.0
Brass	0.3...0.5
Aluminum	0.1...0.4
Aluminum (≤0.02 Thick)	0.9...1.1
Copper	0.4...0.6

Entity Parameters

Sensor			Barrier	
V_{MAX}	31.5V	≥	V_t	
I_{MAX}	130 mA	≥	I_t	
P_{MAX}	1.25 W	≥	P_t	
C_i	0 μf	≤	C_a	
L_i	0 mH	≤	L_a	

IMPORTANT



Operating parameters must be adhered to.

Tubular Sensors

871TM 2-Wire DC Intrinsically Safe

Stainless Steel Face and Barrel

Approximate Dimensions—mm (inches)

Cable Style

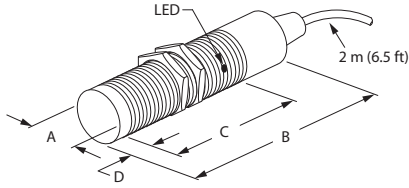

Thread Size	Shielded	[mm (in.)]			
		A	B	C	D
M12 x 1	Yes	12.0 (0.47)	72.1 (2.84)	36.1 (1.42)	2.5 (0.10)
	No			29.2 (1.15)	9.4 (0.37)
M18 x 1	Yes	18.0 (0.71)	74.7 (2.94)	56.3 (1.22)	2.5 (0.10)
	No			44.5 (1.75)	14.4 (0.56)
M30 x 1.5	Yes	30.0 (1.18)	77.2 (3.04)	58.4 (2.30)	2.5 (0.10)
	No			43.2 (1.70)	17.9 (0.70)

Micro QD Style

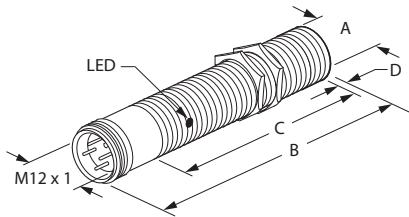

Thread Size	Shielded	[mm (in.)]			
		A	B	C	D
M12 x 1	Yes	12.0 (0.47)	83.3 (3.28)	36.1 (1.42)	2.5 (0.10)
	No			29.2 (1.15)	9.4 (0.37)
M18 x 1	Yes	18.0 (0.71)	84.3 (3.32)	56.3 (2.22)	2.5 (0.10)
	No			44.5 (1.75)	14.4 (0.56)
M30 x 1.5	Yes	30.0 (1.18)	86.1 (3.39)	58.4 (2.30)	2.5 (0.10)
	No			43.2 (1.70)	17.9 (0.70)

Division 1 Installation Wiring Diagrams

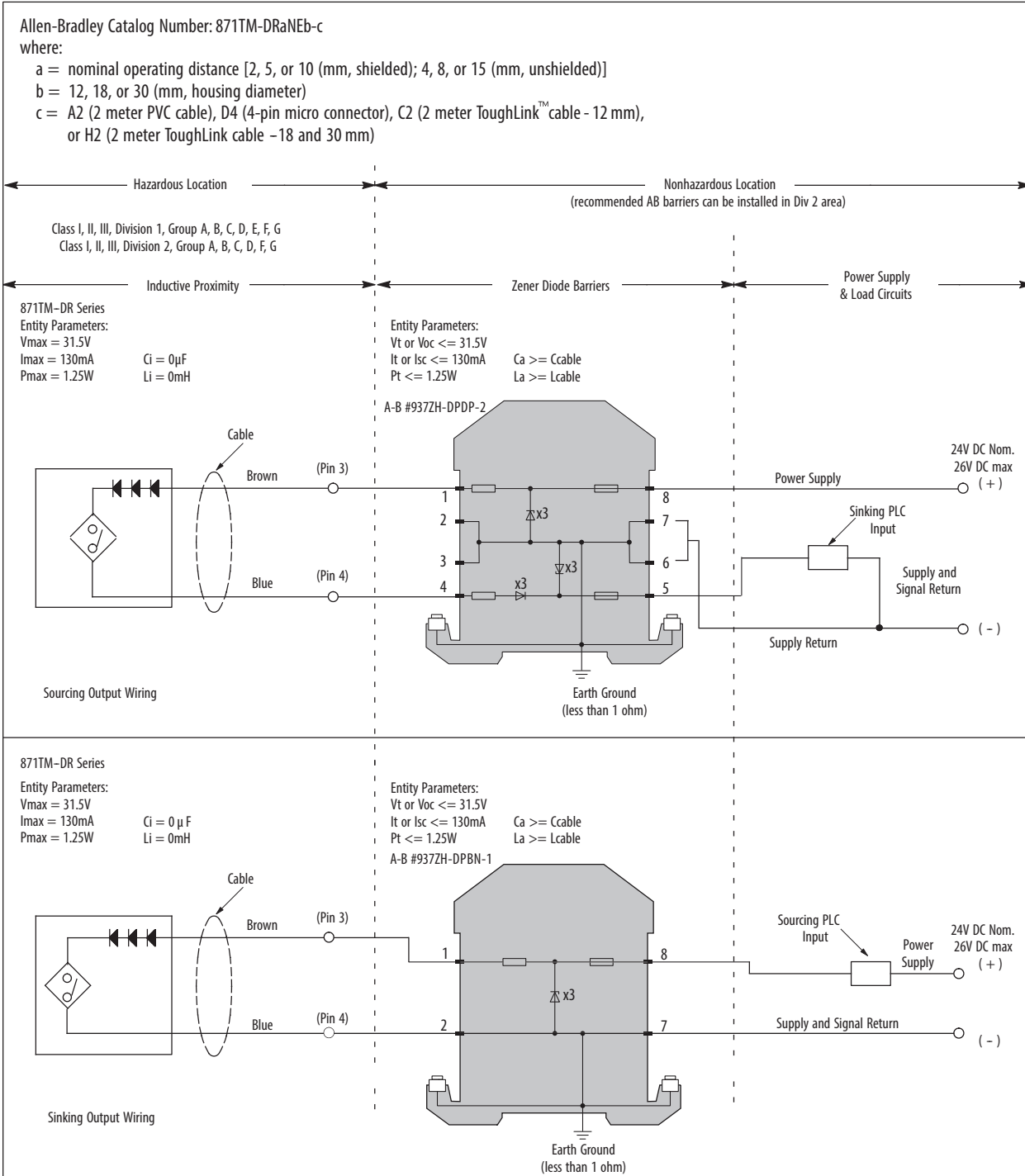

ATTENTION



Operating parameters must be adhered to.

Tubular Sensors

871TM 2-Wire DC Intrinsically Safe

Stainless Steel Face and Barrel

Division 1 Installation Wiring Diagrams (continued)

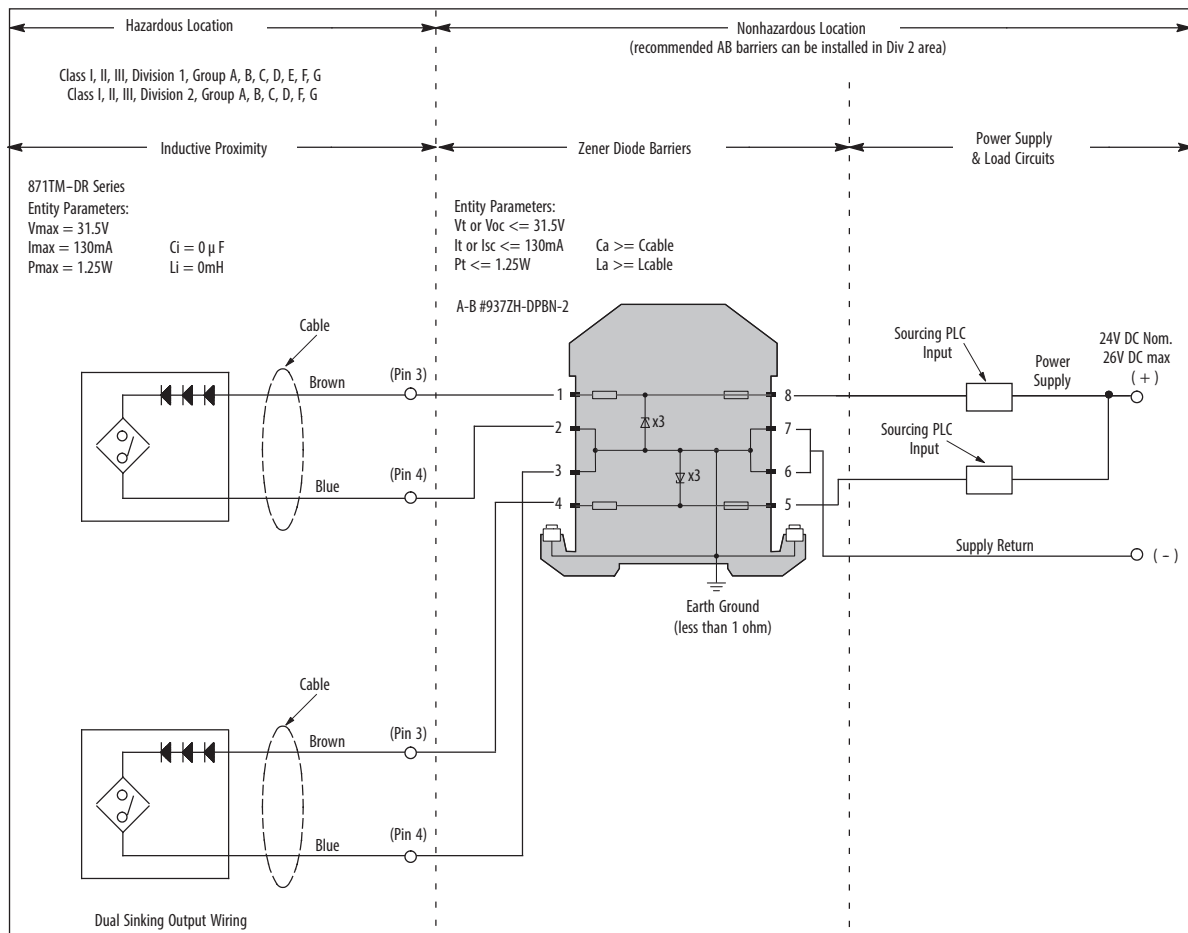

Factory Mutual Installation Notes

- 1 Installation must be in accordance with the National Electrical Code® (NFPA 70, Article 504), ANSI/ISA-RP12.6, and the manufacturer's instructions.
- 2 If the electrical parameters of the cable used are unknown, the following values may be used: Capacitance — 60 pF/ft.; Inductance — 0.20 μH/ft.
- 3 The wiring between each Inductive Proximity Sensor and its corresponding channel of the dual-channel barrier is a separate intrinsically safe circuit. Each of the two separate intrinsically safe circuits shall be in separate cables or shall be separated from each other as specified in NEC 504-30. The supply return conductors may be connected at the barrier's grounding terminal.
- 4 The Barrier bus must be insulated from other grounded metal. Use Power Rail 937A-PR08, 937A-PR20 and Power Feed Module 937A-PSFD.
- 5 The maximum nonhazardous location voltage must not exceed 250V AC or DC.
- 6 Barriers are not required for Division 2 (31.5V DC max.). Division 2 applications must be installed in accordance with the NEC.
- 7 **WARNING:** Substitution of components may impair Intrinsic Safety.
- 8 No revision to drawing without prior FMRC approval.

Canadian Standards Association Installation Notes

- 1 Installation must be in accordance with the Canadian Electrical Code (Part I), ANSI/ISA-RP12.6, and the manufacturer's instructions.
- 2 If the electrical parameters of the cable used are unknown, the following values may be used: Capacitance — 60 pF/ft.; Inductance — 0.20 μH/ft.
- 3 The wiring between each Inductive Proximity Sensor and its corresponding channel of the dual-channel barrier is a separate intrinsically safe circuit. Each of the two separate intrinsically safe circuits shall be in separate cables or shall be separated from each other as specified in CEC. The supply return conductors may be connected at the barrier's grounding terminal.
- 4 The Barrier bus must be insulated from other grounded metal. Use Power Rail 937A-PR08, 937A-PR20 and Power Feed Module 937A-PSFD.
- 5 The maximum nonhazardous location voltage must not exceed 250V AC or DC.
- 6 Barriers are not required for Division 2 (31.5V DC max.). Division 2 applications must be installed in accordance with the CEC.
- 7 In Division 2 applications without barriers observe the following warnings:
WARNING: EXPLOSION HAZARD. Do not disconnect equipment unless power has been switched off or the area is known to be nonhazardous.
- 8 **WARNING:** Substitution of components may impair Intrinsic Safety.
- 9 No revision to drawing without prior CSA approval.

ATTENTION



These parameters must be adhered to.



**871TS DC Micro
 Quick-Disconnect Style
 12, 18 mm**

Specifications

Load Current	≤200 mA
Leakage Current	≤15 μA
Operating Voltage	10...30V DC
Voltage Drop	≤2.0V
Repeatability	≤5%
Hysteresis	≤10% typical
Protection Type	False pulse, transient noise, reverse polarity, short circuit, and overload
Certifications	cULus Listed and CE Marked for all applicable directives
Enclosure Type Rating	NEMA 1, 2, 3, 3R, 4, 4X, 6, 6P, 12, 13; IP67, IP68, and IP69K
Housing Material	Stainless steel 316L, PPS (FDA Certified) plastic face
Connection Type	Quick-Disconnect: 4-pin micro style
LED	Yellow: Output Energized
Operating Temperature [C (F)]	-40...+80 ° (-40...+176 °)
Shock	30 g, 11 ms
Vibration	55 Hz, 1 mm amplitude, 3 planes

Correction Factors

Target Material	Correction Factors
Steel	1.0
Stainless Steel	0.7...0.8
Brass	0.4...0.5
Aluminum	0.3...0.4
Copper	0.2...0.3

Approximate Dimensions [mm (in.)]

Micro QD Style

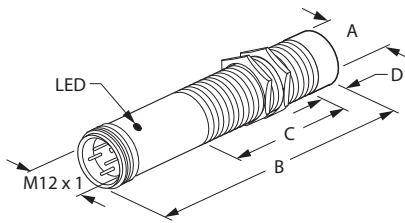

Wiring Diagrams

Complementary Normally Open and Normally Closed

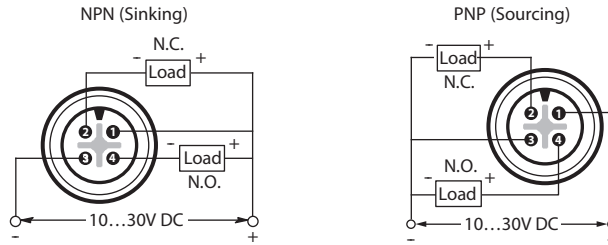

Barrel Type	Thread Size	Shielded	[mm (in.)]			
			A	B	C	D
Threaded	M12 X 1	Yes	12.0 (0.47)	65.0 (2.56)	38.1 (1.50)	—
		No			32.5 (1.28)	6.5 (0.26)
	M18 x 1	Yes	18.0 (0.71)	63.0 (2.48)	34.5 (1.36)	—
		No			26.5 (1.04)	8.0 (0.31)
Smooth	—	Yes	18.0 (0.71)	63.0 (2.48)	—	—
		No			—	8.0 (0.31)

Tubular Sensors
871Z 3-Wire DC Weld Field Immune
 PTFE Face/Threaded PTFE-Coated Brass Barrel



871Z DC Mini
 Quick-Disconnect Style
 18 & 30 mm



871Z DC Micro
 Quick-Disconnect Style
 12, 18, and 30 mm

Specifications

Load Current	≤200 mA
Load Current, Min.	1 mA
Leakage Current	≤10 μA
Operating Voltage	10...30V DC
Voltage Drop	≤2.4V
Repeatability	≤10%
Hysteresis	≤15% typical
Protection Type	False pulse, transient noise, reverse polarity, short circuit, and overload
Weld Field Immunity	20,000 A at 1 inch
Certifications	CE Marked for all applicable directives
Enclosure Type Rating	NEMA 1, 2, 3, 4, 12 and 13; IP67 (IEC529)
Housing Material	PTFE coated brass barrel
Connection Type	Quick-Disconnect: 4-pin mini style, 4-pin micro style
LED	Red: Output Energized
Operating Temperature [C (F)]	-25...+70 ° (-13...+158 °)
Shock	30 g, 11 ms
Vibration	55 Hz, 1 mm amplitude, 3 planes

Correction Factors

Target Material	Correction Factors
Steel	1.0
Stainless Steel	0.7...0.8
Brass	0.4...0.5
Aluminum	0.3...0.4
Copper	0.3...0.4

Approximate Dimensions [mm (in.)]

Mini QD Style

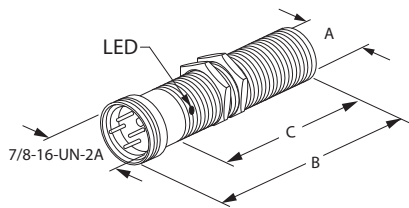

Wiring Diagrams

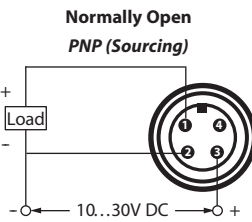

Thread Size	Shielded	[mm (in.)]		
		A	B	C
M18 X 1	Yes	18.0 (0.71)	90 (3.54)	53 (2.09)
M30 X 1.5		30.0 (1.18)	90 (3.54)	56 (2.20)

Micro QD Style

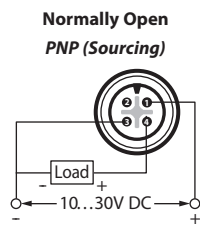
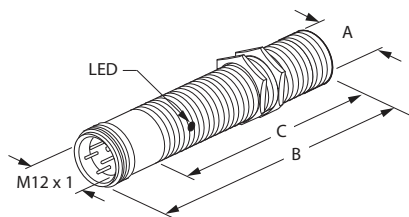

Thread Size	Shielded	[mm (in.)]		
		A	B	C
M12 X 1	Yes	12.0 (0.47)	70.0 (2.76)	50.0 (1.97)
M18 X 1		18.0 (0.71)	80.0 (3.15)	60.0 (2.36)
M30 X 1.5		30.0 (1.18)	80.0 (3.15)	60.0 (2.36)

Tubular Sensors
871Z 2-Wire AC/DC Weld Field Immune
 Thermoset Plastic Face/Threaded PTFE-Coated Brass Barrel



871Z AC/DC Cable Style
18 & 30 mm



871Z AC/DC Mini
Quick-Disconnect Style
12, 18, and 30 mm



871Z AC/DC Micro
Quick-Disconnect Style
12, 18, and 30 mm

Specifications

	12 mm	18 & 30 mm
Load Current	5...200 mA	5...250 mA
Inrush Current (1 cycle)	≤2 A	≤4 A
Leakage Current	≤1.9 mA @ 120V AC	
Operating Voltage	20...250V AC/DC	
Voltage Drop	≤10V @ 5...200 mA	≤10V @ 5...250 mA
Repeatability	≤10% at constant temperature	
Hysteresis	7% typical	
Protection Type	Short circuit (trigger @ 5 A typical), false pulse, reverse polarity (DC output), overload (trigger @ 260 mA typical), and transient noise	Short circuit (trigger @ 8 A typical), false pulse, reverse polarity (DC output), overload (trigger @ 320 mA typical), and transient noise
Weld Field Immunity	20,000 A at 1 inch	
Certifications	UL Listed, CSA Certified, and CE Marked for all applicable directives	
Enclosure Type Rating	NEMA 1, 2, 3, 3R, 4, 4X, 6, 6P, 12, 13; IP67 (IEC529)	
Housing Material	PTFE coated housing	
Connection Type	Cable: 2 m (6.5 ft) length H2 - 3 conductor #18 AWG ToughLink™ Quick-Disconnect: 3-pin micro style, 3-pin mini style	
LED	Red: Output energized Red: Flashing short circuit/overload Green: Power	
Operating Temperature [C (F)]	-25...+70 ° (-13...+158 °)	
Shock	30 g, 11 ms	
Vibration	55 Hz, 1 mm amplitude, 3 planes	

Correction Factors

Target Material	Correction Factors
Steel	1.0
Stainless Steel	0.7...0.8
Brass	0.4...0.5
Aluminum	0.3...0.4
Copper	0.3...0.4

Tubular Sensors

871Z 2-Wire AC/DC Weld Field Immune

Thermoset Plastic Face/Threaded PTFE-Coated Brass Barrel

Approximate Dimensions [mm (in.)]

Wiring Diagrams

Cable Style

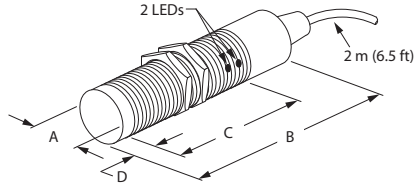

Normally Open



Normally Closed

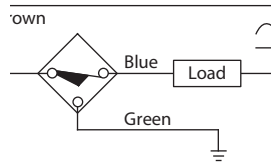

Note: Rear portion of barrel left uncoated for ground contact on 12 mm models.

Thread Size	Shielded	[mm (in.)]			
		A	B	C	D
M18 x 1	Y	18.0 (0.71)	74.68 (2.94)	61.6 (2.43)	0.8 (0.03)
M30 X 1.5	Y	30.0 (1.18)	77.52 (3.05)	64.3 (2.53)	

Mini QD Style

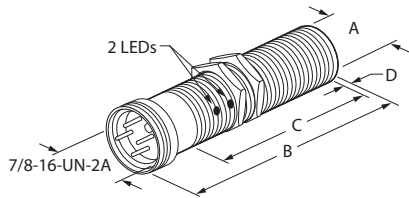

Normally Open or Normally Closed

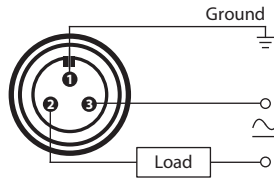

Note: No ground pin on 12 mm. Attach housing to ground.

Note: Load can be switched to pin 3.

Note: Rear portion of barrel left uncoated for ground contact on 12 mm models.

Thread Size	Shielded	[mm (in.)]			
		A	B	C	D
M12 X 1	Y	12.0 (0.47)	93.45 (3.68)	46.2 (1.82)	0.8 (0.03)
	N			40.7 (1.52)	8.1 (0.32)
M18 X 1	Y	18.0 (0.71)	75.82 (2.99)	57.28 (2.26)	0.8 (0.03)
M30 X 1.5	Y	30.0 (1.18)	86.66 (3.41)	64.3 (2.53)	0.8 (0.03)

Micro QD Style

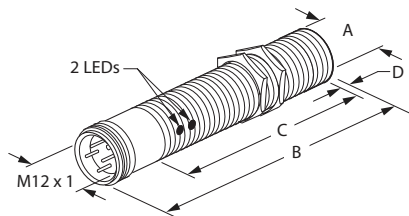

Normally Open or Normally Closed

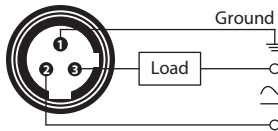

Note: No ground pin on 12 mm. Attach housing to ground.

Note: Load can be switched to pin 2.

Note: Rear portion of barrel left uncoated for ground contact on 12 mm models.

Thread Size	Shielded	[mm (in.)]			
		A	B (max)	C (min)	D (max)
M12 x 1	Y	12.0 (0.47)	90.1 (3.55)	46.7 (1.85)	0.8 (0.03)
	N			39.7 (1.56)	8.10 (0.32)
M18 x 1	Y	18.0 (0.71)	83.5 (3.29)	61.6 (2.43)	0.8 (0.03)
M30 X 1.5	Y	30.0 (1.18)	86.0 (3.38)	64.3 (2.53)	0.8 (0.03)

Tubular Sensors

871ZT 3-Wire DC Weld Field Immune/Equal Sensing

PTFE Face/Threaded PTFE-Coated Brass Barrel



**871ZT DC Micro
Quick-Disconnect Style
12, 18, and 30 mm**

Specifications

Load Current, Max.	200 mA
Load Current, Min.	1 mA
Leakage Current	<0.08 mA
Operating Voltage	10...30V DC
Voltage Drop	≤2.5V
Repeatability	≤5% typical
Hysteresis	≤10% typical
Protection Type	False pulse, transient noise, reverse polarity, short circuit, and overload
Weld Field Immunity	Up to 1260 Gauss (M5)
Certifications	UL Listed and CE Marked for all applicable directives
Enclosure Type Rating	IP67 (IEC 529)
Housing Material	PTFE coated brass barrel
Connection Type	Quick-Disconnect: 4-pin micro style
LED	360° LED visibility; Orange: Target Present
Operating Temperature [C (F)]	-25...+70 ° (-13...+158 °)
Shock	30 g, 11 ms
Vibration	55 Hz, 1 mm amplitude, 3 planes

Correction Factors

Target Material	Correction Factors
Steel	1.0
Stainless Steel	0.9...1.1
Brass	0.9...1.1
Aluminum	0.9...1.1
Copper	0.9...1.1

Tubular Sensors
871ZT 3-Wire DC Weld Field Immune/Equal Sensing
 PTFE Face/Threaded PTFE-Coated Brass Barrel

Approximate Dimensions [mm (in.)]

Wiring Diagrams

Micro QD Style

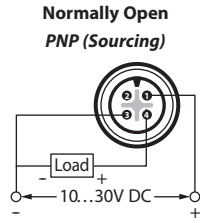
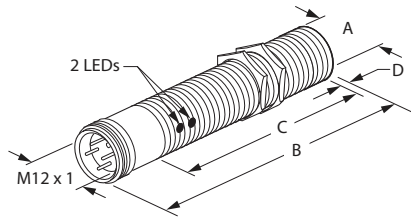

Thread Size	Shielded	[mm (in.)]			
		A	B	C	D
M12 x 1	Yes	12.0 (0.47)	65 (2.56)	50 (1.97)	—
	No			40 (1.58)	10 (0.39)
M18 x 1	Yes	18.0 (0.71)		50 (1.97)	—
	No			40.5 (1.59)	10 (0.39)
M30 X 1.5	Yes	30.0 (1.18)		50.5 (1.99)	—
	No			37.5 (1.48)	13 (0.51)



DC Micro Quick-Disconnect Style
8, 12, 18, and 30 mm



DC Pico Quick-Disconnect Style
6.5, 8, 12, and 18 mm



DC Mini Quick-Disconnect Style
18 & 30 mm



DC Cable Style
6.5, 8, 12, 18, and 30 mm



Pigtail Cable with Integral Micro QD Connector
8, 12, 18, and 30 mm

Specifications

Load Current	≤200 mA
Leakage Current	≤10 μA
Operating Voltage	10...30V DC
Voltage Drop	≤1.8V
Repeatability	≤5%
Hysteresis	≤10% typical
Protection Type	False pulse on power, transient noise, reverse polarity, short circuit, and overload
Certifications	cULus Listed (8, 12, 18, and 30 mm models only) and CE Marked (all models) for all applicable directives
Enclosure Type Rating	NEMA 1, 2, 3, 4, 6P, 12, 13, IP 67 (IEC 529)
Housing Material	Nickel-plated brass barrel, plastic face (PBT) Optional stainless steel 304 barrel, plastic face (PBT)
Connections	Cable (PVC/PUR): 2 m (6.5 ft), 5 m (16.4 ft), 10 m (32.8 ft) length, 4.4 mm (0.175 in.) diameter; 3-conductor #26 AWG PVC or PUR; Cable (Pigtail): 0.2 m (0.7 ft), 0.5 m (1.6 ft), 1 m (3.3 ft) length, Integral 4-pin micro QD Quick-Disconnect: 4-pin mini, 4-pin micro or 3-pin pico style
LED	Amber: output energized, 360° visibility
Operating Temperature [C (F)]	-25...+70 ° (-13...+158 °)
Shock	30 g, 11 ms half-sine
Vibration	55 Hz, 1 mm amplitude, 3 planes

Correction Factors

Target Material	Correction Factors
Steel	1.0
Stainless Steel	0.7...0.8
Brass	0.4...0.5
Aluminum	0.3...0.4
Copper	0.2...0.3

Tubular Sensors

872C WorldProx™ 3-Wire DC

Plastic Face/Threaded Nickel-Plated Brass or Stainless Steel Barrel

Approximate Dimensions [mm (in.)]

Wiring Diagrams

Cable Style

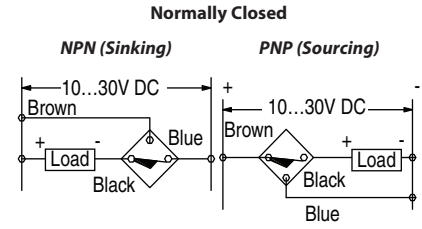
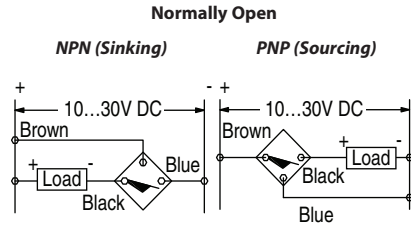
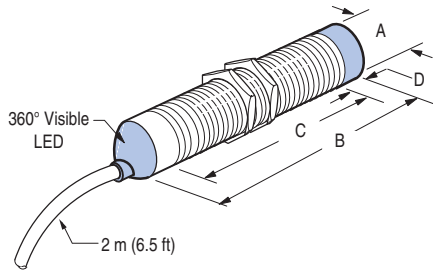

Thread Size	Barrel Type	Smooth Diameter	Shielded	[mm (in.)]			
				A	B (max)	C (min)	D (max)
—	Nickel-plated brass	6.5	Yes	6.50 (0.26)	33.0 (1.30)	—	—
M8 x 1	Nickel-plated brass and stainless steel	—	Yes	8.00 (0.31)	32.8 (1.29)	30.2 (1.19)	—
			No		36.8 (1.45)		
M12 x 1		Yes	12.0 (0.47)	50.8 (2.00)	46.7 (1.84)	—	
			No	58.9 (2.32)			8.10 (0.32)
M18 x 1	Yes	18.0 (0.71)	50.8 (2.00)	46.7 (1.84)	—		
		No	63.0 (2.48)			12.2 (0.48)	
M30 x 1	Yes	30.0 (1.18)	50.8 (2.00)	47.7 (1.88)	—		
		No	63.0 (2.48)			12.2 (0.48)	

Mini QD Style

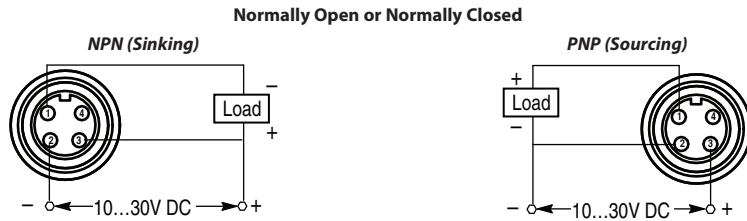
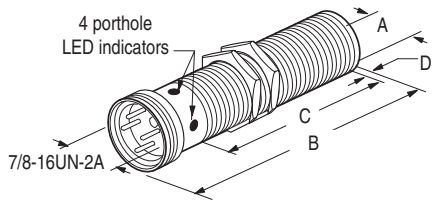

Thread Size	Barrel Type	Shielded	[mm (in.)]			
			A	B (max)	C (min)	D (max)
M18 x 1	Nickel-plated brass and stainless steel	Yes	18.0 (0.71)	63.5 (2.50)	35.1 (1.38)	—
		No		75.7 (2.98)		
M30 X 1.5	Nickel-plated brass	Yes	30.0 (1.18)	63.5 (2.50)	38.1 (1.50)	—
		No		75.7 (2.98)		
	Stainless steel	Yes		64.3 (2.53)	47.8 (1.88)	—
		No		76.5 (3.01)		

Approximate Dimensions [mm (in.)]

Wiring Diagrams

Micro QD Style

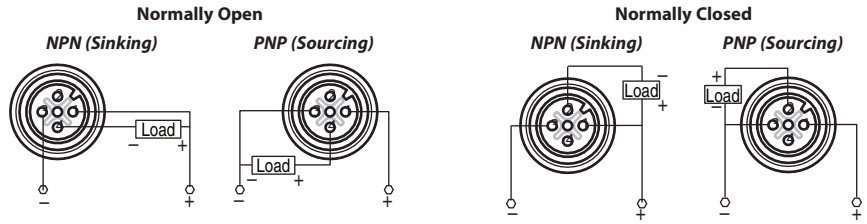
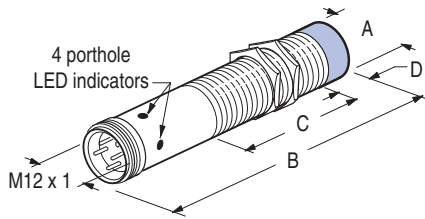

Thread Size	Barrel Type	Shielded	[mm (in.)]			
			A	B (max)	C (min)	D (max)
M8 x 1	Nickel-plated brass and stainless steel	Yes	8.00 (0.31)	58.7 (2.31)	27.7 (1.09)	—
		No		62.7 (2.47)		4.00 (0.16)
M12 x 1		Yes	12.0 (0.47)	64.3 (2.53)	38.1 (1.50)	—
		No		72.4 (2.85)		8.10 (0.32)
M18 x 1		Yes	18.0 (0.71)	64.3 (2.53)	38.1 (1.50)	—
		No		76.5 (3.01)		12.2 (0.48)
M30 X 1.5		Yes	30.0 (1.18)	64.3 (2.53)	47.75 (1.88)	—
		No		76.5 (3.01)		12.2 (0.48)

Pico QD Style

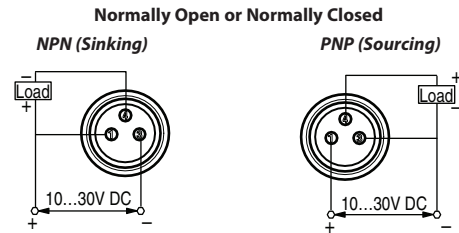
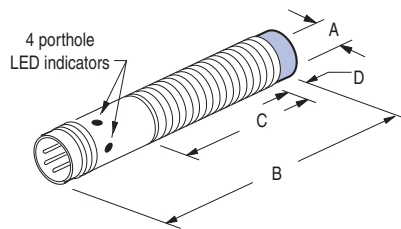

Thread Size	Barrel Type	Smooth Diameter	Shielded	[mm (in.)]			
				A	B (max)	C (min)	D (max)
—	Nickel-plated brass	6.5	Yes	6.50 (0.26)	49.0 (1.93)	—	—
M8 x 1	Nickel-plated brass and stainless steel	—	Yes	8.00 (0.31)	49.5 (1.95)	34.0 (1.34)	—
			No		53.6 (2.11)		4.10 (0.16)
M12 x 1		Yes	12.0 (0.47)	63.5 (2.50)	47.5 (1.87)	—	
		No		71.6 (2.82)		8.10 (0.32)	
M18 x 1		Yes	18.0 (0.71)	63.5 (2.50)	47.5 (1.87)	—	
		No		75.7 (2.98)		12.2 (0.48)	

Tubular Sensors

872C WorldProx™ Short Barrel 3-Wire DC

Plastic Face/Threaded Nickel-Plated Brass or Stainless Steel Barrel



DC Micro Quick-Disconnect Style
8, 12, 18, and 30 mm



DC Pico Quick-Disconnect Style
8, 12, and 18 mm



DC Mini Quick-Disconnect Style
18 & 30 mm



DC Cable Style
8, 12, 18, and 30 mm



Pigtail Cable with Integral Micro QD Connector
8, 12, 18, and 30 mm

Specifications

Load Current	≤200 mA
Leakage Current	≤10 μA
Operating Voltage	10...30V DC
Voltage Drop	≤1.8V
Repeatability	≤5%
Hysteresis	≤10% typical
Protection Type	False pulse on power, transient noise, reverse polarity, short circuit, and overload
Certifications	cULus Listed and CE Marked for all applicable directives
Enclosure Type Rating	NEMA 1, 2, 3, 4, 6P, 12, 13, IP 67 (IEC 529)
Housing Material	Nickel-plated brass barrel, plastic face (PBT); Optional stainless steel 304 barrel, plastic face (PBT)
Connections	Cable (PVC/PUR): 2 m (6.5 ft), 5 m (16.4 ft), 10 m (32.8 ft) length, 4.4 mm (0.175 in.) diameter; 3-conductor #26 AWG PVC or PUR; Cable (Pigtail): 0.2 m (0.7 ft), 0.5 m (1.6 ft), 1 m (3.3 ft) length, Integral 4-pin micro QD Quick-Disconnect: 4-pin mini, 4-pin micro or 3-pin pico style
Status Indicator	Amber: Output energized, 360° visibility
Operating Temperature [C (F)]	-25...+70 ° (-13...+158 °)
Shock	30 g, 11 ms
Vibration	55 Hz, 1 mm amplitude, 3 planes

Correction Factors

Target Material	Correction Factors
Steel	1.0
Stainless Steel	0.7...0.8
Brass	0.4...0.5
Aluminum	0.3...0.4
Copper	0.2...0.3

Tubular Sensors
872C WorldProx™ Short Barrel 3-Wire DC
 Plastic Face/Threaded Nickel-Plated Brass or Stainless Steel Barrel

Approximate Dimensions [mm (in.)]

Wiring Diagrams

Cable Style

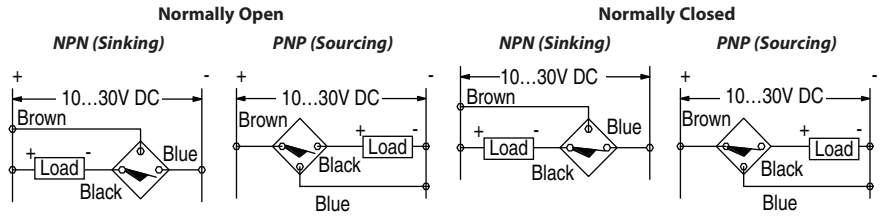
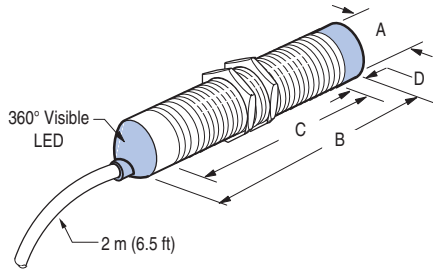

Thread Size	Barrel Type	Shielded	[mm (in.)]					
			A	B (max)	C (min)	D (max)		
M8 x 1	Nickel-plated brass and stainless steel	Yes	8.00 (0.31)	26.7 (1.05)	24.1 (0.95)	—		
		No		30.7 (1.21)		4.10 (0.16)		
M12 x 1		Yes	12.0 (0.47)	34.8 (1.37)	31.8 (1.25)	—		
		No		42.9 (1.69)		8.10 (0.32)		
M18 x 1		Yes	18.0 (0.71)	34.8 (1.37)		—	—	
		No		47.0 (1.85)			12.2 (0.48)	
M30 x 1		Nickel-plated brass	Yes	30.0 (1.18)		34.8 (1.37)	—	—
			No			47.0 (1.85)		12.2 (0.48)
	Stainless steel	Yes	37.3 (1.47)			34.3 (1.35)	—	
		No	49.5 (1.95)				12.2 (0.48)	

Mini QD Style

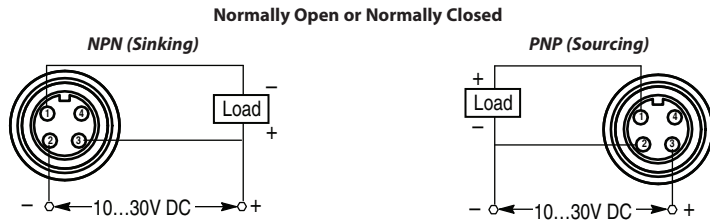
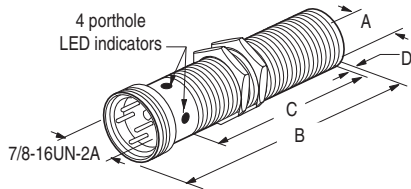

Thread Size	Barrel Type	Shielded	[mm (in.)]				
			A	B (max)	C (min)	D (max)	
M18 x 1	Nickel-plated brass and stainless steel	Yes	18.0 (0.71)	47.5 (1.87)	24.2 (0.95)	—	
		No		59.7 (2.35)		12.2 (0.48)	
M30 X 1.5		Nickel-plated brass	Yes	30.0 (1.18)	47.5 (1.87)	26.4 (1.04)	—
			No		59.7 (2.35)		12.2 (0.48)
Stainless steel	Yes	50.8 (2.00)	34.3 (1.35)		—		
	No	63.0 (2.48)			12.2 (0.48)		

Tubular Sensors

872C WorldProx™ Short Barrel 3-Wire DC

Plastic Face/Threaded Nickel-Plated Brass or Stainless Steel Barrel

Approximate Dimensions [mm (in.)]

Wiring Diagrams

Micro QD Style

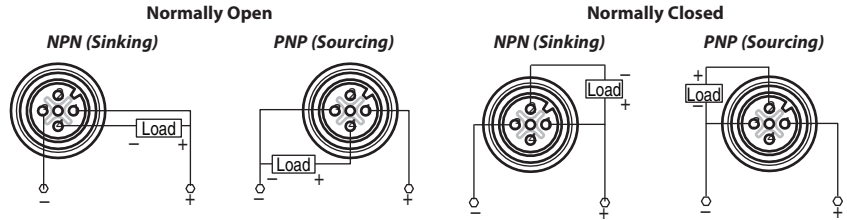
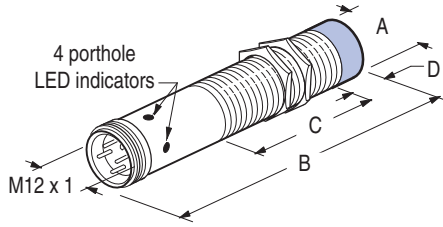

Thread Size	Barrel Type	Shielded	[mm (in.)]			
			A	B (max)	C (min)	D (max)
M8 x 1	Nickel-plated brass and stainless steel	Yes	8.00 (0.31)	45.2 (1.78)	20.1 (0.79)	—
		No		49.3 (1.94)		4.10 (0.16)
M12 x 1		Yes	12.0 (0.47)	48.3 (1.90)	27.4 (1.08)	—
		No		56.4 (2.22)		8.10 (0.32)
M18 x 1	Nickel-plated brass	Yes	18.0 (0.71)	49.5 (1.95)	26.4 (1.04)	—
		No		61.7 (2.43)		12.2 (0.48)
	Stainless steel	Yes		48.3 (1.90)	31.8 (1.25)	—
		No		60.5 (2.38)		12.2 (0.48)
M30 X 1.5	Nickel-plated brass and stainless steel	Yes	30.0 (1.18)	50.8 (2.00)	31.8 (1.25)	—
		No		63.2 (2.49)		12.2 (0.48)

Pico QD Style

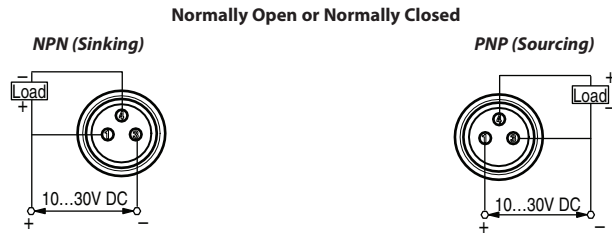
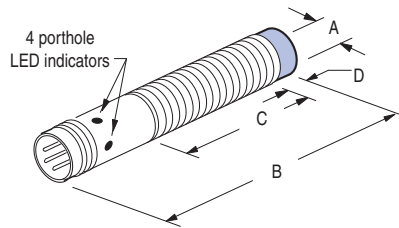

Thread Size	Barrel Type	Shielded	[mm (in.)]			
			A	B (max)	C (min)	D (max)
M8 x 1	Nickel-plated brass and stainless steel	Yes	8.00 (0.31)	44.5 (1.75)	29.0 (1.14)	—
		No		48.5 (1.91)		4.10 (0.16)
M12 x 1		Yes	12.0 (0.47)	45.2 (1.78)	29.2 (1.15)	—
		No		53.3 (2.10)		8.10 (0.32)
M18 x 1	Nickel-plated brass and stainless steel	Yes	18.0 (0.71)	47.5 (1.87)	31.5 (1.24)	—
		No		59.7 (2.35)		12.2 (0.48)

Tubular Sensors

872C WorldProx™ Extended Sensing 3-Wire DC

Plastic Face/Threaded Nickel-Plated Brass or Stainless Steel Barrel



DC Micro Quick-Disconnect Style
8, 12, 18, and 30 mm



DC Pico Quick-Disconnect Style
6.5, 8, 12, and 18 mm



DC Mini Quick-Disconnect Style
18 & 30 mm



DC Cable Style
6.5, 8, 12, 18, and 30 mm



Pigtail Cable with Integral Micro QD Connector
8, 12, 18, and 30 mm

Specifications

Load Current	≤200 mA
Leakage Current	≤10 μA
Operating Voltage	10...30V DC
Voltage Drop	≤1.8V
Repeatability	≤5%
Hysteresis	≤10% typical
Protection Type	False pulse on power, transient noise, reverse polarity, short circuit, and overload
Certifications	cULus Listed and CE Marked for all applicable directives
Enclosure Type Rating	NEMA 1, 2, 3, 4, 6P, 12, 13, IP 67 (IEC 529)
Housing Material	Nickel-plated brass barrel, plastic face (PBT) Optional stainless steel 304 barrel, plastic face (PBT)
Connections	Cable (PVC/PUR): 2 m (6.5 ft), 5 m (16.4 ft), 10 m (32.8 ft) length, 4.4 mm (0.175 in.) diameter; 3-conductor #26 AWG PVC or PUR; Cable (Pigtail): 0.2 m (0.7 ft), 0.5 m (1.6 ft), 1 m (3.3 ft) length, Integral 4-pin micro QD Quick-Disconnect: 4-pin mini, 4-pin micro or 3-pin pico style
LED	Amber: output energized, 360° visibility
Operating Temperature [C (F)], Min	-25...+70 ° (-13...+158 °)
Shock	30 g, 11 ms half-sine
Vibration	55 Hz, 1 mm amplitude, 3 planes

Correction Factors

Target Material	Correction Factors
Steel	1.0
Stainless Steel	0.7...0.8
Brass	0.5...0.6
Aluminum	0.5...0.6
Copper	0.4...0.5

Tubular Sensors

872C WorldProx™ Extended Sensing 3-Wire DC

Plastic Face/Threaded Nickel-Plated Brass or Stainless Steel Barrel

Approximate Dimensions [mm (in.)]

Wiring Diagrams

Cable Style

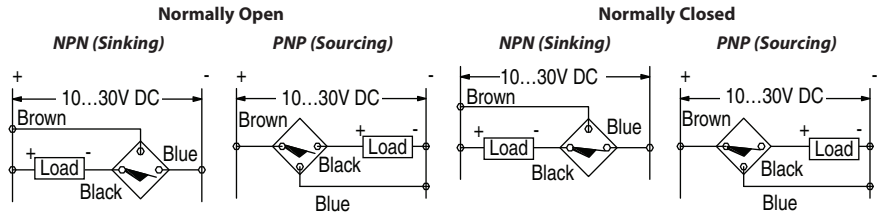
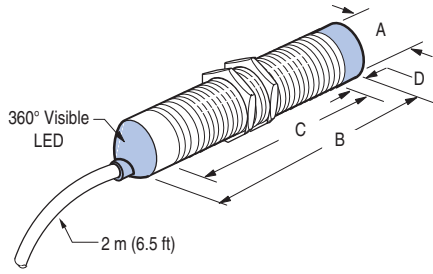

Thread Size	Barrel Type	Shielded	[mm (in.)]			
			A	B (max)	C (min)	D (max)
M8 x 1	Nickel-plated brass and stainless steel	Yes	8.00 (0.31)	32.8 (1.29)	30.2 (1.19)	—
		No		36.8 (1.45)		4.10 (0.16)
M12 x 1		Yes	12.0 (0.47)	50.8 (2.00)	46.7 (1.84)	—
		No		58.9 (2.32)		8.10 (0.32)
M18 x 1		Yes	18.0 (0.71)	50.8 (2.00)	46.7 (1.84)	—
		No		63.0 (2.48)		12.2 (0.48)
M30 x 1		Yes	30.0 (1.18)	50.8 (2.00)	47.7 (1.88)	—
		No		63.0 (2.48)		12.2 (0.48)

Mini QD Style

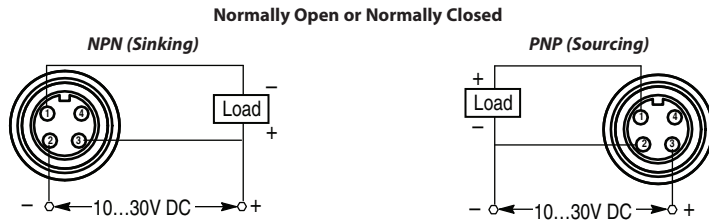
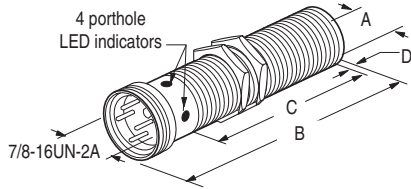

Thread Size	Barrel Type	Shielded	[mm (in.)]				
			A	B (max)	C (min)	D (max)	
M18 x 1	Nickel-plated brass and stainless steel	Yes	18.0 (0.71)	63.5 (2.50)	35.1 (1.38)	—	
		No		75.7 (2.98)		12.2 (0.48)	
M30 X 1.5		Nickel-plated brass	Yes	30.0 (1.18)	63.5 (2.50)	38.1 (1.50)	—
		No	75.7 (2.98)		12.2 (0.48)		
Stainless steel	Yes	64.3 (2.53)	47.8 (1.88)		—		
	No	76.5 (3.01)			12.2 (0.48)		

Tubular Sensors
872C WorldProx™ Extended Sensing 3-Wire DC
 Plastic Face/Threaded Nickel-Plated Brass or Stainless Steel Barrel

Approximate Dimensions [mm (in.)]

Wiring Diagrams

Micro QD Style

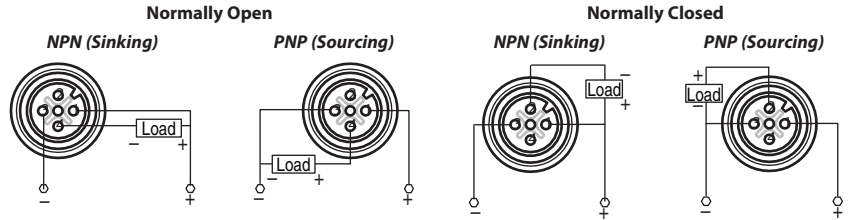
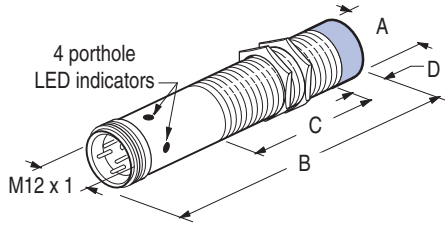

Thread Size	Barrel Type	Shielded	[mm (in.)]			
			A	B (max)	C (min)	D (max)
M8 x 1	Nickel-plated brass and stainless steel	Yes	8.00 (0.31)	58.7 (2.31)	27.7 (1.09)	—
		No		62.7 (2.47)		4.00 (0.16)
M12 x 1		Yes	12.0 (0.47)	64.3 (2.53)	38.1 (1.50)	—
		No		72.4 (2.85)		8.10 (0.32)
M18 x 1		Yes	18.0 (0.71)	64.3 (2.53)	38.1 (1.50)	—
		No		76.5 (3.01)		12.2 (0.48)
M30 X 1.5		Yes	30.0 (1.18)	64.3 (2.53)	47.75 (1.88)	—
		No		76.5 (3.01)		12.2 (0.48)

Pico QD Style

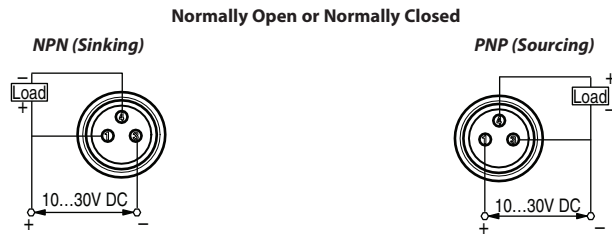
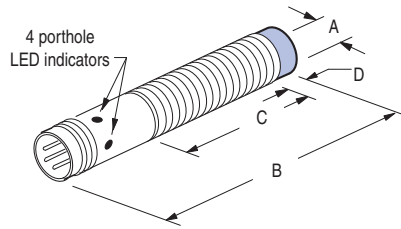

Thread Size	Barrel Type	Shielded	[mm (in.)]			
			A	B (max)	C (min)	D (max)
M8 x 1	Nickel-plated brass and stainless steel	Yes	8.00 (0.31)	49.5 (1.95)	34.0 (1.34)	—
		No		53.6 (2.11)		4.10 (0.16)
M12 x 1		Yes	12.0 (0.47)	63.5 (2.50)	47.5 (1.87)	—
		No		71.6 (2.82)		8.10 (0.32)
M18 x 1		Yes	18.0 (0.71)	63.5 (2.50)	47.5 (1.87)	—
		No		75.7 (2.98)		12.2 (0.48)

Tubular Sensors

872C WorldProx™ Short Barrel Extended Sensing 3-Wire DC

Plastic Face/Threaded Nickel-Plated Brass or Stainless Steel Barrel



DC Micro Quick-Disconnect Style
8, 12, 18, and 30 mm



DC Pico Quick-Disconnect Style
8, 12, and 18 mm



DC Mini Quick-Disconnect Style
18 & 30 mm



DC Cable Style
8, 12, 18, and 30 mm



Pigtail Cable with Integral Micro QD Connector
8, 12, 18, and 30 mm

Specifications

Load Current	≤200 mA
Leakage Current	≤10 μA
Operating Voltage	10...30V DC
Voltage Drop	≤1.8V
Repeatability	≤5%
Hysteresis	≤10% typical
Protection Type	False pulse on power, transient noise, reverse polarity, short circuit, and overload
Certifications	cULus Listed and CE Marked for all applicable directives
Enclosure Type Rating	NEMA 1, 2, 3, 4, 6P, 12, 13, IP 67 (IEC 529)
Housing Material	Nickel-plated brass barrel, plastic face (PBT); Optional stainless steel 304 barrel, plastic face (PBT)
Connections	Cable (PVC/PUR): 2 m (6.5 ft), 5 m (16.4 ft), 10 m (32.8 ft) length, 4.4 mm (0.175 in.) diameter; 3-conductor #26 AWG PVC or PUR; Cable (Pigtail): 0.2 m (0.7 ft), 0.5 m (1.6 ft), 1 m (3.3 ft) length, Integral 4-pin micro QD Quick-Disconnect: 4-pin mini, 4-pin micro or 3-pin pico style
Status Indicator	Amber: Output energized, 360° visibility
Operating Temperature [C (F)], Min	-25...+70 ° (-13...+158 °)
Shock	30 g, 11 ms
Vibration	55 Hz, 1 mm amplitude, 3 planes

Correction Factors

Target Material	Correction Factors
Steel	1.0
Stainless Steel	0.7...0.8
Brass	0.4...0.5
Aluminum	0.3...0.4
Copper	0.2...0.3

Tubular Sensors

872C WorldProx™ Short Barrel Extended Sensing 3-Wire DC

Plastic Face/Threaded Nickel-Plated Brass or Stainless Steel Barrel

Approximate Dimensions [mm (in.)]

Wiring Diagrams

Cable Style

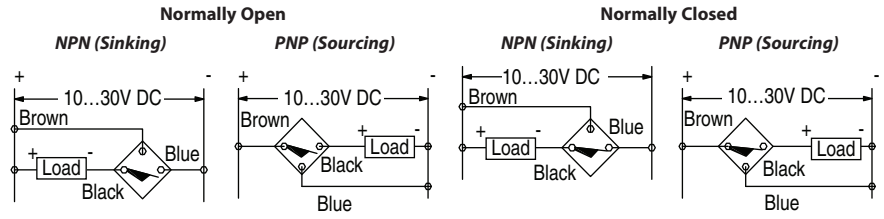
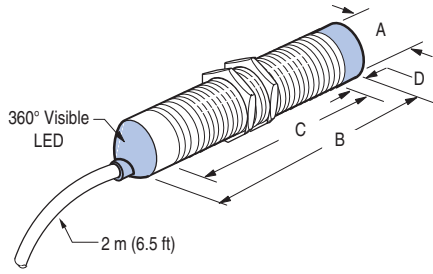

Thread Size	Barrel Type	Shielded	[mm (in.)]				
			A	B (max)	C (min)	D (max)	
M8 x 1	Nickel-plated brass and stainless steel	Yes	8.00 (0.31)	26.7 (1.05)	24.1 (0.95)	—	
		No		30.7 (1.21)		4.10 (0.16)	
M12 x 1		Yes	12.0 (0.47)	34.8 (1.37)	31.8 (1.25)	—	
		No		42.9 (1.69)		8.10 (0.32)	
M18 x 1		Yes	18.0 (0.71)	34.8 (1.37)		—	—
		No		47.0 (1.85)			12.2 (0.48)
M30 x 1	Nickel-plated brass	Yes	30.0 (1.18)	34.8 (1.37)		—	—
		No		47.0 (1.85)			12.2 (0.48)
	Stainless steel	Yes		37.3 (1.47)	34.3 (1.35)	—	
		No		49.5 (1.95)		12.2 (0.48)	

Mini QD Style

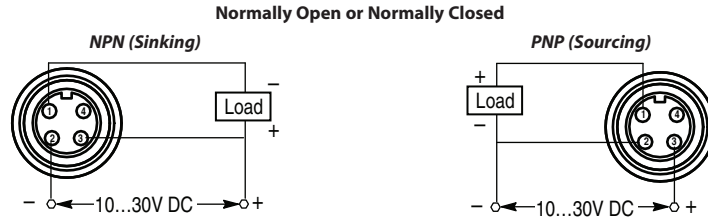
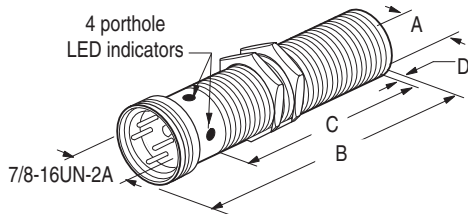

Thread Size	Barrel Type	Shielded	[mm (in.)]			
			A	B (max)	C (min)	D (max)
M18 x 1	Nickel-plated brass and stainless steel	Yes	18.0 (0.71)	47.5 (1.87)	24.2 (0.95)	—
		No		59.7 (2.35)		12.2 (0.48)
M30 X 1.5	Nickel-plated brass	Yes	30.0 (1.18)	47.5 (1.87)	26.4 (1.04)	—
		No		59.7 (2.35)		12.2 (0.48)
	Stainless steel	Yes		50.8 (2.00)	34.3 (1.35)	—
		No		63.0 (2.48)		12.2 (0.48)

Tubular Sensors

872C WorldProx™ Short Barrel Extended Sensing 3-Wire DC

Plastic Face/Threaded Nickel-Plated Brass or Stainless Steel Barrel

Approximate Dimensions [mm (in.)]

Wiring Diagrams

Micro QD Style

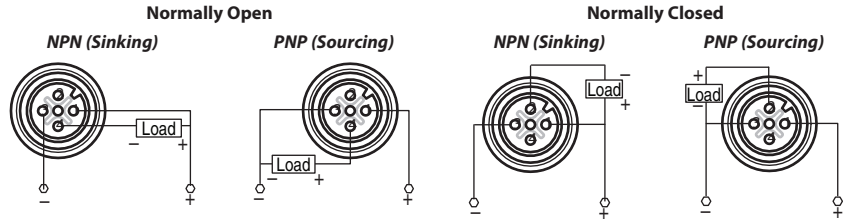
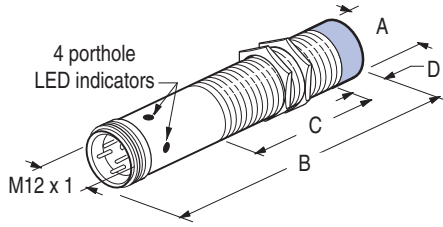

Thread Size	Barrel Type	Shielded	[mm (in.)]			
			A	B (max)	C (min)	D (max)
M8 x 1	Nickel-plated brass and stainless steel	Yes	8.00 (0.31)	45.2 (1.78)	20.1 (0.79)	—
		No		49.3 (1.94)		4.10 (0.16)
M12 x 1		Yes	12.0 (0.47)	48.3 (1.90)	27.4 (1.08)	—
		No		56.4 (2.22)		8.10 (0.32)
M18 x 1	Nickel-plated brass	Yes	18.0 (0.71)	49.5 (1.95)	26.4 (1.04)	—
		No		61.7 (2.43)		12.2 (0.48)
	Stainless steel	Yes		48.3 (1.90)	31.8 (1.25)	—
		No		60.5 (2.38)		12.2 (0.48)
M30 X 1.5	Nickel-plated brass and stainless steel	Yes	30.0 (1.18)	50.8 (2.00)	31.8 (1.25)	—
		No		63.2 (2.49)		12.2 (0.48)

Pico QD Style

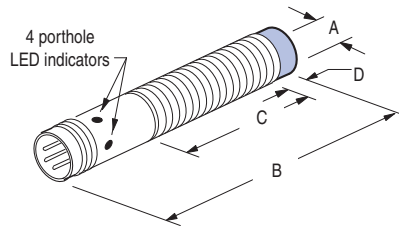

Normally Open or Normally Closed



Thread Size	Barrel Type	Shielded	[mm (in.)]			
			A	B (max)	C (min)	D (max)
M8 x 1	Nickel-plated brass and stainless steel	Yes	8.00 (0.31)	44.5 (1.75)	29.0 (1.14)	—
		No		48.5 (1.91)		4.10 (0.16)
M12 x 1		Yes	12.0 (0.47)	45.2 (1.78)	29.2 (1.15)	—
		No		53.3 (2.10)		8.10 (0.32)
M18 x 1	Nickel-plated brass and stainless steel	Yes	18.0 (0.71)	47.5 (1.87)	31.5 (1.24)	—
		No		59.7 (2.35)		12.2 (0.48)



872CP DC Cable Style
 12, 18, and 30 mm



872CP DC Micro Quick-Disconnect Style
 12, 18, and 30 mm



Pigtail Cable with Integral Micro QD Connector
 12, 18, and 30 mm

Specifications

Load Current	≤200 mA
Leakage Current	≤10 μA
Operating Voltage	10...30V DC
Voltage Drop	≤1.8V all models
Repeatability	≤5%
Hysteresis	≤10% typical
Protection Type	Transient noise, reverse polarity, short circuit, overload, and false pulse
Certifications	cULus Listed and CE Marked for all applicable directives
Enclosure Type Rating	NEMA 1, 2, 3, 4, 4X, 6P, 12, 13; IP67 (IEC 529)
Housing Material	Plastic barrel (Valox)
Connections	Cable (PVC/PUR): 2 m (6.5 ft), 5 m (16.4 ft), 10 m (32.8 ft) length, 4.4 mm (0.175 in.) diameter 3-conductor #26 AWG PVC or PUR Cable (Pigtail): 0.2 m (0.7 ft), 0.5 m (1.6 ft), 1 m (3.3 ft) length, Integral 4-pin micro QD Quick-Disconnect: 4-pin micro style
LED	Amber: output energized, 360° visibility
Operating Temperature [C (F)], Min	-25...+70 ° (-13...+158 °)
Shock	30 g, 11 ms
Vibration	55 Hz, 1 mm amplitude, 3 planes

Correction Factors

Target Material	Correction Factors
Steel	1.0
Stainless Steel	0.7...0.8
Brass	0.4...0.5
Aluminum	0.3...0.4
Copper	0.3...0.4

Tubular Sensors
872CP WorldProx™ 3-Wire DC
 Plastic Face/Threaded Plastic Barrel

Approximate Dimensions [mm (in.)]

Wiring Diagrams

Cable Style

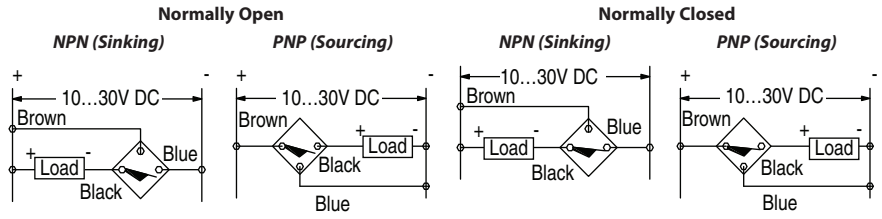
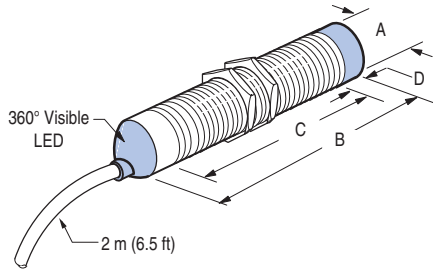

Thread Size	Shielded	[mm (in.)]			
		A	B (max)	C (min)	D (max)
M12 x 1	Yes	12.0 (0.47)	51.6 (2.03)	44.7 (1.76)	2.0 (0.08)
	No				
M18 x 1	Yes	18.0 (0.71)		46.2 (1.82)	
	No				
M30 x 1.5	Yes	30.0 (1.18)			
	No				

Micro QD Style

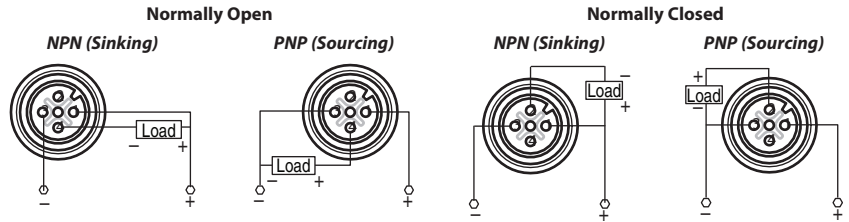
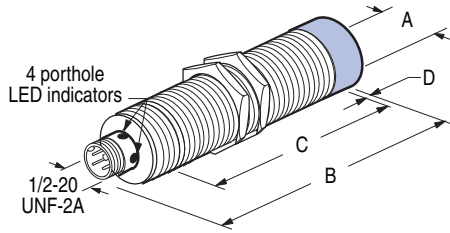

Thread Size	Shielded	[mm (in.)]			
		A	B (max)	C (min)	D (max)
M12 x 1	Yes	12.0 (0.47)	64.3 (2.53)	41.4 (1.63)	2.0 (0.08)
	No				
M18 x 1	Yes	18.0 (0.71)		46.2 (1.82)	
	No				
M30 X 1.5	Yes	30.0 (1.18)			
	No				

Tubular Sensors

872C WorldProx™ Long Range Sensing 3-Wire DC

Plastic Face/Threaded Chrome-Plated Brass Barrel



872C DC Micro Style
6.5, 8, 12, 18, and 30 mm



872C DC Pico Style
6.5 & 8 mm

Specifications

Load Current, DC, Max.	≤200 mA
Leakage Current	≤0.1 mA
Operating Voltage Range	10...30V DC
Sensor Voltage Drop	≤2V
Repeatability	≤5%
Hysteresis	10% typical
Protection Type	Reverse polarity, transient noise, short circuit, overload, and false pulse
Certifications	cULus Listed and CE Marked for all applicable directives
Enclosure Type Rating	NEMA 1, 2, 3, 4, 6P, 12, 13, IP67 (IEC 529) Chrome-plated brass barrel, plastic face (PBT)
Connections	Quick-disconnect: 4-pin micro style 3-pin pico style
LED	Amber: output energized, 360° visibility
Operating Temperature [C (F)]	-25...+70 ° (-13...+158 °)
Shock	30 g, 11 ms
Vibration	55 Hz, 1 mm amplitude, 3 planes

Correction Factors

Target Material	Correction Factors
Steel	1.0
Stainless Steel	0.6...0.8
Brass	0.3...0.6
Aluminum	0.3...0.5
Copper	0.2...0.5

Tubular Sensors

872C WorldProx™ Long Range Sensing 3-Wire DC

Plastic Face/Threaded Chrome-Plated Brass Barrel

Approximate Dimensions [mm (in.)]

Wiring Diagrams

Pico QD Style

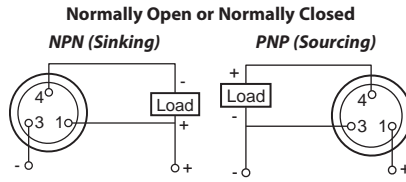
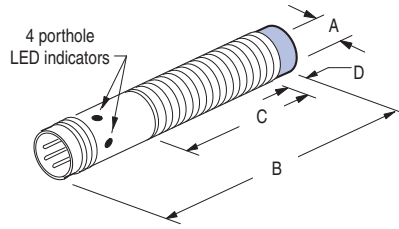

Thread Size	Smooth Diameter [mm]	Shielded	[mm (in.)]			
			A	B (max)	C (min)	D (max)
—	6.5	Yes	6.5 (0.26)	60 (2.36)	—	—
M8 x 1	—	No	8.0 (0.31)	60 (2.36)	41.5 (1.63)	4 (0.15)

Micro QD Style

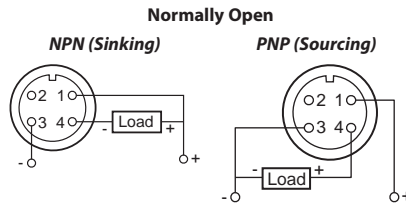
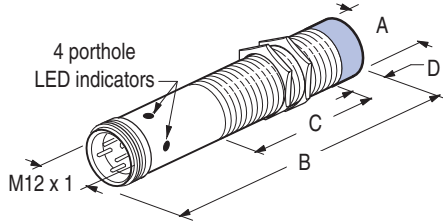

Thread Size	Smooth Diameter [mm]	Shielded	[mm (in.)]			
			A	B (max)	C (min)	D (max)
—	6.5	Yes	6.5 (0.26)	66 (2.59)	—	—
M8 x 1	—	No	8 (0.31)	66 (2.59)	40 (1.57)	4 (0.15)
M12 x 1	—	Yes	12 (0.47)	60 (2.36)	40 (1.57)	—
		No			35.3 (1.38)	5.7 (0.22)
M18 x 1	—	Yes	18 (0.71)	63.5 (2.5)	42 (1.65)	—
		No			32 (1.25)	10 (0.39)
M30 X 1.5	—	Yes	30 (1.18)	73.5 (2.89)	52 (2.04)	—
		No			42 (1.65)	10 (0.39)



872CP DC Cable Style
 12, 18, and 30 mm



872CP DC Micro Quick-Disconnect Style
 12, 18, and 30 mm



Pigtail Cable with Integral Micro QD Connector
 12, 18, and 30 mm

Specifications

Load Current	≤200 mA
Leakage Current	≤10 μA
Operating Voltage	10...30V DC
Voltage Drop	≤1.8V all models
Repeatability	≤5%
Hysteresis	≤10% typical
Protection Type	Transient noise, reverse polarity, short circuit, overload, and false pulse
Certifications	cULus Listed and CE Marked for all applicable directives
Enclosure Type Rating	NEMA 1, 2, 3, 4, 4X, 6P, 12, 13; IP67 (IEC 529)
Housing Material	Plastic barrel (Valox)
Connections	Cable (PVC/PUR): 2 m (6.5 ft), 5 m (16.4 ft), 10 m (32.8 ft) length, 4.4 mm (0.175 in.) diameter 3-conductor #26 AWG PVC or PUR Cable (Pigtail): 0.2 m (0.7 ft), 0.5 m (1.6 ft), 1 m (3.3 ft) length, Integral 4-pin micro QD Quick-Disconnect: 4-pin micro style
LED	Amber: output energized, 360° visibility
Operating Temperature [C (F)], Min	-25...+70 ° (-13...+158 °)
Shock	30 g, 11 ms
Vibration	55 Hz, 1 mm amplitude, 3 planes

Correction Factors

Target Material	Correction Factors
Steel	1.0
Stainless Steel	0.7...0.8
Brass	0.4...0.5
Aluminum	0.3...0.4
Copper	0.3...0.4

Tubular Sensors

872CP WorldProx™ 3-Wire DC

Plastic Face/Threaded Plastic Barrel

Approximate Dimensions [mm (in.)]

Wiring Diagrams

Cable Style

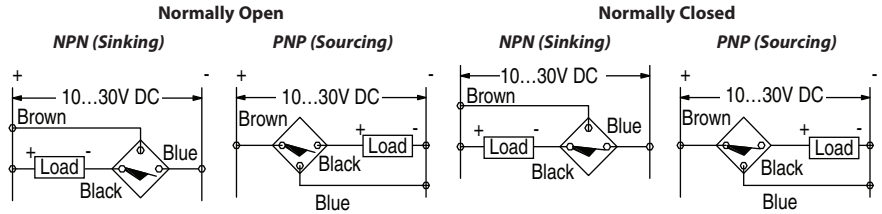
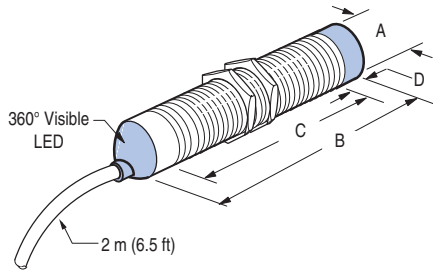

Thread Size	Shielded	[mm (in.)]			
		A	B (max)	C (min)	D (max)
M12 x 1	Yes	12.0 (0.47)	51.6 (2.03)	44.7 (1.76)	2.0 (0.08)
	No				
M18 x 1	Yes				
	No				
M30 x 1.5	Yes	30.0 (1.18)		46.2 (1.82)	
	No				

Micro QD Style

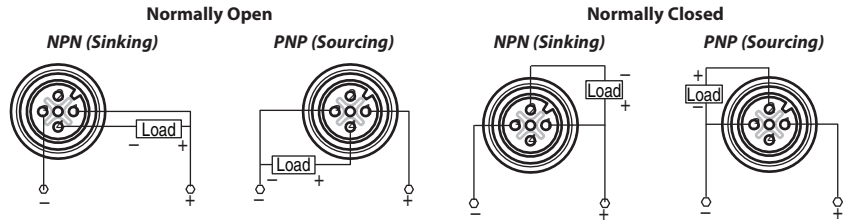
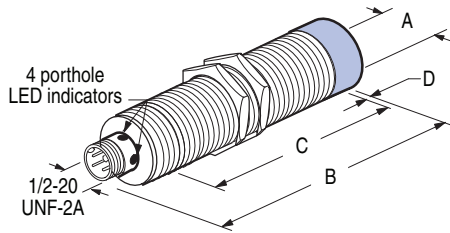

Thread Size	Shielded	[mm (in.)]			
		A	B (max)	C (min)	D (max)
M12 x 1	Yes	12.0 (0.47)	64.3 (2.53)	41.4 (1.63)	2.0 (0.08)
	No				
M18 x 1	Yes				
	No				
M30 X 1.5	Yes	30.0 (1.18)		46.2 (1.82)	
	No				

Tubular Sensors

872C WorldProx™ 4-Wire DC Complementary Output Plastic Face/Threaded Nickel-Plated Brass Barrel



872C DC Cable Style
12, 18, and 30 mm



872C DC Micro
Quick-Disconnect Style
12, 18, and 30 mm

Specifications

Load Current	≤200 mA
Leakage Current	≤10 μA
Operating Voltage	10...30V DC
Voltage Drop	≤1.6V
Repeatability	≤8%
Hysteresis	≤10% typical
Protection Type	False pulse, transient noise, reverse polarity, short circuit, and overload
Certifications	cULus Listed and CE Marked for all applicable directives
Enclosure Type Rating	NEMA 1, 2, 3, 4, 6P, 12, 13, IP67 (IEC 529)
Housing Material	Nickel-plated brass barrel
Connections	Cable: 2 m (6.5 ft) length 4-conductor PVC Quick-Disconnect: 4-pin micro style
LED	Red: Output Energized, 360° visibility
Operating Temperature [C (F)]	-25...+70 ° (-13...+158 °)
Shock	30 g, 11 ms
Vibration	55 Hz, 1 mm amplitude, 3 planes

Correction Factors

Target Material	Correction Factors
Steel	1.0
Stainless Steel	0.7...0.8
Brass	0.4...0.5
Aluminum	0.3...0.4
Copper	0.2...0.3

Tubular Sensors
872C WorldProx™ 4-Wire DC Complementary Output
 Plastic Face/Threaded Nickel-Plated Brass Barrel

Approximate Dimensions [mm (in.)]

Wiring Diagrams

Cable Style

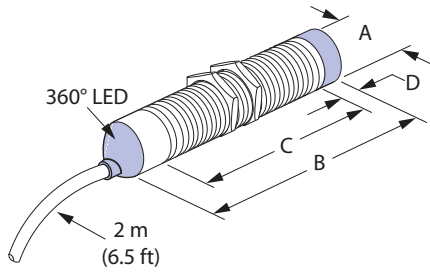

Complementary Normally Open and Normally Closed
 PNP (Sourcing)

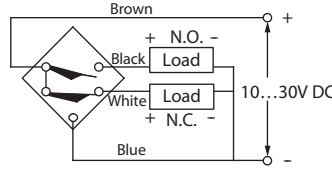

Thread Size	Shielded	[mm (in.)]		
		A	B	C
M12 x 1	Yes	12.0 (0.47)	50.8 (2.00)	46.7 (1.84)
M18 x 1		18.0 (0.71)		
M30 x 1.5		30.0 (1.18)		

Micro QD Style

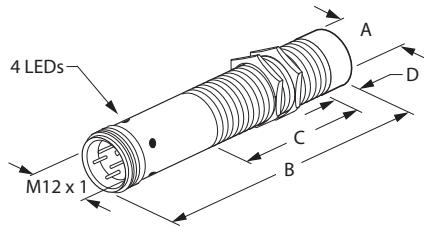

Complementary Normally Open and Normally Closed
 PNP (Sourcing)

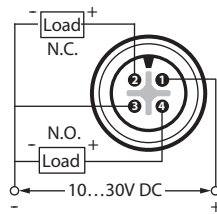

Thread Size	Shielded	[mm (in.)]		
		A	B	C
M12 x 1	Yes	12.0 (0.47)	65.0 (2.56)	38.1 (1.50)
M18 x 1		18.0 (0.71)		48.7 (1.88)
M30 X 1.5		30.0 (1.18)		



872C DC Cable Style
 12, 18, and 30 mm



**872C DC Micro
 Quick-Disconnect Style**
 12, 18, and 30 mm

Specifications

Load Current	≤100 mA
Load Current, Min.	5 mA
Leakage Current	≤0.9 mA
Operating Voltage	10...30V DC
Voltage Drop	≤6V
Repeatability	≤2%
Hysteresis	10% typical
Protection Type	False pulse, transient noise, reverse polarity, short circuit, and overload
Certifications	cULus Listed and CE Marked for all applicable directives
Enclosure Type Rating	NEMA 1, 2, 3, 4, 6P, 12, 13; IP67 (IEC529)
Housing Material	Nickel-plated brass barrel, plastic face (PBT)
Connections	Cable: 2 m (6.5 ft) length 2-conductor #26 AWG PVC Quick-Disconnect: 4-pin micro style
LED	Red: Output energized, 360° visibility
Operating Temperature [C (F)]	-25...+70 ° (-13...+158 °)
Shock	30 g, 11 ms
Vibration	55 Hz, 1 mm amplitude, 3 planes

Correction Factors

Target Material	Correction Factors
Steel	1.0
Stainless Steel	0.7...0.8
Brass	0.4...0.5
Aluminum	0.3...0.4
Copper	0.2...0.3

Tubular Sensors
872C WorldProx™ 2-Wire DC
 Plastic Face/Threaded Nickel-Plated Brass Barrel

Approximate Dimensions [mm (in.)]

Wiring Diagrams

Cable Style

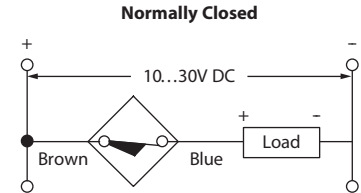
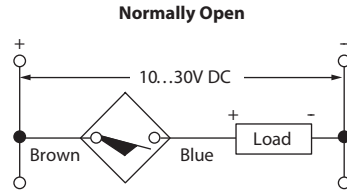
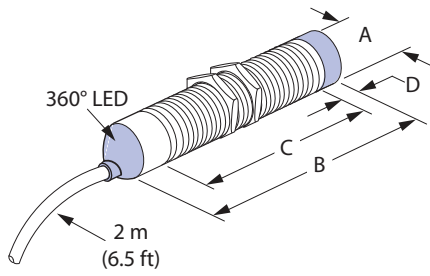

Note: Load can be switched to brown wire.

Thread Size	Shielded	[mm (in.)]			
		A	B (max)	C (min)	D (max)
M12 x 1	Yes	12.0 (0.47)	50.8 (2.00)	46.7 (1.84)	—
	No		58.7 (2.31)		7.9 (0.31)
M18 x 1	Yes	18.0 (0.71)	50.8 (2.00)		—
	No		63.0 (2.48)		12.2 (0.48)
M30 x 1.5	Yes	30.0 (1.18)	50.8 (2.00)	—	
	No		63.0 (2.48)	12.2 (0.48)	

Micro QD Style

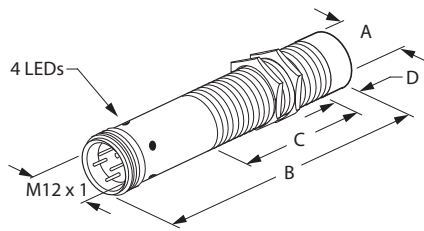

Normally Open or Normally Closed

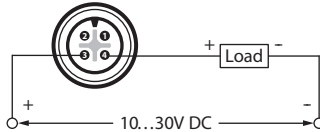

Note: Load can be switched to pin 3.

Thread Size	Shielded	[mm (in.)]			
		A	B (max)	C (min)	D (max)
M12 x 1	Yes	12.0 (0.47)	65.0 (2.56)	38.1 (1.50)	—
	No		72.4 (2.85)		7.9 (0.31)
M18 x 1	Yes	18.0 (0.71)	65.0 (2.56)		—
	No		76.5 (3.01)		12.2 (0.48)
M30 x 1.5	Yes	30.0 (1.18)	65.0 (2.56)	46.7 (1.84)	—
	No		76.5 (3.01)		12.2 (0.48)

Tubular Sensors
872C WorldProx™ QuadroPlex™ 2-Wire DC
 Plastic Face/Threaded Nickel-Plated Brass Barrel



872C DC Micro
Quick-Disconnect Style
12, 18, and 30 mm

Specifications

	12 mm	18 and 30 mm
Load Current	100 mA	200 mA
Load Current, Min.	5 mA	
Leakage Current	≤1 mA	
Operating Voltage	10...30V DC	
Voltage Drop	≤6.0V @ 100 mA	≤6.5V @ 200 mA, ≤6.0V @ 100 mA
Repeatability	≤10% at constant temperature	
Hysteresis	10% typical	
Protection Type	False pulse, transient noise, short circuit, and overload	
Certifications	cULus Listed and CE Marked for all applicable directives	
Enclosure Type Rating	NEMA 1, 2, 3, 4, 6P, 12, 13; IP67 (IEC529)	
Housing Material	Nickel-plated brass barrel, plastic face (PBT)	
Connections	Quick-Disconnect: 4-pin micro style	
LED	Red: Output energized, 360° visibility	
Operating Temperature [C (F)]	-25...+70 ° (-13...+158 °)	
Shock	30 g, 11 ms	
Vibration	55 Hz, 1 mm amplitude, 3 planes	

Correction Factors

Target Material	Correction Factors
Steel	1.0
Stainless Steel	0.7...0.8
Brass	0.4...0.5
Aluminum	0.3...0.4
Copper	0.2...0.3

Tubular Sensors
872C WorldProx™ QuadroPlex™ 2-Wire DC
 Plastic Face/Threaded Nickel-Plated Brass Barrel

Approximate Dimensions [mm (in.)]

Micro QD Style

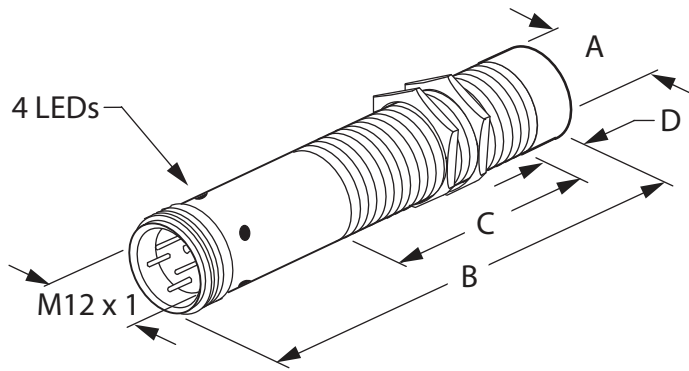

Thread Size	Shielded	[mm (in.)]			
		A	B (max)	C (min)	D (max)
M12 x 1	Yes	12.0 (0.47)	65.0 (2.56)	38.1 (1.50)	—
	No		72.4 (2.85)		7.9 (0.31)
M18 x 1	Yes	18.0 (0.71)	65.0 (2.56)		—
	No		76.5 (3.01)		
M30 x 1.5	Yes	30.0 (1.18)	65.0 (2.56)	—	
	No		76.5 (3.01)		12.2 (0.48)

Wiring Diagrams

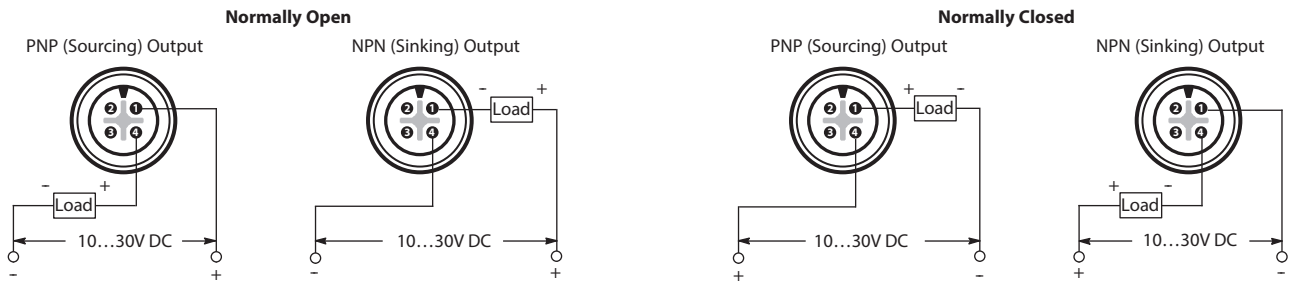

Tubular Sensors
872C WorldProx™ 2-Wire AC
 Plastic Face/Threaded Nickel-Plated Brass Barrel

Specifications

	8 mm	12, 18, and 30 mm
Load Current, Max.	100 mA	≤300 mA
Load Current, Min.	5 mA	
Inrush Current	≤2 A	
Leakage Current	≤2 mA	
Operating Voltage	20...240V AC	20...250V AC
Voltage Drop	≤5V	
Repeatability	≤5%	
Hysteresis	≤15% typical	
Protection Type	False pulse and transient noise	
Certifications	cULus Listed (12, 18, and 30 mm models only) and CE Marked (all models) for all applicable directives	
Enclosure Type Rating	NEMA 1, 2, 3, 4, 12, 13; IP67 (IEC 529)	
Housing Material	Nickel-plated brass barrel	
Connection Type	Cable: 2 m (6.5 ft) length, 3-conductor PVC Quick-Disconnect: 3-pin micro style, 3-pin mini style	
LED	Red: output energized, 360° visibility	
Operating Temperature [C (F)]	-25...+70 ° (-13...+158 °)	
Shock	30 g, 11 ms	
Vibration	55 Hz, 1 mm amplitude, 3 planes	



872C AC Cable Style
8 mm



872C AC Cable Style
12, 18, and 30 mm



872C AC Mini
Quick-Disconnect Style
18 & 30 mm



872C AC Micro
Quick-Disconnect Style
12, 18, and 30 mm

Correction Factors

Target Material	Correction Factors
Steel	1.0
Stainless Steel	0.9
Brass	0.5
Aluminum	0.45
Copper	0.4

Approximate Dimensions [mm (in.)]

Cable Style

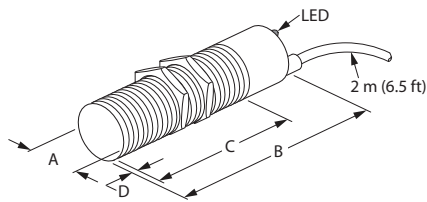

Wiring Diagrams

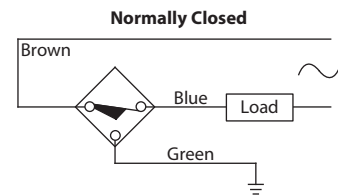
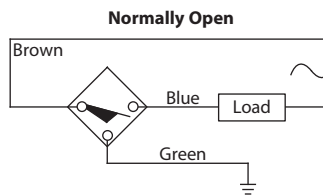

Note: Load can be switched to brown wire.

Thread Size	Shielded	[mm (in.)]			
		A	B	C	D
M8 x 1	Yes	8.0 (0.31)	47.0 (1.85)	36.0 (1.42)	—
	No	6.0 (0.24)			6.0 (0.24)
M12 x 1	Yes	12.0 (0.47)	70.0 (2.76)	60.0 (2.36)	—
	No			54.0 (2.13)	6.0 (0.24)
M18 x 1	Yes	18.0 (0.71)	60.0 (2.36)	50.0 (1.96)	—
	No			42.0 (1.65)	8.0 (0.31)
M30 x 1	Yes	30.0 (1.18)	60.0 (2.36)	50.0 (1.96)	—
	No			38.0 (1.50)	12.0 (0.47)

Tubular Sensors
872C WorldProx™ 2-Wire AC
 Plastic Face/Threaded Nickel-Plated Brass Barrel

Approximate Dimensions [mm (in.)]

Wiring Diagrams

Mini QD Style

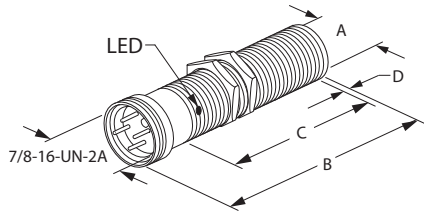

Normally Open or Normally Closed

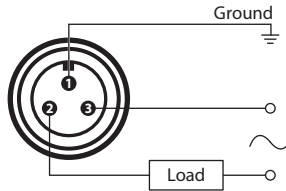

Note: Load can be switched to pin 3.

Thread Size	Shielded	[mm (in.)]			
		A	B	C	D
M18 x 1	Yes	18.0 (0.71)	91.0 (3.58)	52.0 (2.05)	—
	No			44.0 (1.73)	8.0 (0.31)
M30 X 1.5	Yes	30.0 (1.18)	91.0 (3.58)	52.0 (2.05)	—
	No			40.0 (1.57)	12.0 (0.47)

Micro QD Style

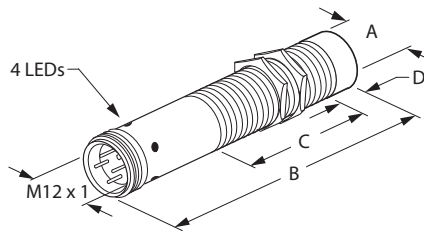

Normally Open or Normally Closed

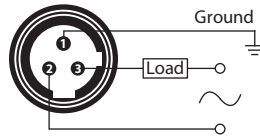

Note: Load can be switched to pin 2.

Thread Size	Shielded	[mm (in.)]			
		A	B	C	D
M12 x 1	Yes	12.0 (0.47)	75.0 (2.95)	45.0 (1.77)	—
	No			40.0 (1.57)	6.0 (0.24)
M18 x 1	Yes	18.0 (0.71)	80.0 (3.15)	60.0 (2.36)	—
	No			52.0 (2.05)	8.0 (0.31)
M30 X 1.5	Yes	30.0 (1.18)	80.0 (3.15)	50.0 (1.96)	—
	No			38.0 (1.50)	12.0 (0.47)

Tubular Sensors
872C WorldProx™ 2-Wire AC Extended Sensing
 Plastic Face/Threaded Nickel-Plated Brass Barrel



872C AC Cable Style
12, 18, and 30 mm



872C AC Mini
Quick-Disconnect Style
18 & 30 mm



872C AC Micro
Quick-Disconnect Style
12, 18, and 30 mm

Specifications

Load Current, Max.	300 mA
Load Current, Min.	2 mA
Inrush Current (1 cycle)	≤2 A
Leakage Current	≤1.7 mA
Operating Voltage	20...250V AC
Voltage Drop	≤11V @ 10 mA, ≤7V @ 300 mA
Repeatability	≤5%
Hysteresis	≤10% typical
Protection Type	False pulse, transient noise, overload, and short circuit
Certifications	cULus Listed and CE Marked for all applicable directives
Enclosure Type Rating	NEMA 1, 2, 3, 4, 12, 13; IP67 (IEC 529)
Connection Type	Cable: 2 m (6.5 ft) length, 3-conductor PVC Quick-Disconnect: 3-pin micro style, 3-pin mini style
LED	Cable Models: yellow - power, green - output energized QD Models: green - power, red - output energized
Operating Temperature [C (F)]	-25...+70 ° (-13...+158 °)
Shock	30 g, 11 ms
Vibration	55 Hz, 1 mm amplitude, 3 planes

Correction Factors

Target Material	Correction Factors
Steel	1.0
Stainless Steel	0.9
Brass	0.5
Aluminum	0.45
Copper	0.4

Tubular Sensors

872C WorldProx™ 2-Wire AC Extended Sensing

Plastic Face/Threaded Nickel-Plated Brass Barrel

Approximate Dimensions [mm (in.)]

Wiring Diagrams

Cable Style

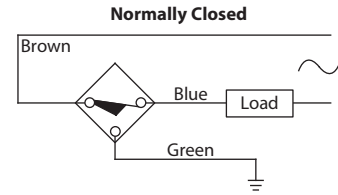
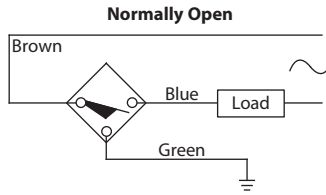
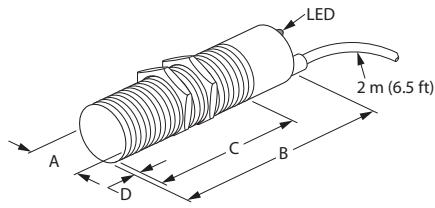

Note: Load can be switched to brown wire.

Thread Size	Shielded	[mm (in.)]			
		A	B	C	D
M12 x 1	Yes	12.0 (0.47)	70.0 (2.76)	60.0 (2.36)	—
	No			54.0 (2.13)	6.0 (0.24)
M18 x 1	Yes	18.0 (0.71)	60.0 (2.36)	50.0 (1.96)	—
	No			42.0 (1.65)	8.0 (0.31)
M30 x 1	Yes	30.0 (1.18)	60.0 (2.36)	50.0 (1.96)	—
	No			38.0 (1.50)	12.0 (0.47)

Mini QD Style

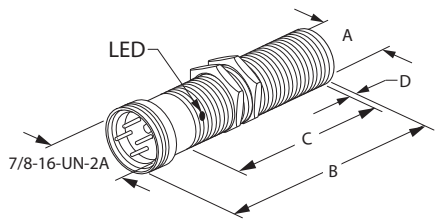

Normally Open or Normally Closed

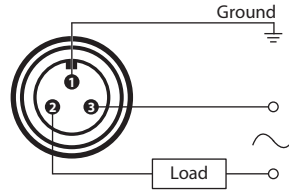

Note: Load can be switched to pin 3.

Thread Size	Shielded	[mm (in.)]			
		A	B	C	D
M18 x 1	Yes	18.0 (0.71)	91.0 (3.58)	52.0 (2.05)	—
	No			44.0 (1.73)	8.0 (0.31)
M30 X 1.5	Yes	30.0 (1.18)	91.0 (3.58)	52.0 (2.05)	—
	No			40.0 (1.57)	12.0 (0.47)

Micro QD Style

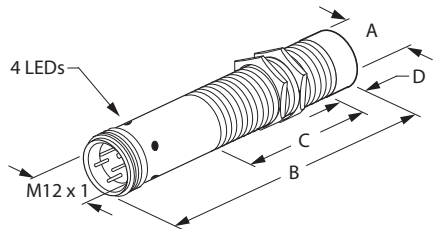

Normally Open or Normally Closed

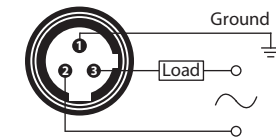

Note: Load can be switched to pin 2.

Thread Size	Shielded	[mm (in.)]			
		A	B	C	D
M12 x 1	Yes	12.0 (0.47)	75.0 (2.95)	45.0 (1.77)	—
	No			40.0 (1.57)	6.0 (0.24)
M18 x 1	Yes	18.0 (0.71)	80.0 (3.15)	60.0 (2.36)	—
	No			52.0 (2.05)	8.0 (0.31)
M30 X 1.5	Yes	30.0 (1.18)	80.0 (3.15)	50.0 (1.96)	—
	No			38.0 (1.50)	12.0 (0.47)



872C AC Cable Style
12, 18, and 30 mm



872C AC Micro
Quick-Disconnect Style
12, 18, and 30 mm

Specifications

	12 mm	18 & 30 mm
Load Current, Max.	300 mA	350 mA
Load Current, Min.	2 mA	
Inrush Current (1 cycle)	≤2 A	
Leakage Current	≤1.7 mA @ 120V and ≤1.9 mA @ 250V	
Operating Voltage	20...250V AC/DC	
Voltage Drop	≤5V	
Repeatability	≤5%	
Hysteresis	≤10% typical	
Protection Type	False pulse, transient noise, overload, and short circuit	
Certifications	cULus Listed and CE Marked for all applicable directives	
Enclosure Type Rating	NEMA 1, 2, 3, 4, 12, 13; IP67 (IEC 529)	
Housing Material	Nickel-plated brass barrel	
Connection Type	Cable: 2 m (6.5 ft) length, 3-conductor PVC Quick-Disconnect: 3-pin micro style, 3-pin mini style	
LED	Red: output energized, 360° visibility	
Operating Temperature [C (F)]	-25...+70 ° (-13...+158 °)	
Shock	30 g, 11 ms	
Vibration	55 Hz, 1 mm amplitude, 3 planes	

Correction Factors

Target Material	Correction Factors
Steel	1.0
Stainless Steel	0.9
Brass	0.5
Aluminum	0.4
Copper	0.4

Tubular Sensors
872C WorldProx™ 2-Wire AC/DC
 Plastic Face/Threaded Nickel-Plated Brass Barrel

Approximate Dimensions [mm (in.)]

Wiring Diagrams

Cable Style

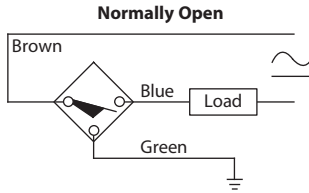
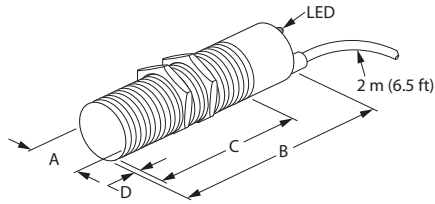

Note: Load can be switched to brown wire.

Thread Size	Shielded	[mm (in.)]			
		A	B	C	D
M12 x 1	Yes	12.0 (0.47)	70.0 (2.76)	60.0 (2.36)	—
	No			54.0 (2.13)	6.0 (0.24)
M18 x 1	Yes	18.0 (0.71)	60.0 (2.36)	50.0 (1.96)	—
	No			42.0 (1.65)	8.0 (0.31)
M30 x 1.5	Yes	30.0 (1.18)	60.0 (2.36)	50.0 (1.96)	—
	No			38.0 (1.50)	12.0 (0.47)

Micro QD Style

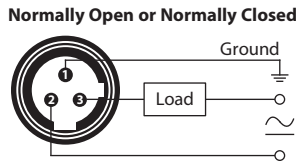
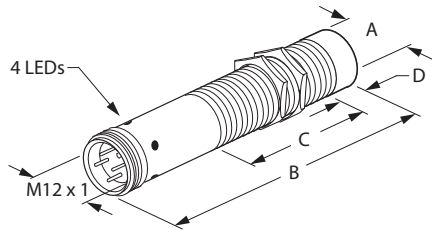

Note: Load can be switched to pin 2.

Thread Size	Shielded	[mm (in.)]			
		A	B	C	D
M12 x 1	Yes	12.0 (0.47)	75 (2.95)	45.0 (1.77)	—
	No			40.0 (1.57)	6.0 (0.24)
M18 x 1	Yes	18.0 (0.71)	80.0 (3.15)	60.0 (2.36)	—
	No			52.0 (2.05)	8.0 (0.31)
M30 X 1.5	Yes	30.0 (1.18)	80.0 (3.15)	50.0 (1.96)	—
	No			38.0 (1.50)	12.0 (0.47)

Tubular Sensors

872C WorldProx™ 2-Wire AC/DC Relay Output Threaded Nickel-Plated Brass Barrel



872C AC/DC Cable Style
30 mm

Specifications

Load Current	Switched Power, Max. — 84 W or 900V A Switched Current, Max. — 3 A SPDT Switched Voltage, Max. — 28V DC or 300V AC Relay Life — 20,000,000 operations (no load), 100,000 operations (full load)
Operating Voltage	30...132V AC/DC
Repeatability	≤10% at constant temperature
Hysteresis	≤10% typical
Protection Type	False pulse, transient noise, and reverse polarity
Certifications	cULus Listed and CE Marked for all applicable directives CCC Certified (select models)
Enclosure Type Rating	NEMA 1, 2, 3, 3R 4, 6, 6P, 12, 13; IP67 (IEC 529)
Housing Material	Nickel-plated brass barrel
Connection Type	Cable: 2 m (6.5 ft) length, 5-conductor 22 AWG PVC cable
LED	Red: Output Energized, 360° visibility
Operating Temperature [C (F)]	-25...+70 ° (-13...+158 °)
Shock	30 g, 11 ms
Vibration	55 Hz, 1 mm amplitude, 3 planes

Correction Factors

Target Material	Correction Factors
Steel	1.0
Stainless Steel	0.7...0.8
Brass	0.4...0.5
Aluminum	0.3...0.4
Copper	0.2...0.3

Approximate Dimensions [mm (in.)]

Cable Style

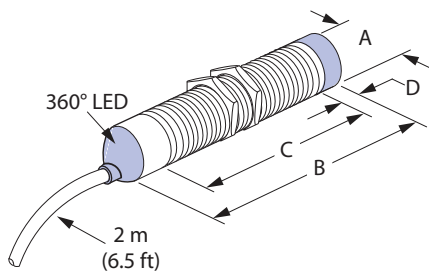

Wiring Diagrams

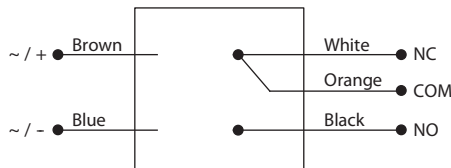

Thread Size	Shielded	[mm (in.)]			
		A	B (max)	C (min)	D (max)
M30 x 1.5	Yes	30.0 (1.18)	61.0 (2.40)	57.0 (2.24)	—
	No		73.0 (2.87)		12.2 (0.48)

Rectangular Sensors

802PR 2-Wire AC, High Output

Limit Switch Style



802PR AC
Cable Style



802PR AC Mini
Quick-Disconnect Style



802PR AC
Conduit Style

Specifications

Load Current	≤1 A at 40 °C linearly derated to 0.5 A at 75 °C
Inrush Current	≤10 A/1 s
Current Consumption	25 mA, min.
Leakage Current	≤3.5 mA (60...132V AC); ≤6.5 mA (102...132V AC)
Operating Voltage	60...132V AC or 102...132V AC
Voltage Drop	≤8.5V
Repeatability	≤0.025 mm
Hysteresis	15% (max.)
Protection Type	False pulse, transient noise
Certifications	UL Listed, CSA Certified, and CE Marked for all applicable directives
Enclosure Type Rating	NEMA 1, 2, 3, 4, 4X, 12, 13, IP65 (IEC529) ★
Housing Material	Self-extinguishing glass reinforced polyester body
Connection Type	Cable: 2.4 m (8 ft) or 3.7 m (12 ft) length, 2-conductor 16 AWG STO (oil-resistant thermoplastic); Quick-Disconnect: 3-pin mini; Conduit Opening or Conduit Coupler: 1/2-14 NPT internal thread with screw terminals (use #18...14 AWG wire)
LED	Red: Output Energized
Operating Temperature [C (F)]	-25...+75 ° (-13...+167 °)
Shock	30 g, 11 ms
Vibration	55 Hz, 1 mm amplitude, 3 planes

★ NEMA 4X enclosure rating applies only to corrosion-resistant models.

Correction Factors

Target Material	Correction Factors
Steel	1.0
Stainless Steel	0.8...0.85
Brass	0.5...0.55
Aluminum	0.45...0.5
Copper	0.4...0.45

Approximate Dimensions [mm (in.)]

Cable Style

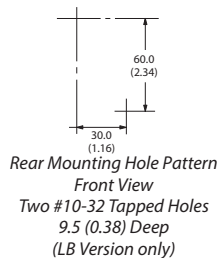
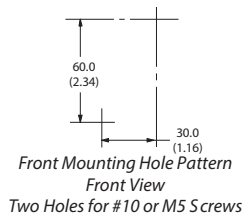
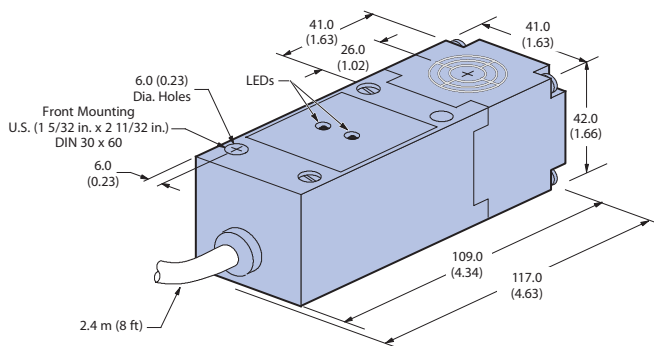

Wiring Diagrams

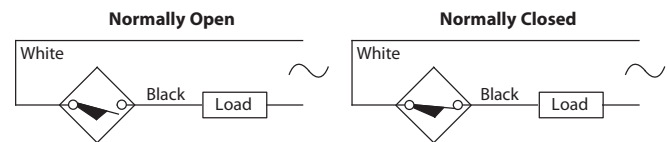

Note: Load can be switched to white lead.

Note 1: Side sensing model heads can be turned in 90° increments to accommodate four side sensing positions.
Note 2: Low voltage models have two LEDs.

Approximate Dimensions [mm (in.)]

Mini QD Style

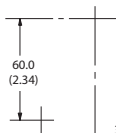
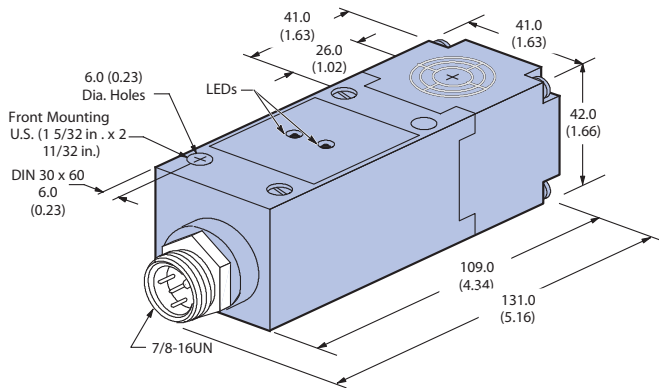

Front Mounting Hole Pattern
 Front View
 Two Holes for #10 or M5 Screws

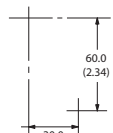

Rear Mounting Hole Pattern
 Front View
 Two #10-32 Tapped Holes
 9.5 (0.38) Deep
 (LB Version only)

Note 1: Side sensing model heads can be turned in 90° increments to accommodate four side sensing positions.
Note 2: Low voltage models have two LEDs.

Wiring Diagrams

Normally Open or Normally Closed

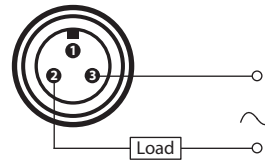

Note: Load can be switched to pin 3.

Conduit Style

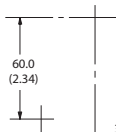
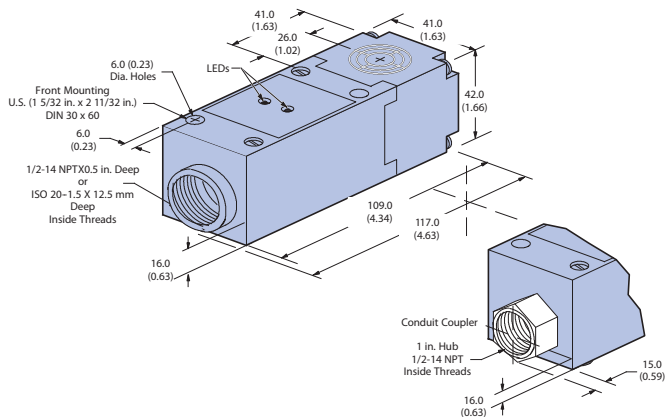

Front Mounting Hole Pattern
 Front View
 Two Holes for #10 or M5 Screws

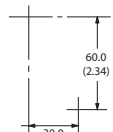

Rear Mounting Hole Pattern
 Front View
 Two #10-32 Tapped Holes
 9.5 (0.38) Deep
 (LB Version only)

Normally Open

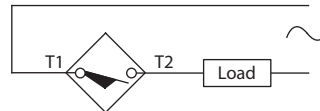

Normally Closed

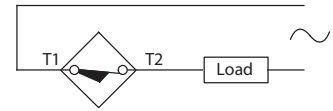

Note: Load can be switched to terminal 1.

Note 1: Side sensing model heads can be turned in 90° increments to accommodate four side sensing positions.
Note 2: Low voltage models have two LEDs.

Rectangular Sensors

802PR 2-Wire AC Hazardous Location, High Output Limit Switch Style



802PR AC/DC
Conduit Style

Specifications

Load Current	≤1 A at 40 °C linearly derated to 0.5 A at 75 °C
Inrush Current	≤10 A/1 s
Current Consumption	25 mA, min.
Leakage Current	≤6.5 mA
Operating Voltage	102...132V AC
Voltage Drop	≤8.5V
Repeatability	≤0.025 mm
Hysteresis	15% (max.)
Protection Type	False pulse, transient noise
Certifications	UL Listed and CSA Certified
Enclosure Type Rating	NEMA 1, 2, 3, 4, 12, 13; IP65 (IEC529) Division 2 Class I: Groups A, B, C & D; Class II: Groups F & G; Class III: All groups
Housing Material	Self-extinguishing glass reinforced polyester body
Connection Type	Conduit Coupler: 1/2 -14NPT internal thread with screw terminals (use #18...14 AWG wire)
LED	Red: Output Energized
Operating Temperature [C (F)]	-25...+75 ° (-13...+167 °)
Shock	30 g, 11 ms
Vibration	55 Hz, 1 mm amplitude, 3 planes

Correction Factors

Target Material	Correction Factors
Steel	1.0
Stainless Steel	0.8...0.85
Brass	0.5...0.55
Aluminum	0.45...0.5
Copper	0.4...0.45

Rectangular Sensors 802PR 2-Wire AC Hazardous Location, High Output Limit Switch Style

Approximate Dimensions [mm (in.)]

Conduit Style

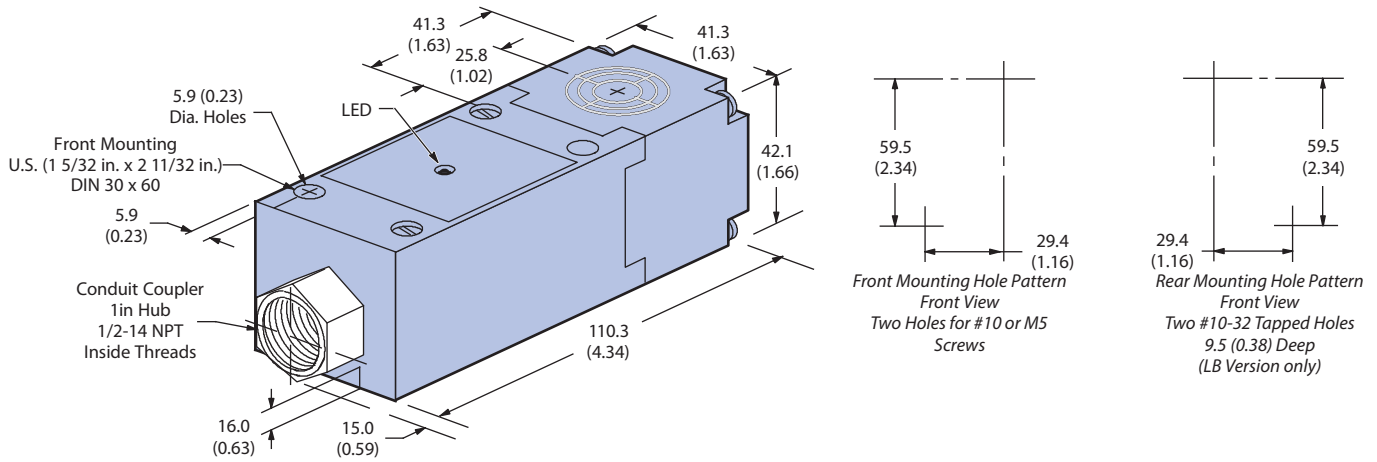

Note: Side sensing model heads can be turned in 90° increments to accommodate four side sensing positions.

Wiring Diagrams

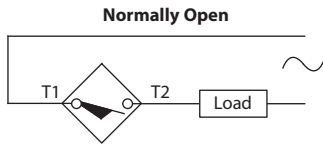

Note: Load can be switched to terminal 1.

Rectangular Sensors

802PR 2-Wire AC/DC

Limit Switch Style



802PR AC/DC
Cable Style



802PR AC/DC Mini
Quick-Disconnect Style



802PR AC/DC Micro
Quick-Disconnect Style



802PR AC/DC
Conduit Style

Specifications

Load Current	AC 4...25 mA; DC 2...25 mA
Leakage Current	≤1.7 mA at 132V, ≤2.5 mA at 250V
Operating Voltage	20...250V AC/DC
Voltage Drop	≤10V
Repeatability	≤10% typical
Hysteresis	≤10% typical
Protection Type	Transient noise, short circuit, overload, false pulse, radio frequency (10V per meter; frequency range 20...1000 MHz)
Certifications	UL Listed, CSA Certified, and CE Marked for all applicable directives
Enclosure Type Rating	NEMA 1, 2, 3, 4, 4X, 12, 13, IP65 (IEC529) ★
Housing Material	Self extinguishing glass-reinforced polyester body
Connection Type	Cable: 2.4 m (8 ft) length, 2-conductor ToughLink; Quick-Disconnect: 3-pin micro style, 3-pin mini style; Conduit Opening or Conduit Coupler: Internal thread with screw terminals (use #18...14 AWG wire)
LED	Green: Power; Red: Output energized (both on in SCP/Overload)
Operating Temperature [C (F)]	-25...+75 ° (-13...+167 °)
Shock	30 g, 11 ms
Vibration	55 Hz, 1 mm amplitude, 3 planes

★ NEMA 4X enclosure rating applies only to corrosion-resistant models.

Correction Factors

Target Material	Correction Factors
Steel	1.0
Stainless Steel	0.9
Brass	0.8
Aluminum	0.75
Copper	0.7

Approximate Dimensions [mm (in.)]

Cable Style

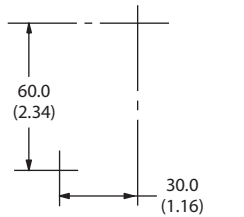
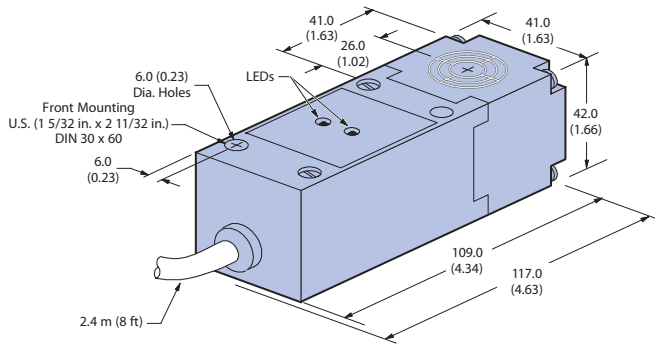

Front Mounting Hole Pattern Front View
 Two Holes for #10 or M5 Screws

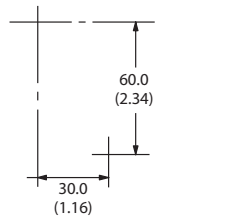

Rear Mounting Hole Pattern Front View
 Two #10-32 Tapped Holes 9.5 (0.38) Deep (LB Version only)

Mini QD Style

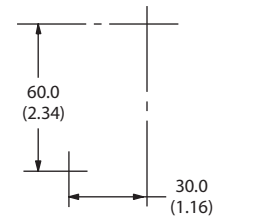
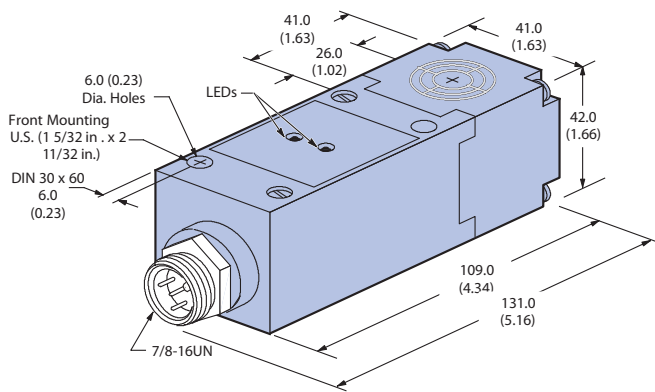

Front Mounting Hole Pattern Front View
 Two Holes for #10 or M5 Screws

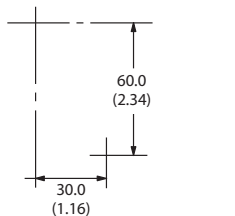

Rear Mounting Hole Pattern Front View
 Two #10-32 Tapped Holes 9.5 (0.38) Deep (LB Version only)

Wiring Diagrams

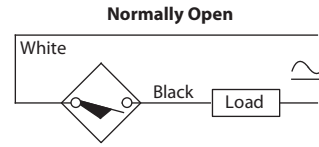

Note: Load can be switched to white lead.

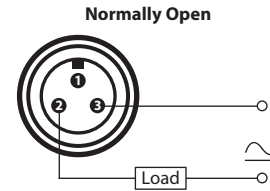

Note: Load can be switched to pin 3.

Rectangular Sensors

802PR 2-Wire AC/DC

Limit Switch Style

Approximate Dimensions [mm (in.)]

Micro QD Style

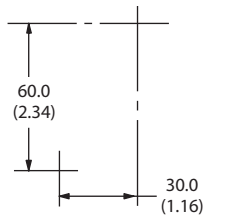
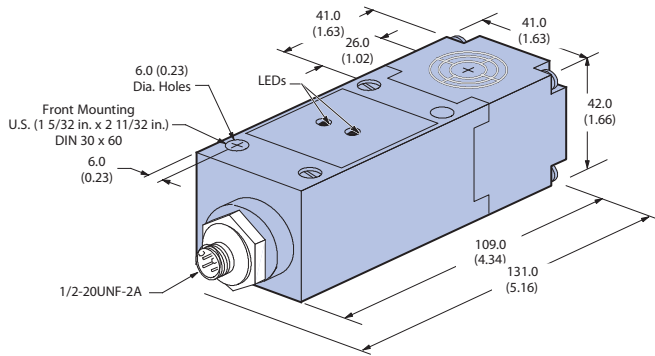

Front Mounting Hole Pattern Front View
Two Holes for #10 or M5 Screws

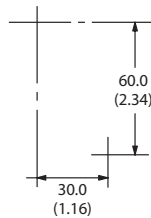

Rear Mounting Hole Pattern Front View
Two #10-32 Tapped Holes 9.5 (0.38) Deep (LB Version only)

Wiring Diagrams

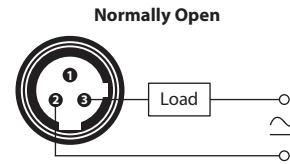

Note: Load can be switched to pin 2.

Conduit Style

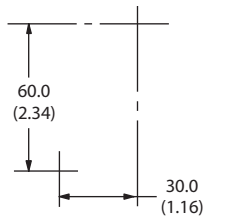
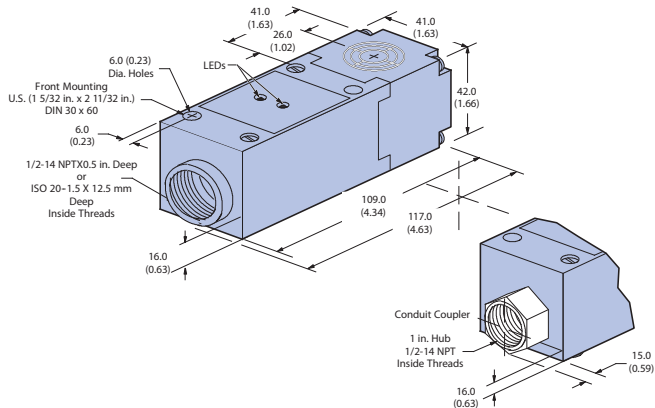

Front Mounting Hole Pattern Front View
Two Holes for #10 or M5 Screws

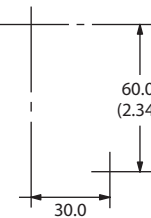

Rear Mounting Hole Pattern Front View
Two #10-32 Tapped Holes 9.5 (0.38) Deep (LB Version only)

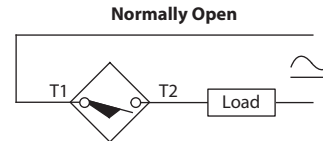

Note: Load can be switched to terminal 1.

Note: Side sensing model heads can be turned in 90° increments to accommodate four side sensing positions.



802PR AC
 Conduit Style

Specifications

Load Current	AC: 4...25 mA, DC: 2...25 mA
Leakage Current	≤1.7 mA at 132V, ≤2.5 mA at 250V
Operating Voltage	20...250V AC/DC
Voltage Drop	≤10V
Repeatability	≤10% typical
Hysteresis	≤10% typical
Protection Type	Transient noise, short circuit, overload, false pulse, radio frequency (≤10V per meter; frequency range 20...1000 MHz)
Certifications	UL Listed and CSA Certified
Enclosure Type Rating	NEMA 1, 2, 3, 4, 12, 13; IP65 (IEC529); Division 2 Class I: Groups A, B, C & D; Class II: Groups F & G; Class III: All groups
Housing Material	Self-extinguishing glass-reinforced polyester body
Connection Type	Conduit Coupler: 1/2 - 14 NPT internal thread with screw terminals, use #18...14 AWG wire
LED	Green: Power, Red: Output energized (both on in SCP/Overload)
Operating Temperature [C (F)]	-25...+75 ° (-13...+167 °)
Shock	30 g, 11 ms
Vibration	55 Hz, 1 mm amplitude, 3 planes

Correction Factors

Target Material	Correction Factors
Steel	1.0
Stainless Steel	0.9
Brass	0.8
Aluminum	0.75
Copper	0.7

Approximate Dimensions [mm (in.)]

Conduit Style

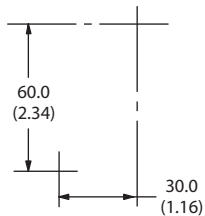
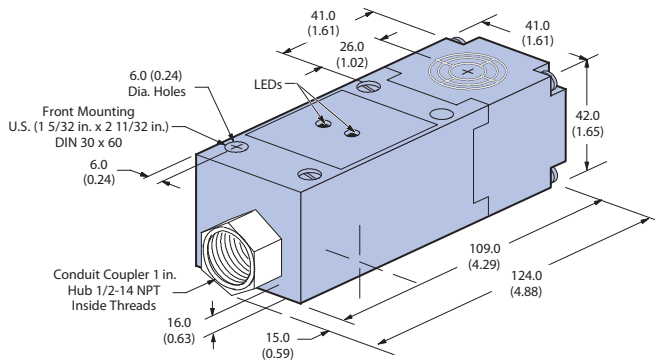

Front Mounting Hole Pattern Front View
 Two Holes for #10 or M5 Screws

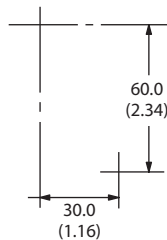

Rear Mounting Hole Pattern Front View
 Two #10-32 Tapped Holes 9.5 (0.38) Deep (LB Version only)

Wiring Diagrams

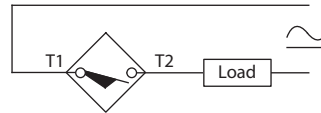

Note: Load can be switched to terminal 1.

Note: Side-sensing model heads can be turned in 90° increments to accommodate four side-sensing positions.

Rectangular Sensors
871F 3-Wire DC
 Block Style



871F DC Cable Style



871F DC Micro
 Quick-Disconnect Style

Specifications

Load Current	≤400 mA
Load Current, Min.	1 mA
Leakage Current	≤10 μA
Operating Voltage	10...30V DC
Voltage Drop	≤2.4V
Repeatability	≤10%
Hysteresis	≤15% typical
Protection Type	False pulse, transient noise, reverse polarity, short circuit, and overload
Certifications	CE Marked for all applicable directives
Enclosure Type Rating	NEMA 1, 2, 3, 4, 12, 13; IP67 (IEC529)
Housing Material	Aluminum Body
Connection Type	Cable: 2 m (6.5 ft) length, 3-conductor PVC; Quick-Disconnect: 4-pin micro style
Indicator LEDs	Orange: Output Energized
Operating Temperature [C (F)]	-25...+70 ° (-13...+158 °)
Shock	30 g, 11 ms
Vibration	55 Hz, 1 mm amplitude, 3 planes

Correction Factors

Target Material	Correction Factor
Steel	1.0
Stainless Steel	0.7...0.8
Brass	0.4...0.5
Aluminum	0.3...0.4
Copper	0.2...0.3

Approximate Dimensions [mm (in.)]

Cable Style

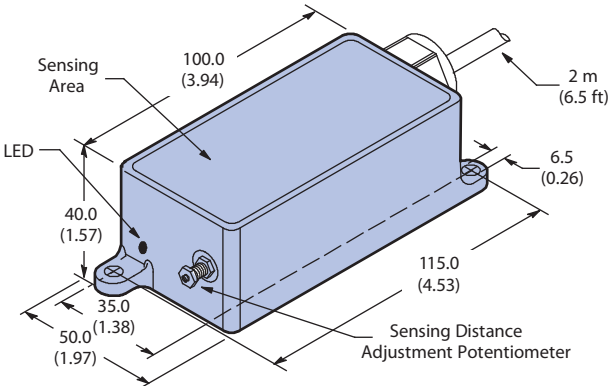

Micro QD Style

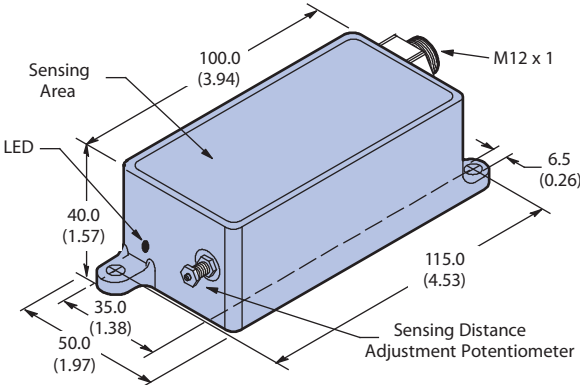

Wiring Diagrams

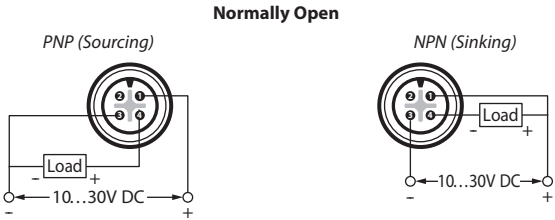
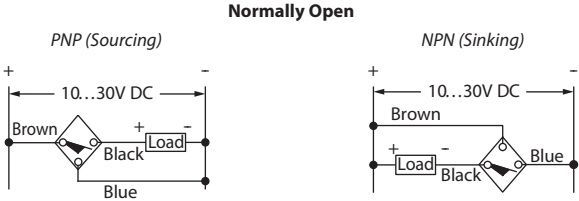

Rectangular Sensors
871F 4-Wire DC Complementary Output
 Flat Pack Style



871F DC Mini
 Quick-Disconnect Style



871F DC Micro
 Quick-Disconnect Style

Specifications

Load Current, Max.	200 mA
Load Current, Min.	1 mA
Leakage Current	≤10 μA
Operating Voltage	10...30V DC
Voltage Drop	≤2.5V
Repeatability	≤2%
Hysteresis	≤5% typical
Protection Type	False pulse, transient noise, reverse polarity, short circuit, overload
Certifications	cULus Listed and CE Marked for all applicable all directives
Enclosure Type Rating	NEMA 1, 2, 3, 4, 6, 6P, 12 and 13; IP67 (IEC529), 1200 psi (8270 kPa) washdown; micro connector versions also meet IP69K (IEC529)
Connection Type	Quick-Disconnect: 4-pin mini, 4-pin micro; Conduit Opening: 1/2 - 14NPT thread, PG 13.5 thread
LED	Green: Power, Orange: Output Energized
Operating Temperature [C (F)]	-25...+70 ° (-13...+158 °)
Shock	30 g, 11 ms
Vibration	55 Hz, 1 mm amplitude, 3 planes

Correction Factors

Target Material	Correction Factors
Steel	1.0
Stainless Steel	0.7...0.8
Brass	0.4...0.5
Aluminum	0.3...0.4
Copper	0.2...0.3

Rectangular Sensors 871F 4-Wire DC Complementary Output Flat Pack Style

Approximate Dimensions [mm (in.)]

Mini QD Style

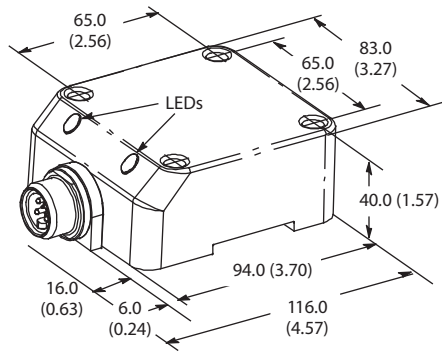

Micro QD Style

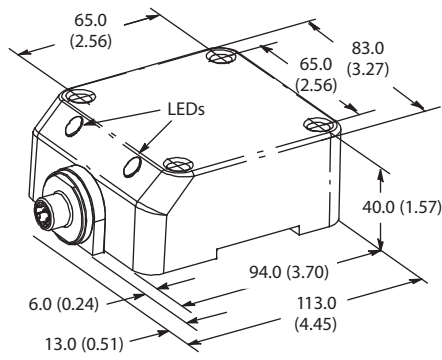

Conduit Style 1/2 in. NPT

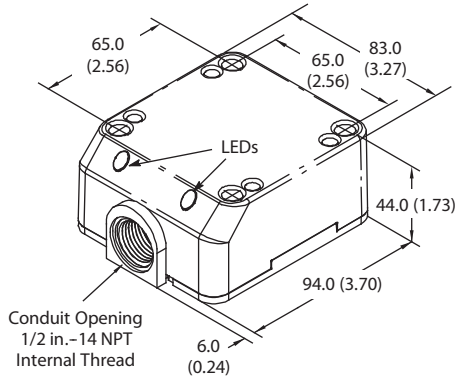

Conduit Style PG13.5

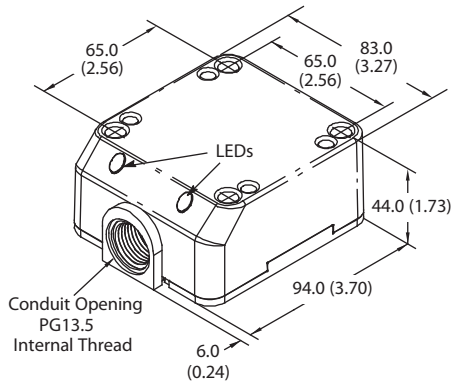

Wiring Diagrams

Complementary Normally Open and Normally Closed Outputs

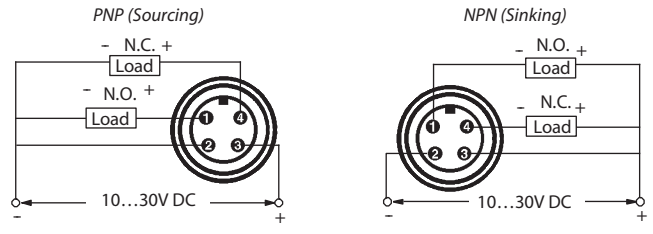

Complementary Normally Open and Normally Closed

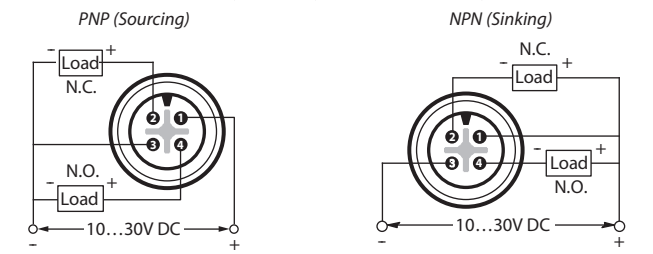

Complementary Normally Open and Normally Closed

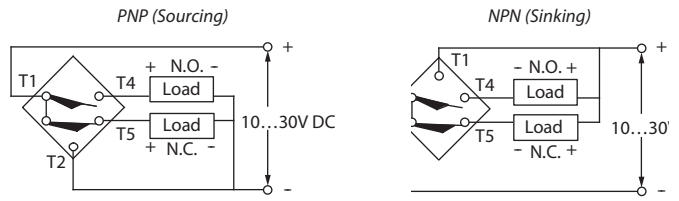

Complementary Normally Open and Normally Closed

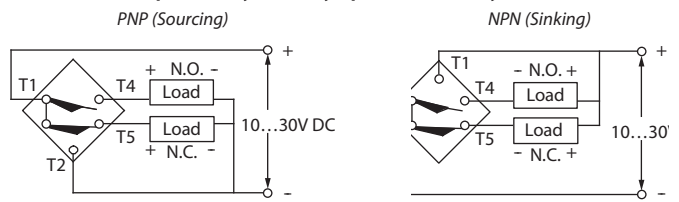

Rectangular Sensors

871F 2-Wire AC/DC

Flat Pack Style



871F AC/DC Cable Style



871F DC Mini Quick-Disconnect Style



871F DC Micro Quick-Disconnect Style

Specifications

Load Current, Max.	100 mA
Load Current, Min.	5 mA
Leakage Current	≤1.7 mA @ 120V; ≤2.0 mA @ 250V
Operating Voltage	20...250V AC/DC
Voltage Drop	≤10V
Repeatability	≤5%
Hysteresis	≤10% typical
Protection Type	False pulse, transient noise, short circuit, and overload
Certifications	cULus Listed and CE Marked for all applicable all directives
Enclosure Type Rating	NEMA 1, 2, 3, 4, 6, 6P, 12 and 13; IP67 (IEC529), 1200 psi (8270 kPa) washdown; micro connector versions also meet IP69K (IEC529)
Connection Type	Cable: 2 m (6.5 ft), 2-conductor #22 AWG ToughLink; Quick-Disconnect: 3-pin mini style, 3-pin micro style; Conduit Opening: 1/2 - 14NPT thread, PG 13.5 thread
LED	Green: Power, Orange: Output Energized
Operating Temperature [C (F)]	-25...+70 ° (-13...+158 °)
Shock	30 g, 11 ms
Vibration	55 Hz, 1 mm amplitude, 3 planes

Correction Factors

Target Material	Correction Factors
Steel	1.0
Stainless Steel	0.7...0.8
Brass	0.4...0.5
Aluminum	0.3...0.4
Copper	0.2...0.3

Approximate Dimensions [mm (in.)]

Cable Style

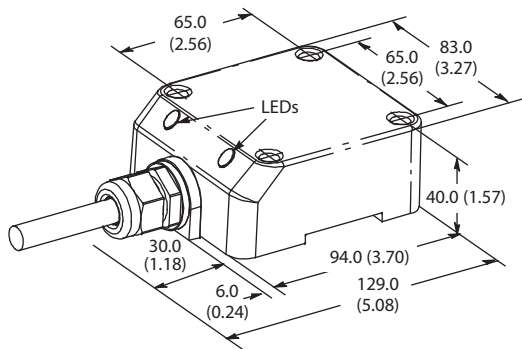

Wiring Diagrams

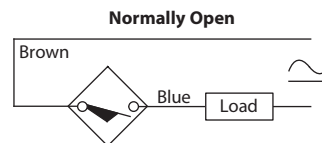

Note: Load can be switched to brown wire.

Approximate Dimensions [mm (in.)]

Mini QD Style

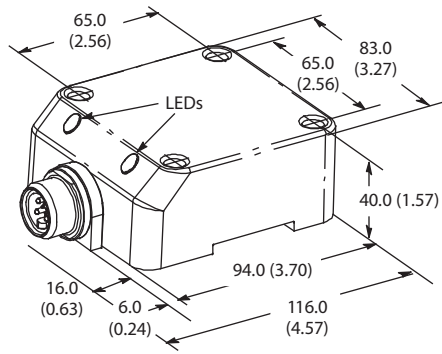

Micro QD Style

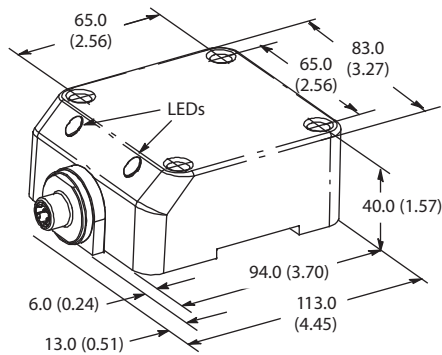

Conduit Style 1/2 in. NPT

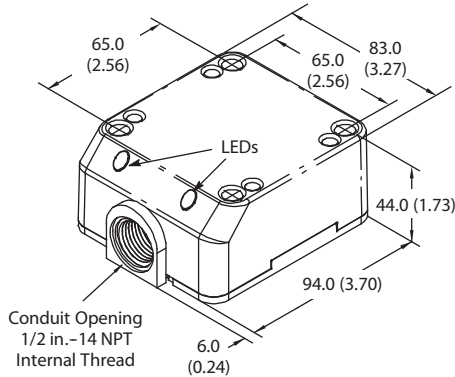

Conduit Style PG13.5

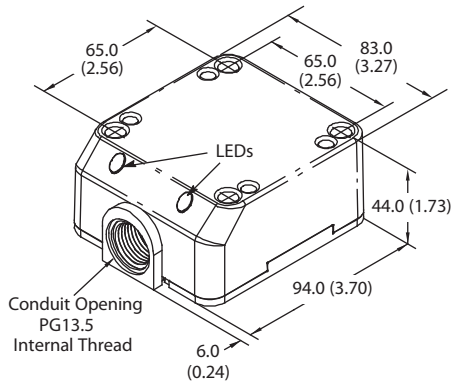

Wiring Diagrams

Normally Open

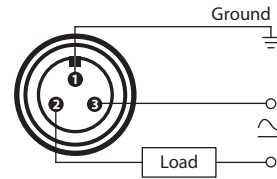

Note: Load can be switched to pin 3.

Normally Open

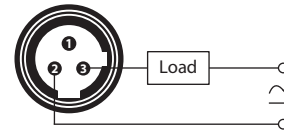

Note: Load can be switched to pin 2.

Normally Open

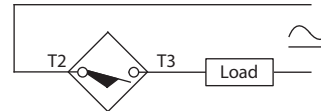

Note: Load can be switched to terminal 2.

Normally Open

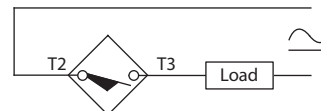

Note: Load can be switched to terminal 2.

Rectangular Sensors
871F DC Weld Field Immune
 Flat Pack Style



871F DC Mini
 Quick-Disconnect Style



871F DC Micro
 Quick-Disconnect Style

Specifications

Load Current	≤200 mA
Load Current, Min.	1 mA
Leakage Current	≤10 μA
Operating Voltage	10...30V DC
Voltage Drop	≤2.5V
Repeatability	≤5%
Hysteresis	≤5% typical
Protection Type	False pulse, transient noise, reverse polarity, short circuit, and overload
Weld Field Immunity	1600 Gauss
Certifications	cULus Listed and CE Marked for all applicable all directives
Enclosure Type Rating	NEMA 1, 2, 3, 4, 6, 6P, 12 and 13; IP67 (IEC529), 1200 psi (8270 kPa) washdown; micro connector versions also meet IP69K (IEC529)
Housing Material	Valox®
Connection Type	Quick Disconnect: 4-pin mini style, 4-pin micro style
LED	Green: Power, Orange: Output Energized
Operating Temperature [C (F)]	-25...+70 ° (-13...+158 °)
Shock	5 g
Vibration	55 Hz, 1 mm amplitude, 3 planes

Correction Factors

Target Material	Correction Factors
Steel	1.0
Stainless Steel	0.7...0.8
Brass	0.4...0.5
Aluminum	0.3...0.4
Copper	0.2...0.3

Approximate Dimensions [mm (in.)]

Mini QD Style

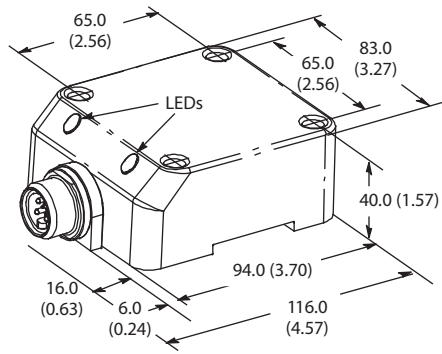

Micro QD Style

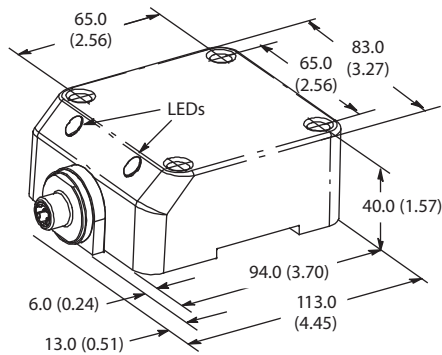

Wiring Diagrams

Complementary Normally Open and Normally Closed Outputs

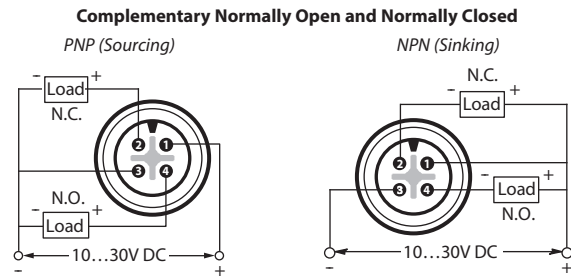
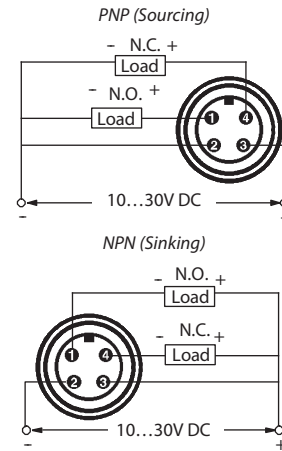

Rectangular Sensors

871F 2-Wire AC/DC Weld Field Immune

Flat Pack Style



Bul. 871F AC/DC WFI Micro
Quick-Disconnect Style

Specifications

Load Current	≤100 mA
Load Current, Min.	5 mA
Leakage Current	≤1.7 mA @ 120V; ≤2.0 mA @ 250V
Operating Voltage	20...250V AC/DC
Voltage Drop	≤10V
Repeatability	≤5%
Hysteresis	10% typical
Protection Type	False pulse, transient noise, short circuit, and overload
Weld Field Immunity	1600 Gauss
Certifications	cULus Listed and CE Marked for all applicable all directives
Enclosure Type Rating	NEMA 1, 2, 3, 4, 6, 6P, 12 and 13; IP67 (IEC529), 1200 psi (8270 kPa) washdown; micro connector versions also meet IP69K (IEC529)
Housing Material	Valox®
Connection Type	Quick Disconnect: 3-pin micro style
LED	Green: Power Red: Output energized
Operating Temperature [C (F)]	-25...+70 ° (-13...+158 °)
Shock	30 g, 11 ms
Vibration	55 Hz, 1 mm amplitude, 3 planes

Correction Factors

Target Material	Correction Factors	
	Shielded	Unshielded
Steel	1.0	1.0
Stainless Steel	0.7...0.8	0.7...0.8
Brass	0.5...0.6	0.4...0.5
Aluminum	0.4...0.5	0.4...0.5
Copper	0.4...0.5	0.4...0.5

Approximate Dimensions [mm (in.)]

Micro QD Style

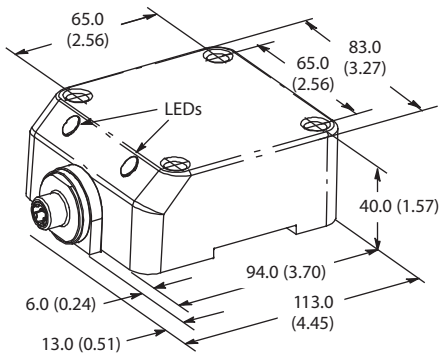

Wiring Diagrams

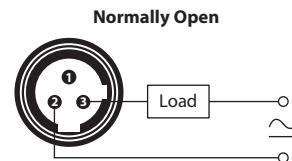



871F AC/DC Mini and Micro
 Quick-Disconnect Style

Specifications

Load Current	≤400 mA
Load Current, Min.	3 mA
Inrush Current (1 cycle)	≤8 A
Leakage Current	≤1.5 mA
Operating Voltage	20...250V AC/DC
Voltage Drop	≤5V
Repeatability	≤10%
Hysteresis	≤15% typical
Protection Type	Short circuit, false pulse, and transient noise
Weld Field Immunity	20,000 A at 1 inch
Certifications	CE Marked for all applicable directives
Enclosure Type Rating	NEMA 4 and 13, IP67 (IEC529)
Housing Material	Aluminum body, PTFE sensing area
Connection Type	Quick-Disconnect: 3-pin mini style, 3-pin micro style
LED	Green: Power, Orange: Output Energized
Operating Temperature [C (F)]	-25...+70 ° (-13...+158 °)
Shock	30 g, 11 ms
Vibration	55 Hz, 1 mm amplitude, 3 planes

Correction Factors

Target Material	Correction Factors
Steel	1.0
Stainless Steel	0.7...0.8
Brass	0.4...0.5
Aluminum	0.3...0.4
Copper	0.2...0.3

Approximate Dimensions [mm (in.)]

Mini QD Style

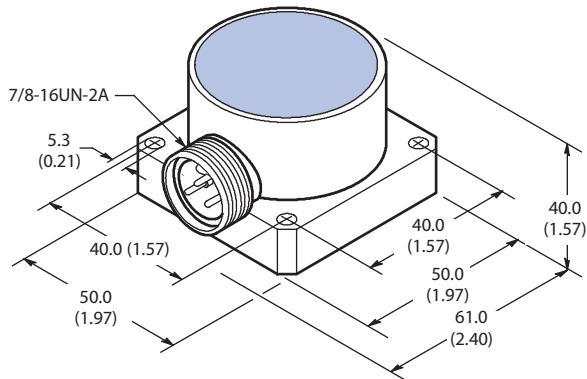

Micro QD Style

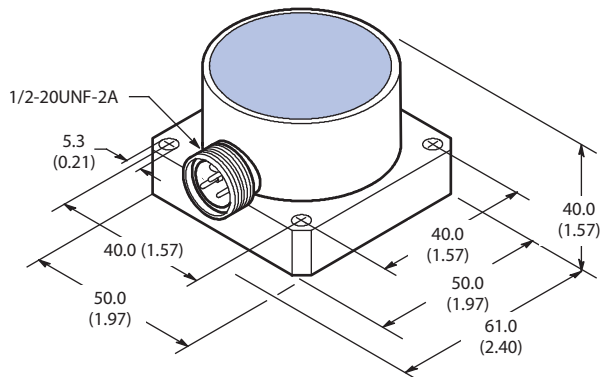

Wiring Diagrams

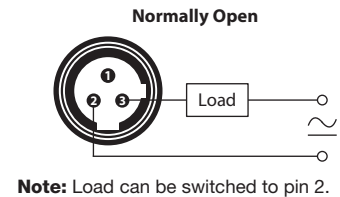
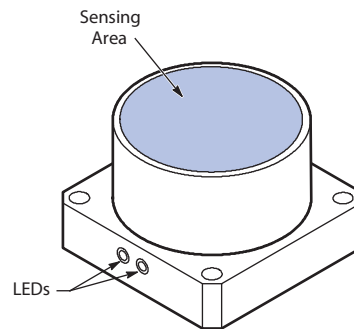
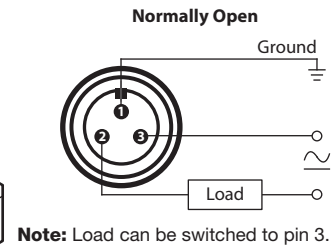
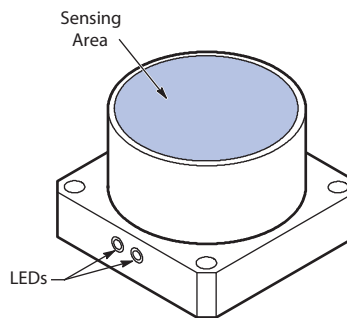

Rectangular Sensors

871FM 3-Wire DC

Miniature Flat Pack Style—Plastic Housing



871FM DC Cable Style
28 x 16 x 11 mm



871FM DC Cable Style
25 x 50 x 10 mm



871FM DC Cable Style
30 x 18 x 10 mm



871FM DC Pico
Quick-Disconnect Style
28 x 16 x 11 mm

Specifications

	28x16x11 mm	25x50x10 mm	31x18x10 mm
Current Consumption	<11 mA	<8 mA	10 mA
Load Current	≤200 mA	≤200 mA	50 mA @ 12V DC 100 mA @ 24V DC
Leakage Current	≤100 μA	≤100 μA	≤100 μA
Operating Voltage	10...30V DC	10...24V DC	10...30V DC
Voltage Drop	≤1.8V	≤2.5V	≤1V
Repeatability	≤5%		
Hysteresis	10% typical		
Protection Type	False pulse, transient noise, reverse polarity, short circuit, and overload		
Certifications	CE Marked for all applicable directives		
Enclosure Type Rating	NEMA 4; IP67 (IEC 529)		
Housing Material	Plastic		
Connection Type	Cable: 2 m (6.5 ft) length, 3-conductor PVC Quick-Disconnect: 3-pin pico style		
LED	Yellow: Output Energized	Red: Output Energized	
Operating Temperature [C (F)]	-25...+70 ° (-13...+158 °)		
Shock	30 g, 11 ms		50 g (approx)
Vibration	55 Hz, 1 mm amplitude, 3 planes		10...55Hz @ 1...5 mm

Correction Factors

Target Material	Correction Factors
Steel	1.0
Stainless Steel	0.85
Brass	0.55
Aluminum	0.5
Copper	0.45

Approximate Dimensions [mm (in.)]

Cable & Pico QD Style (28 x 16 x 11 mm)

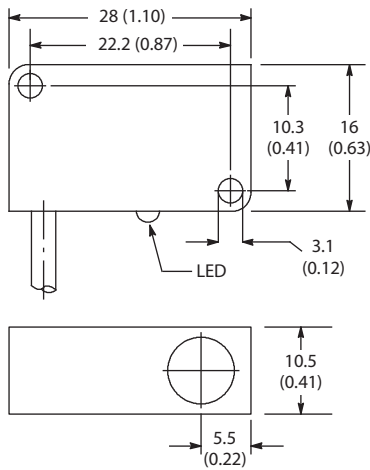

Wiring Diagrams

Cable Style (28 x 16 x 11 mm)

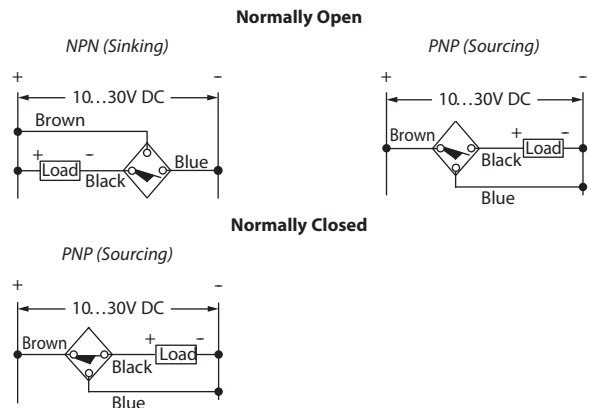

Pico QD Style (28 x 16 x 11 mm)

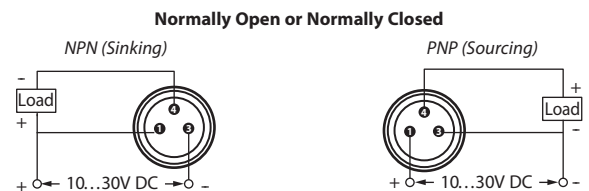

Rectangular Sensors 871FM 3-Wire DC Miniature Flat Pack Style—Plastic Housing

Approximate Dimensions [mm (in.)]

Unshielded Cable & Pico QD & Shielded Pico QD Style (25 x 50 x 10 mm)

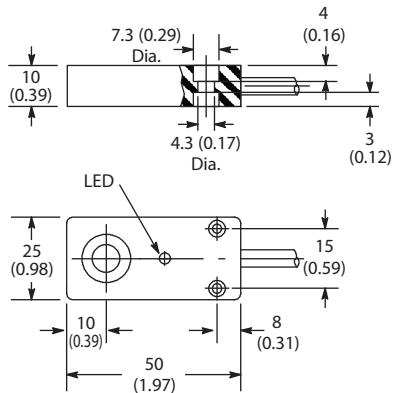

Shielded Cable Style (25 x 50 x 10 mm)

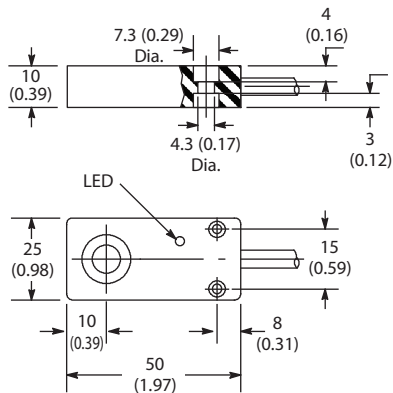

Cable Style (31 x 18 x 10 mm)

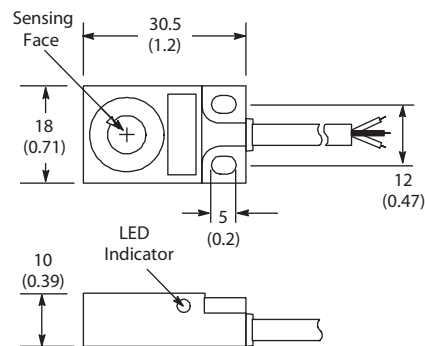

Wiring Diagrams

Cable Style (25 x 50 x 10 mm)

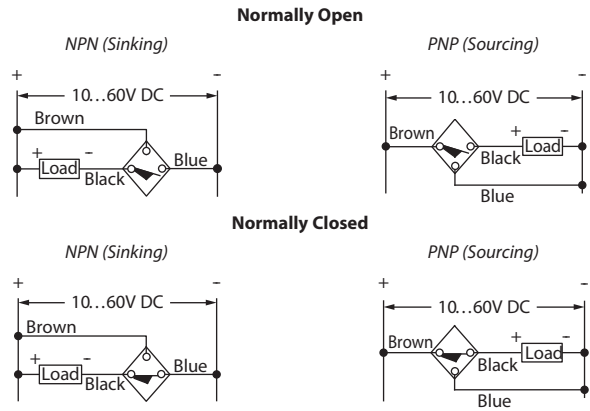

Pico QD Style (25 x 50 x 10 mm)

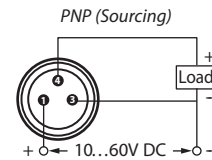

Cable Style (31 x 18 x 10 mm)

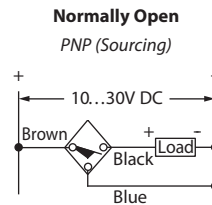

Rectangular Sensors
871FM 3-Wire DC
 Miniature Flat Pack Style—Metal Housing



871FM DC Pico
M8 Square



871FM DC Cable
M5 Square



Specifications

Certifications	UL Listed and CE Marked for all applicable directives
Environmental	
Operating Environment	IP67 (IEC 529)
Operating Temperature [C (F)]	-25...+70° (-13...+158°)
Vibration	10...55 Hz, 1 mm amplitude, 3 planes
Shock	30 g, 11 ms
Electrical	
Load Current	≤200 mA
Leakage Current	0.1 mA
Operating Voltage	10...30V DC
Voltage Drop	2.4V
Repeatability	10%
Hysteresis	12% typical
Protection Type	False pulse, transient noise, reverse polarity, and short circuit
IO-Link	
Protocol	IO-Link V1.0
Interface Type	IO-Link
Mode	COM 2 (38.4 kBaud)
Cycle Time	10.4 ms, minium
SIO (standard I/O)	Supported (pin 4 for either IO-Link or SIO)
Mechanical	
Housing Material	Nickel-plated brass, polyester face
LED (SIO mode)	Yellow: Output energized
LED (IO-Link Mode)	Solid yellow: Sensor in IO-Link mode
Connection Type	Cable, pico QD, or pico with lead

Correction Factors

Sensor Type/Target Material (No Surrounding Metal)	M5 Square	M8 Square	
	Shielded	Shielded	Unshielded
Steel	1	1	1
Copper	0.6	0.45	0.27
Aluminum	0.6	0.5	0.36
Brass	0.7	0.6	0.45
Stainless Steel 304	0.85	0.8	0.77

Switching Frequency

Head Size	Nominal Sensing Distance [mm (in.)]	Switching Frequency (Hz)
5 mm	0.8 (0.03)	5000
	1.5 (0.06)	3000
8mm	2.0 (0.08)	
	3.0 (.12)	1000

Rectangular Sensors
871FM 3-Wire DC
 Miniature Flat Pack Style—Metal Housing

Approximate Dimensions [mm (in.)]

Wiring Diagrams

M5 and M8 Square Cable

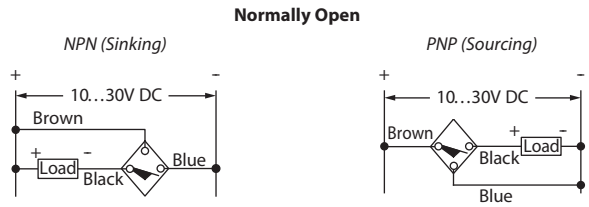
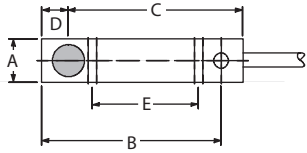

Housing Diameter	[mm (in.)]				
	A	B	C	D	E
5 mm	5.0 (0.2)	15 (0.59)	22 (0.87)	3 (0.12)	14 (0.55)
8 mm	8.0 (0.31)	37 (1.46)	35 (1.38)	5 (0.2)	20 (0.79)

M5 Square with 6 inch Lead

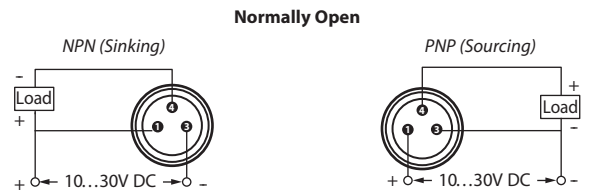
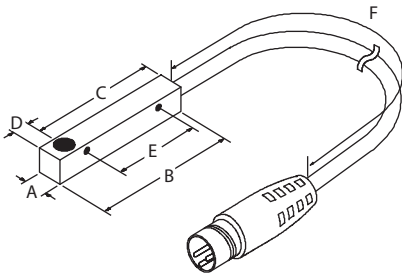

Housing Diameter	[mm (in.)]					
	A	B	C	D	E	F
5 mm	5.0 (0.2)	25 (0.98)	22 (0.87)	3 (0.12)	14 (0.55)	150 (6)

M8 Square 3-Pin Pico

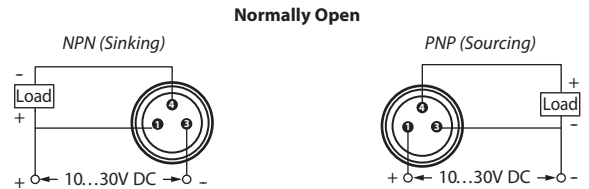
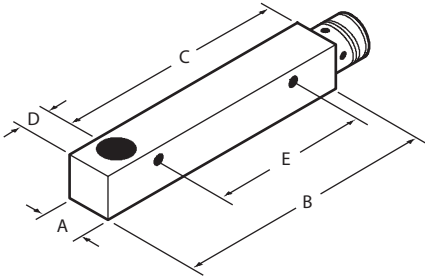

Housing Diameter	[mm (in.)]				
	A	B	C	D	E
8 mm	8.0 (0.31)	50 (1.97)	45 (1.77)	5 (0.2)	20 (0.79)

Rectangular Sensors

871L & 872L 3-Wire DC

Limit Switch Style



871L & 872L DC
Mini Quick-Disconnect Style



871L & 872L DC
Micro Quick-Disconnect Style



871L & 872L DC
Conduit Style

Specifications

	Bul. 871L Models	Bul. 872L Models
Load Current	≤400 mA	≤120 mA
Leakage Current	≤10 μA	
Operating Voltage	10...60V DC	10...30V DC
Voltage Drop	≤2.4V	≤2.5V
Repeatability	≤5%	
Hysteresis	≤20% typical	
Protection Type	False pulse, transient noise, reverse polarity, short circuit, and overload	
Certifications	cULus Listed and CE Marked for all applicable directives	
Enclosure Type Rating	NEMA 3, 4, 6, 12, 13; IP67 (IEC 529)	
Housing Material	Polyloy	
Connection Type	Quick-disconnect: 4-pin mini, 4-pin micro; Conduit Opening: 1/2-14 NPT internal thread with screw terminals	
Indicator LEDs	Green: Power (Blinks in SCP/Overload), Orange: Output Energized, Red: Alignment Indicator	Green: Power (Blinks in SCP/Overload), Orange: Output Energized
Operating Temperature [C (F)]	-25...+70 ° (-13...+158 °)	
Shock	30 g, 11 ms	
Vibration	55 Hz, 1 mm amplitude, 3 planes	

Correction Factors

Target Material	Correction Factor
Steel	1.0
Stainless Steel	0.7...0.8
Brass	0.4...0.5
Aluminum	0.3...0.4
Copper	0.2...0.3

Approximate Dimensions [mm (in.)]

Conduit Style

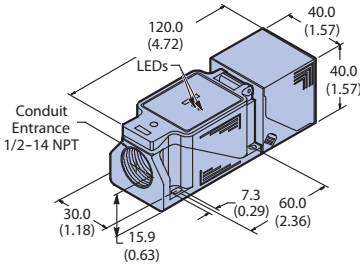

Mini QD Style

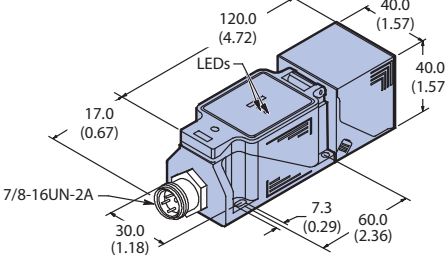

Micro QD Style

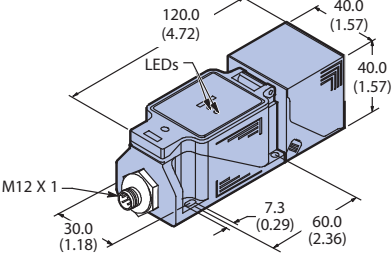

Note: Head can be rotated in 22.5° increments to provide 16 side-sensing positions or rotated for top-sensing.

Wiring Diagrams

Conduit Style

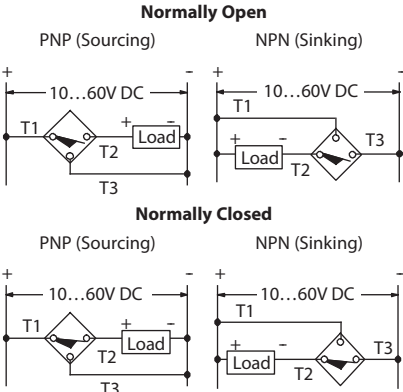

Mini QD Style

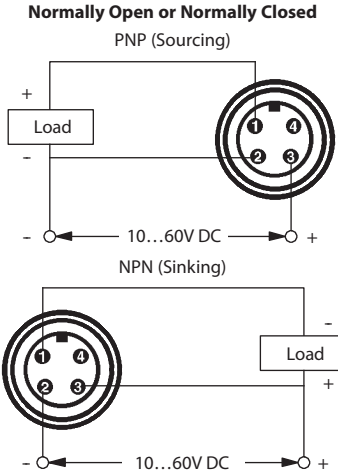

Micro QD Style

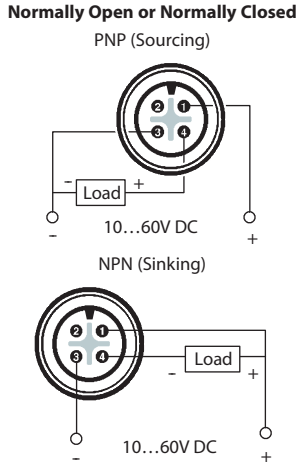

Rectangular Sensors
871L AC/DC & 872L AC 2-Wire
 Limit Switch Style



871L & 872L DC
 Mini Quick-Disconnect Style



871L & 872L DC
 Micro Quick-Disconnect Style



871L & 872L DC
 Conduit Style

Specifications

	Bul. 871L Models	Bul. 872L Models
Load Current	≤400 mA	≤500 mA
Load Current, Min.	2 mA	
Inrush Current (1 cycle)	≤8 A	
Leakage Current	≤2 mA	
Operating Voltage	20...250V AC/DC	20...250V AC
Voltage Drop	≤5V	
Repeatability	≤5%	
Hysteresis	≤20%	
Protection Type	False pulse & transient noise	
Certifications	cULus Listed and CE Marked for all applicable directives	
Enclosure Type Rating	NEMA 3, 4, 6, 12, 13; IP65 (IEC 529)	
Housing Material	Polyloy	
Connection Type	Quick Disconnect: 3-pin mini style, 3-pin micro style Conduit Opening: 1/2-14 NPT internal thread with screw terminals	
Indicator LEDs	Green: Power (Blinks in SCP/Overload), Orange: Output Energized	
Operating Temperature [C (F)]	-25...+70 ° (-13...+158 °)	
Shock	30 g, 11 ms	
Vibration	55 Hz, 1 mm amplitude, 3 planes	

Correction Factors

Target Material	Correction Factor
Steel	1.0
Stainless Steel	0.7...0.8
Brass	0.4...0.5
Aluminum	0.3...0.4
Copper	0.2...0.3

Approximate Dimensions [mm (in.)]

Conduit Style

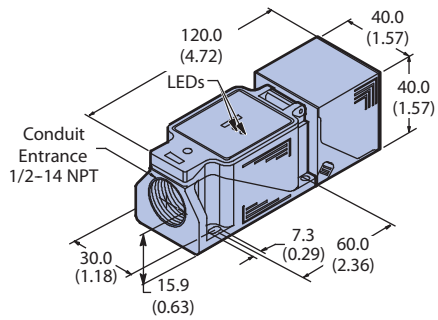

Mini QD Style

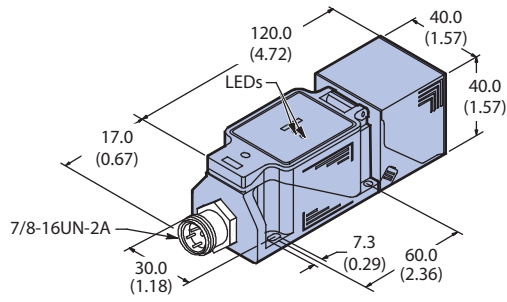

Micro QD Style

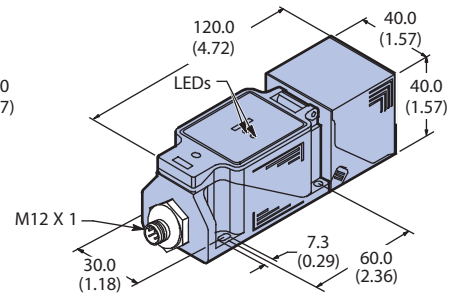

Note: Head can be rotated in 22.5° increments to provide 16 side-sensing positions or rotated for top-sensing.

Wiring Diagrams

Conduit Style

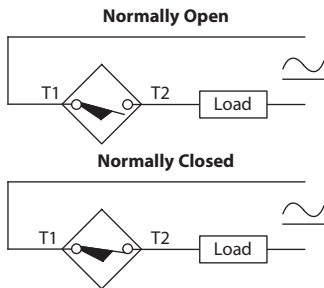

Mini QD Style

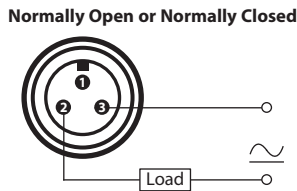

Note: Load can be switched to pin 3.

Micro QD Style

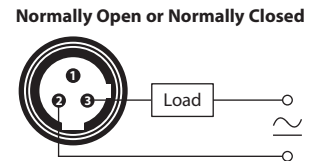

Note: Load can be switched to pin 2.

Note: Load can be switched to terminal 1.

Rectangular Sensors

871P 2-Wire AC

Can Sensors



871P AC Long-Range
76 x 36 x 58 mm

Specifications

Load Current, Max.	300 mA
Load Current, Min.	15 mA
Leakage Current	<1.5 mA
Inrush Current	<5 A (20 ms)
Operating Voltage	30...150V AC RMS
Line Frequency	40...60 Hz
Voltage Drop	<15V @ 300 mA
Repeatability	≤2%
Hysteresis	10% typical
Protection Type	False pulse, transient noise, short circuit, and overload
Certifications	UL Listed and CE Marked for all applicable directives
Enclosure Type Rating	NEMA 1, 3, 4, 4X, 6, 6P, 12, 13; IP67 (IEC 529), 1200 psi (8270 kPa) washdown
Connection Type	3-pin mini style
LED	Red: Output Energized
Operating Temperature [C (F)]	-20...+70 ° (0...+160 °)
Housing Material	Stainless steel, plastic face
Mounting	2 stainless steel studs

Approximate Dimensions [mm (in.)]

Long-Range Mini QD Style

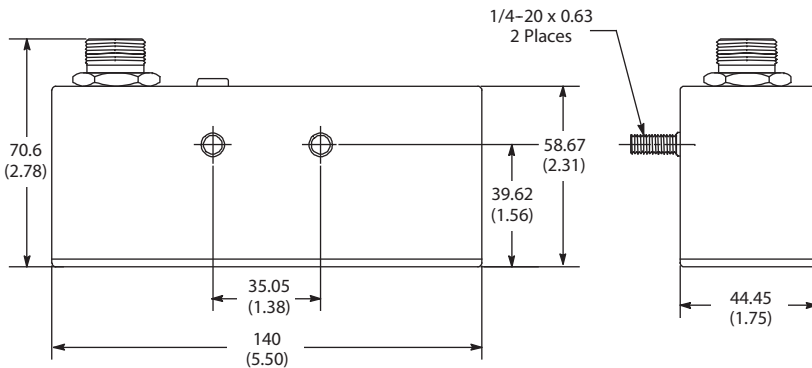

Wiring Diagrams

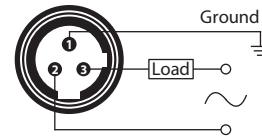

Note: Load can be switched to pin 2.



871P DC Short Range
 76 x 36 x 58 mm

Specifications

Load Current	300 mA
Operating Voltage	10...30V DC
Operating Current	25 mA (off), 55 mA (on)
Voltage Drop	≤2.5V
Repeatability	≤2%
Hysteresis	3...15%
Protection Type	False pulse, transient noise, short circuit, overload, and reverse polarity
Enclosure Type Rating	NEMA 1, 3, 4, 4X, 6, 6P, 12, 13; IP67 (IEC 529), 1200 psi (8270 kPa) washdown
Connection Type	A2: 2 m shielded PVC jacketed cable, 4-wire, #22 AWG, 1/2 in. NPT N4: 4-pin mini quick-disconnect
LED	Red: Output energized
Operating Temperature [C (F)]	-20...+70 ° (0...+160 °)
Housing Material	Stainless steel, plastic face
Mounting	2 stainless steel studs

Approximate Dimensions [mm (in.)]

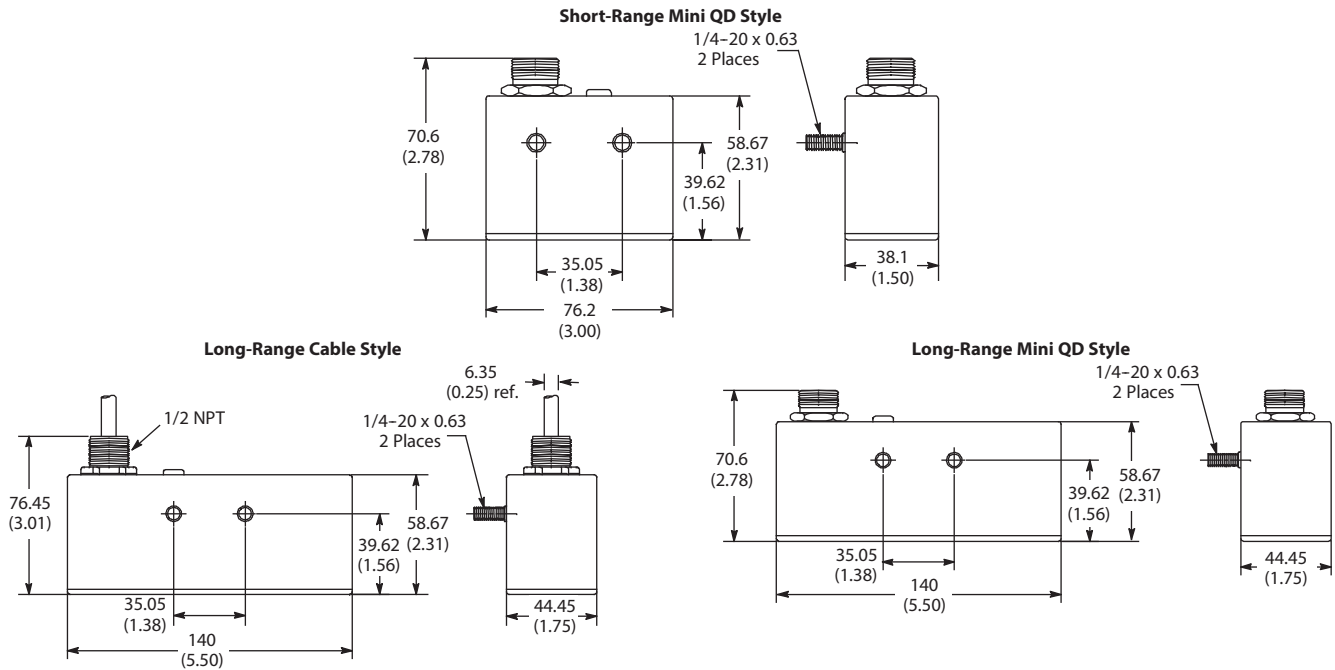

Wiring Diagrams

Cable Style

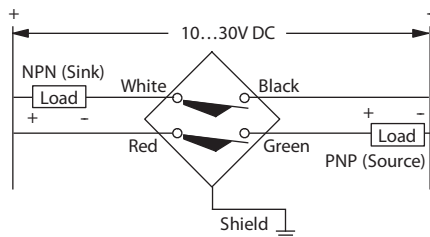

ATTENTION
 Red and black wires must be connected for proper operation.

Mini QD Style

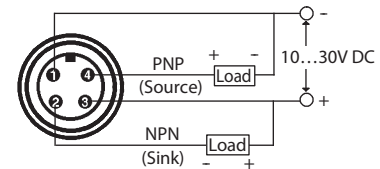

Rectangular Sensors

871P 4-Wire DC Motion

Can Sensors



871P DC Motion Style
140 x 45 x 58 mm

Specifications

Load Current	300 mA
Operating Voltage	10...30V DC
Operating Current	25 mA (off), 55 mA (on)
Voltage Drop	≤2.5V
Repeatability	≤2%
Hysteresis	3...15%
Output Time Delay	0.5 s after motion stops
Protection Type	False pulse, transient noise, short circuit, overload, and reverse polarity
Enclosure Type Rating	NEMA 1, 3, 4, 4X, 6, 6P, 12, 13; IP67 (IEC 529), 1200 psi (8270 kPa) washdown
Connection Type	A2: 2 m shielded PVC jacketed cable, 4-wire, #22 AWG, 1/2 in. NPT N4: 4-pin mini quick-disconnect D4: 4-pin micro quick-disconnect
LED	Red: Output Energized, Dim Blink: Cans moving, Bright Steady: No motion
Sensitivity Adjustment	Sensing range adjust
Operating Temperature [C (F)]	-20...+70 ° (0...+160 °)
Housing Material	Stainless steel, plastic face
Mounting	2 stainless steel studs

Approximate Dimensions [mm (in.)]

Cable Style

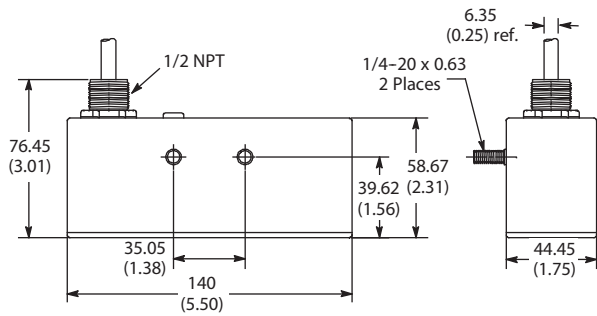

Wiring Diagrams

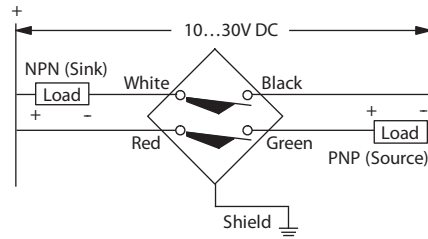

Mini and Micro QD Style

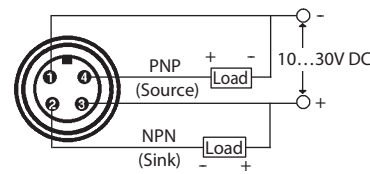
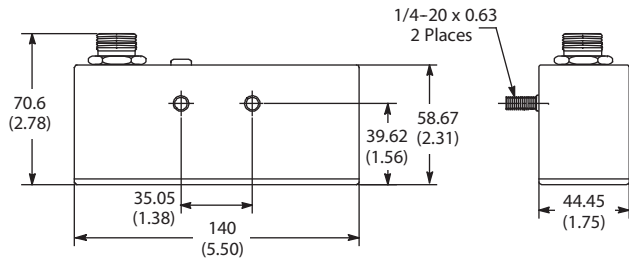



871P DC Micro Quick-Disconnect Style



871P DC Mini Quick-Disconnect Style

Specifications

Load Current	≤200 mA
Leakage Current	≤10 μA
Operating Voltage	10...60V DC
Voltage Drop	<2.5V @ 200 mA
Repeatability	≤5%
Hysteresis	5% typical
Protection Type	False pulse, transient noise, short circuit, overload, and reverse polarity
Certifications	cULus Listed and CE Marked for all applicable directives
Enclosure Type Rating	NEMA 1, 2, 3, 4, 6, 6P, 12, 13; IP67 (IEC 529), 1200 psi (8270 kPa) washdown; micro connector versions also meet IP69K (IEC 529)
Housing Material	Plastic body, zinc base
Connection Type	Quick Disconnect: 4-pin mini style, 4-pin micro style
Indicator LEDs	Orange: Output Energized; Green: Power
Operating Temperature [C (F)]	-25...+70 ° (-13...+158 °)
Shock	30 g, 11 ms
Vibration	55 Hz, 1 mm amplitude, 3 planes

Correction Factors

Target Material	Correction Factor
Steel	1.0
Stainless Steel	0.7...0.8
Brass	0.4...0.5
Aluminum	0.3...0.4
Copper	0.2...0.3

Approximate Dimensions [mm (in.)]

Mini QD Style

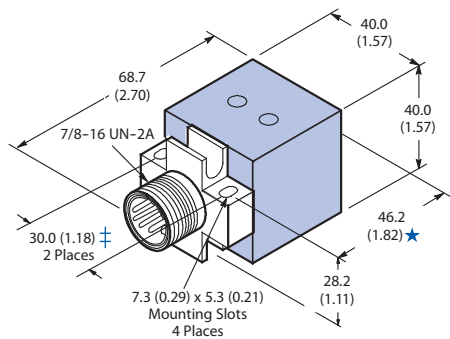

Micro QD Style

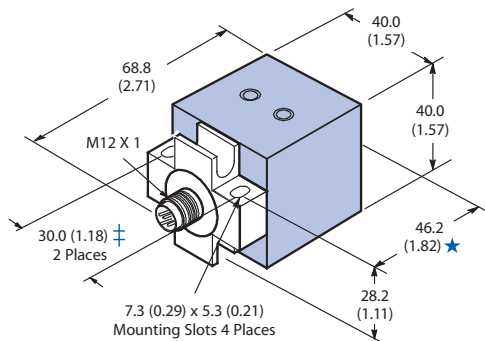

★ With retrofit adaptor, distance from face to mounting holes becomes 60.0 (2.36).
 ‡ With retrofit adaptor, spacing between mounting holes becomes 20.0 (0.79).

Wiring Diagrams

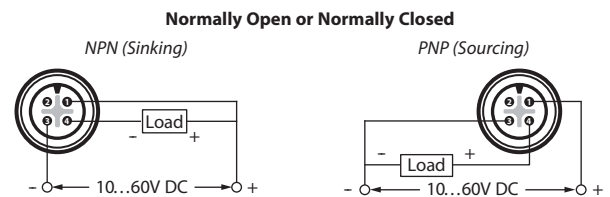
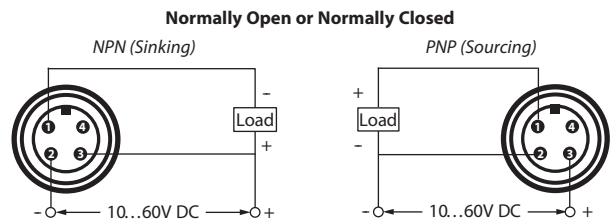

ATTENTION

Unit must be mounted to a grounded metal frame or grounded via field wiring lug per NEC requirements. Recommended grounding lug is available in Allen-Bradley mounting kit Cat. No. 871A-PKIT.

Rectangular Sensors
871P VersaCube™ 4-Wire DC
 General Purpose



871P DC Micro Quick-Disconnect Style
 (Standard Zinc Mounting Bracket)



871P DC Micro Quick-Disconnect Style
 (Optional Stainless Steel Mounting L-Bracket)

Specifications

Load Current	≤200 mA from -25...+50 °C (-13...+122 °F) ≤100 mA from 50...70 °C (122...158 °F)
Leakage Current	≤10 μA
Operating Voltage	10...30V DC
Voltage Drop	<2.5V @ 200 mA
Repeatability	≤10%
Hysteresis	10% typical
Protection Type	False pulse, transient noise, short circuit, overload, and reverse polarity
Weld Field Immunity	1000 Gauss
Certifications	cULus Listed and CE Marked for all applicable directives
Enclosure Type Rating	NEMA 1, 2, 3, 4, 6, 6P, 12, 13; IP67 (IEC 529), IP68, IP69k, 1200psi (8270kPa) wash-down; Plastic body, zinc bracket, optional stainless steel L-bracket
Connection Type	Quick Disconnect: 4-pin micro style
Indicator LEDs	Power: Green Output energized: Amber Margin indication: Amber flashing (target within 80...100% of operating distance) Short circuit or overload: Green and amber flashing
Operating Temperature [C (F)]	-25...+70 ° (-13...+158 °)
Shock	30 g, 11 ms
Vibration	55 Hz, 1 mm amplitude, 3 planes

Note: Bul. 871P VersaCube is offered with ToughCoat Weld Slag Finish on the sensor face. This is a proprietary epoxy-based material which resists the adhesion and accumulation of weld-slag particles thereby improving and extending sensor performance.

Correction Factors

Target Material	Correction Factor
Steel	1.0
Stainless Steel	1.0
Brass	1.0
Aluminum	1.0
Copper	1.0

Approximate Dimensions [mm (in.)]

Zinc Bracket

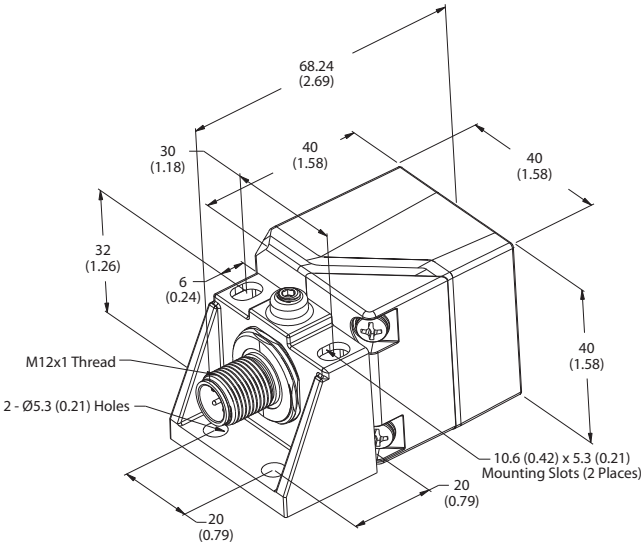

No Bracket

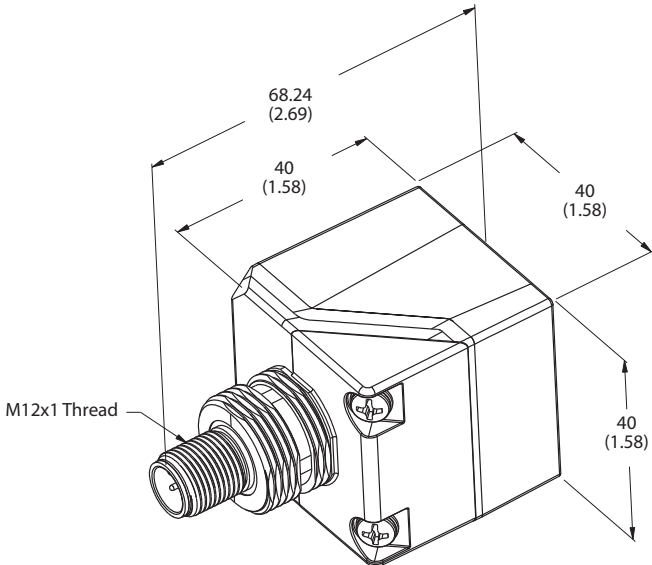

L-Bracket

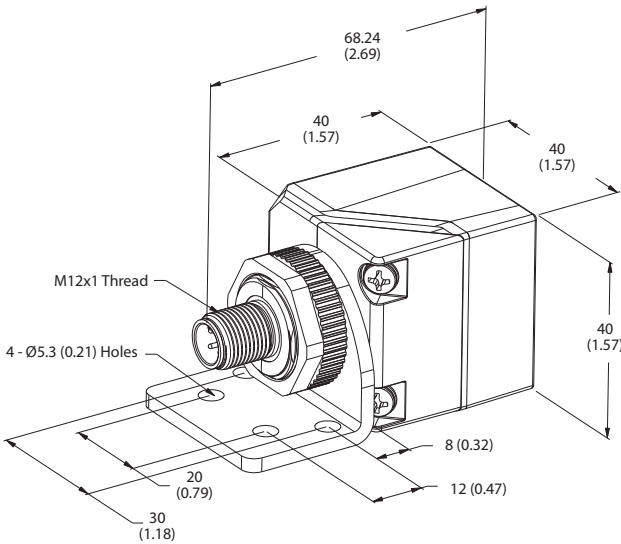

Wiring Diagrams

Micro QD Style

Complementary Normally Open and Normally Closed

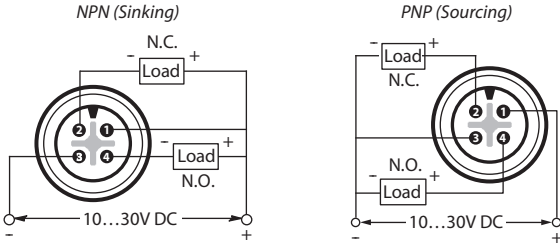

Rectangular Sensors

871P VersaCube™ 2-Wire AC/DC

General Purpose



871P AC/DC General Purpose
Micro Quick-Disconnect Style

Specifications

Load Current	2...100 mA
Inrush Current	≤2 A
Leakage Current	≤1.5 mA @ 20V, ≤1.7 mA @ 120V, ≤2.0 mA @ 250V
Operating Voltage	20...250V AC/DC
Voltage Drop	<10V
Repeatability	≤10% of effective operating distance
Hysteresis	12% typical
Protection Type	False pulse, transient noise, short circuit, and overload
Certifications	cULus Listed and CE Marked for all applicable directives
Enclosure Type Rating	NEMA 1, 2, 3, 4, 6, 6P, 12, 13; IP67 (IEC 529), 1200 psi (8270 kPa) washdown; micro connector versions also meet IP69K (IEC 529)
Housing Material	Plastic body, zinc base
Connection Type	Quick Disconnect: 3-pin mini style, 3-pin micro style
Indicator LEDs	Red: Output Energized, Green: Power (short circuit if flashing)
Operating Temperature [C (F)]	-25...+70 ° (-13...+158 °)
Shock	30 g, 11 ms
Vibration	55 Hz, 1 mm amplitude, 3 planes

Correction Factors

Target Material	Correction Factor
Steel	1.0
Stainless Steel	0.7...0.8
Brass	0.4...0.5
Aluminum	0.3...0.4
Copper	0.2...0.3

Approximate Dimensions [mm (in.)]

Mini QD Style

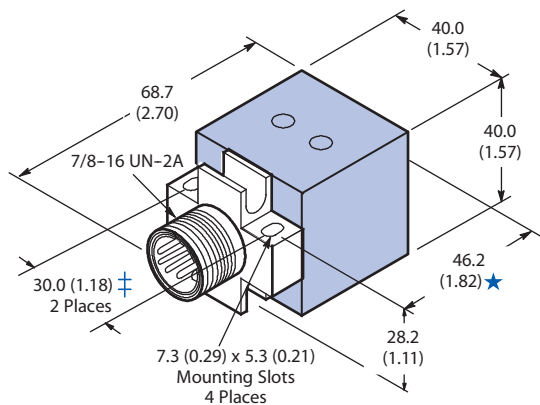

Micro QD Style

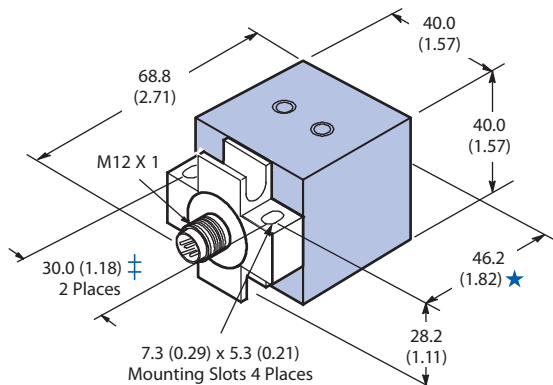

★ With retrofit adaptor, distance from face to mounting holes becomes 60.0 (2.36).
‡ With retrofit adaptor, spacing between mounting holes becomes 20.0 (0.79).

Wiring Diagrams

Normally Open or Normally Closed

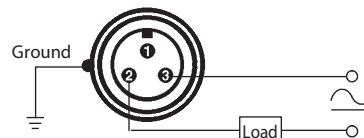

Note: Load can be switched to pin 3.

ATTENTION



Unit must be mounted to a grounded metal frame or grounded via field wiring lug per NEC requirements. Recommended grounding lug is available in Allen-Bradley mounting kit Cat. No. 871A-PKIT.

Normally Open or Normally Closed

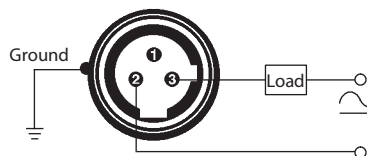

Note: Load can be switched to pin 2.



871P DC Micro Quick-Disconnect Style



871P DC Mini Quick-Disconnect Style

Specifications

Load Current	≤200 mA
Leakage Current	≤10 μA
Operating Voltage	10...60V DC
Voltage Drop	<2.5V @ 200 mA
Repeatability	≤10% of effective operating distance
Hysteresis	12% typical
Protection Type	False pulse, transient noise, short circuit, overload, and reverse polarity
Weld Field Immunity	1000 Gauss ‡
Certifications	UL Listed, cUL Certified, and CE Marked for all applicable directives
Enclosure Type Rating	NEMA 1, 2, 3, 4, 6, 6P, 12, 13; IP67 (IEC 529), 1200 psi (8270 kPa) washdown; micro connector versions also meet IP69K (IEC 529)
Housing Material	Plastic body, zinc base
Connection Type	Quick Disconnect: 4-pin mini style, 4-pin micro style
Indicator LEDs	Orange: Output Energized; Green: Power
Operating Temperature [C (F)]	-25...+70 ° (-13...+158 °)
Shock	30 g, 11 ms
Vibration	55 Hz, 1 mm amplitude, 3 planes

‡ Measured with field perpendicular to face.

Correction Factors

Target Material	Correction Factor
Steel	1.0
Stainless Steel	0.7...0.8
Brass	0.4...0.5
Aluminum	0.3...0.4
Copper	0.2...0.3

Approximate Dimensions [mm (in.)]

Mini QD Style

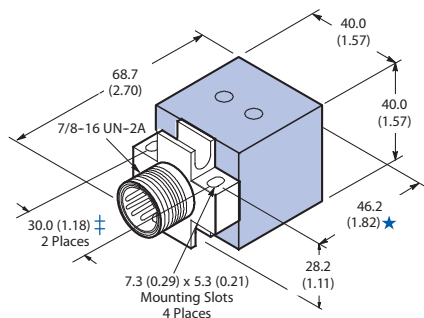

Micro QD Style

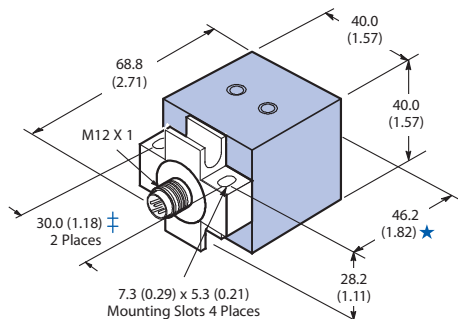

★ With retrofit adaptor, distance from face to mounting holes becomes 60.0 (2.36).
 ‡ With retrofit adaptor, spacing between mounting holes becomes 20.0 (0.79).

Wiring Diagrams

Mini QD Style

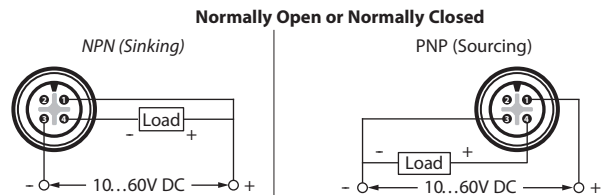
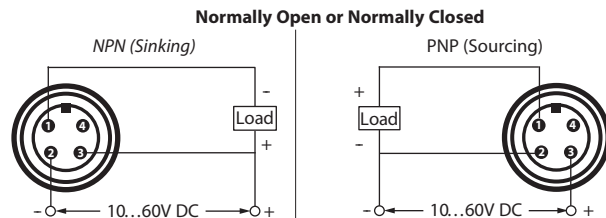

ATTENTION



Unit must be mounted to a grounded metal frame or grounded via field wiring lug per NEC requirements. Recommended grounding lug is available in Allen-Bradley mounting kit Cat. No. 871A-PKIT.

Cylinder Sensors

871D 3-Wire DC

Cylinder Position Inductive Style



871D DC Mini
Quick-Disconnect Style
12 mm



871D DC Micro
Quick-Disconnect Style
12 mm

Specifications

Outputs	Normally Open
Load Current, Max.	<200 mA
Load Current, Nom.	≤10 mA (non-activated), ≤18 mA (activated)
Leakage Current	<80 μA
Operating Voltage	10...30V DC
Voltage Drop	< 2.5V DC @ 200 mA
Switching Frequency [Hz]	10
Repeatability	5% typical
Hysteresis	15% typical
Protection Type	Reverse polarity, false pulse, transient noise, short circuit, and overload
Weld Field Immunity	20,000 A @ 1 in.
Certifications	cULus Listed and CE Marked for all applicable directives
Enclosure Type Rating	NEMA 1, 2, 3, 3R, 4, 6, 12, 13; IP67 (IEC 529)
Connection Type	Quick Disconnect: 4-pin mini style, 4-pin micro style
LED	Green: Power; Orange: Output
Operating Temperature [C (F)]	-25...+70 ° (-13...+158 °)
Shock	30 g, 11 ms
Vibration	55 Hz, 1 mm amplitude, 3 planes
Housing Material	Machined aluminum
Probe Material	Stainless steel, ceramic face

Approximate Dimensions [mm (in.)]

Mini Connector Models

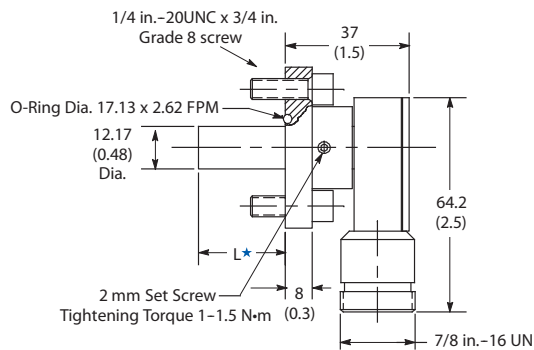
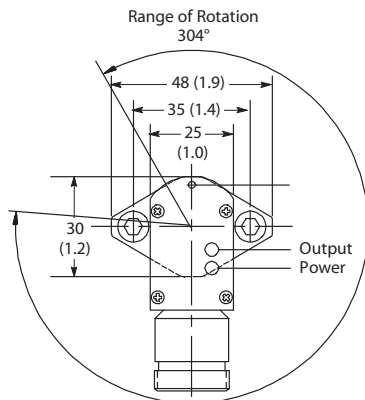

Wiring Diagrams

Mini Quick-Disconnect Style

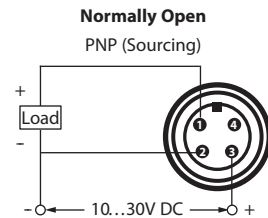

Micro Connector Models

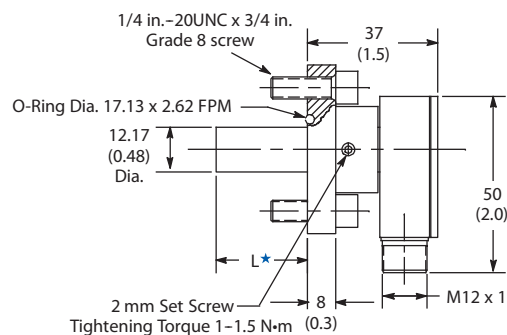
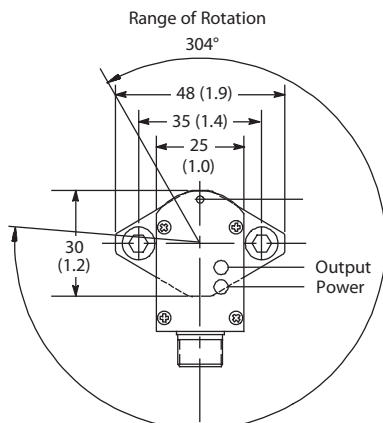

Micro Quick-Disconnect Style

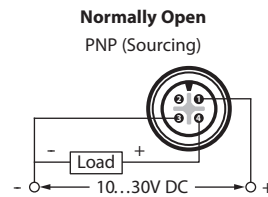

L* = Probe length varies by catalog number. See Product Selection tab on <http://ab.rockwellautomation.com>



871D DC Mini
Quick-Disconnect Style
12 mm



871D DC Micro
Quick-Disconnect Style
12 mm

Specifications

Outputs	Normally Open
Load Current	5...400 mA
Inrush Current (1 cycle)	<3 A (t < 20 msec)
Leakage Current	<1.7 mA @ 120V AC
Operating Voltage	20...250V AC/DC
Voltage Drop	<6V @ 400 mA
Switching Frequency [Hz]	50
Repeatability	5% typical
Hysteresis	15% typical
Protection Type	False pulse, transient noise, short circuit, and overload
Weld Field Immunity	20,000 A @ 1 in.
Certifications	cULus Listed and CE Marked for all applicable directives
Enclosure Type Rating	NEMA 1, 2, 3, 3R, 4, 6, 12, 13; IP67 (IEC 529)
Connection Type	Quick Disconnect: 3-pin mini style, 3-pin micro style
LED	Green: Power; Orange: Output
Operating Temperature [C (F)]	-25...+70 ° (-13...+158 °)
Shock	30 g, 11 ms
Vibration	55 Hz, 1 mm amplitude, 3 planes
Housing Material	Nickel plated brass
Probe Material	Stainless steel, ceramic face

Approximate Dimensions [mm (in.)]

Mini Connector Models

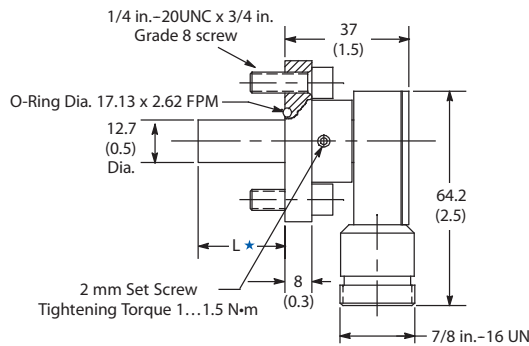
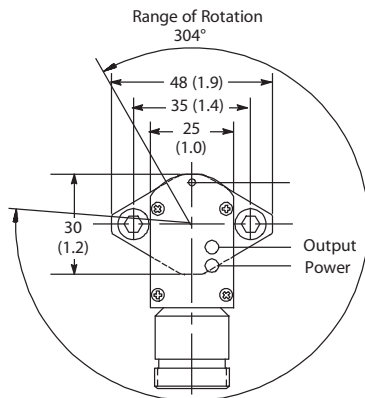

Wiring Diagrams

Mini Quick-Disconnect Style

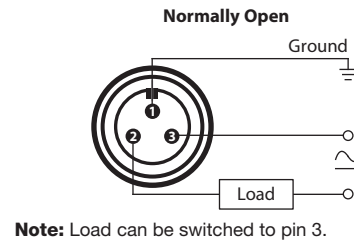

Micro Connector Models

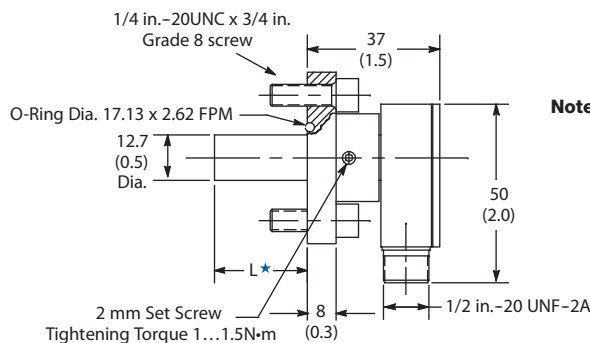
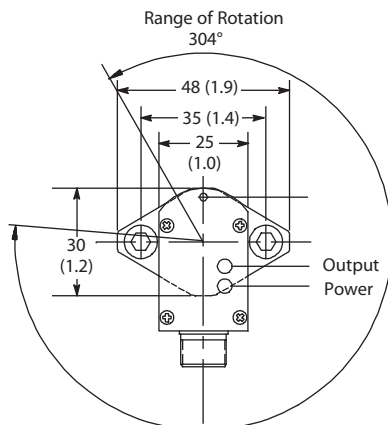

Micro Quick-Disconnect Style

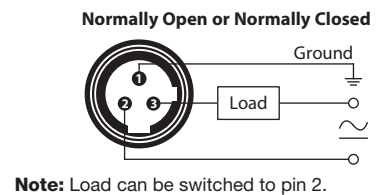

L★ = Probe length varies by catalog number. See Product Selection tab on <http://ab.rockwellautomation.com>

Cylinder Sensors

871D DC WorldClamp™

Power Clamp and Gripper Style



Bul. 871D DC — Small Chicklet
100, 165, and 200 mm



Bul. 871D DC — Large Chicklet
100, 165, and 200 mm



Bul. 871D DC — Cylindrical Chicklet
100 mm

Specifications

Load Current	150 mA max
Leakage Current	<10 μ A
Operating Voltage	10...30V DC
Voltage Drop	<2.5V
Repeatability	<2%
Hysteresis	5% typical
Protection Type	False pulse, transient noise, short circuit, and overload
Weld Field Immunity	1600 Gauss
Certifications	cULus Listed and CE Marked for all applicable directives
Enclosure Type Rating	IP67
Connection Type	4-pin micro quick-disconnect
LED	Green: power; orange: S1 output; red: S2 output
Operating Temperature [C (F)]	-25...+70 ° (-13...+158 °)
Shock	30 g, 11 ms
Vibration	55 Hz, 1 mm amplitude, 3 planes

Approximate Dimensions [mm (in.)]

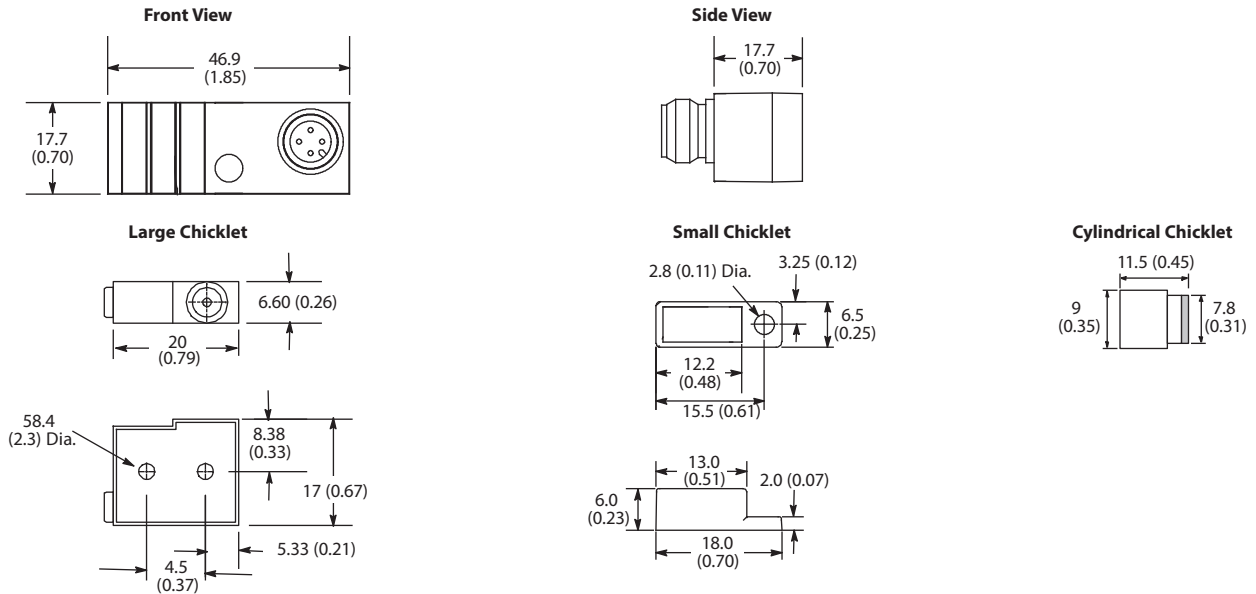

Wiring Diagrams

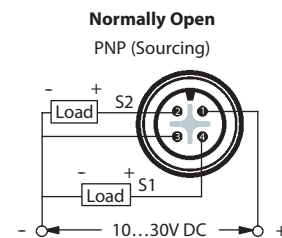



Bul. 871D AC/DC — Small Chicklet
 100, 165, and 200 mm



Bul. 871D AC/DC — Large Chicklet
 100, 165, and 200 mm

Specifications

Load Current	100 mA max
Inrush Current	≤2 A (1 cycle)
Leakage Current	<1.7 mA
Operating Voltage	20...150V AC/DC
Voltage Drop	<10V
Repeatability	<2%
Hysteresis	5% typical
Protection Type	False pulse, transient noise, short circuit, and overload
Weld Field Immunity	1600 Gauss
Certifications	cULus Listed and CE Marked for all applicable directives
Enclosure Type Rating	IP67
Connection Type	5-pin AC micro quick-disconnect
LED	2 green: power S1 and S2; orange: S1 output; red: S2 output
Operating Temperature [C (F)]	-25...+70 ° (-13...+158 °)
Shock	30 g, 11 ms
Vibration	55 Hz, 1 mm amplitude, 3 planes

Approximate Dimensions [mm (in.)]

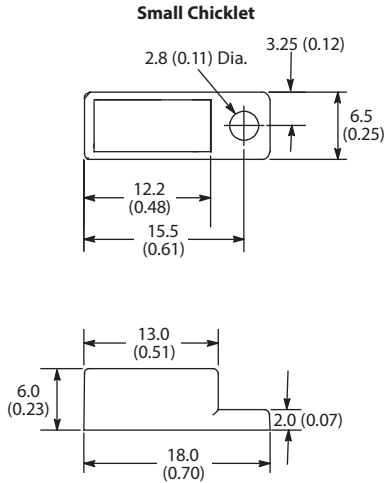
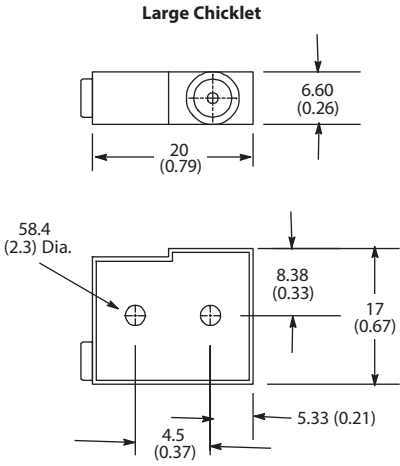
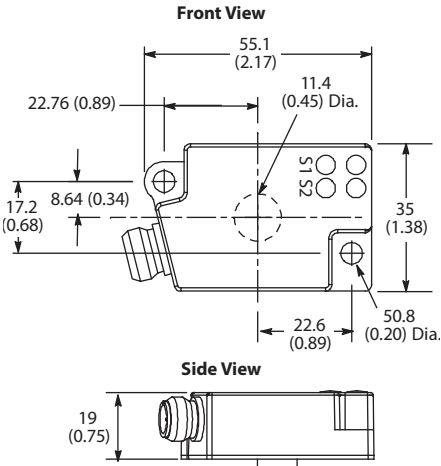

Wiring Diagrams

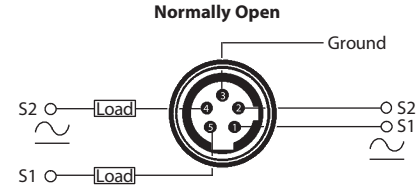

Note: Load can be switched to pin 1 (S1) and pin 2 (S2).

Ring & Slot Sensors

Bulletin 871R 3-Wire DC

Ring Style



871R DC Cable Style
12 & 20 mm



871R DC Micro
Quick-Disconnect Style
50 mm

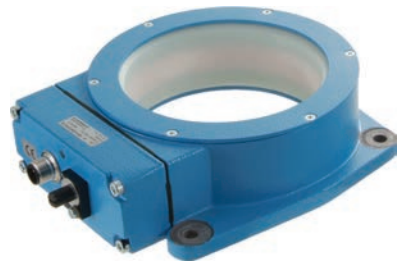

871R DC Micro
Quick-Disconnect Style
100 mm

Specifications

Load Current	≤200 mA
Leakage Current	≤10 μA
Operating Voltage	10...30V DC
Voltage Drop	≤2.4V
Repeatability	≤2%
Hysteresis	10% typical
Protection Type	Reverse polarity, transient noise, short circuit, overload, and false pulse
Certifications	CE Marked for all applicable directives
Enclosure Type Rating	NEMA 4, IP67 (IEC 529)
Connection Type	Cable: 2 m (6.5 ft.) length 3-conductor #26 AWG PVC Quick-Disconnect: 4-pin micro style
Indicator LEDs	Red: Output energized
Operating Temperature [C (F)]	-25...+70 ° (-13...+158 °)
Shock	5 g
Vibration	10...55 Hz

Approximate Dimensions [mm (in.)]

Cable Style (Cat. No. 871R-D12NP39-E2)

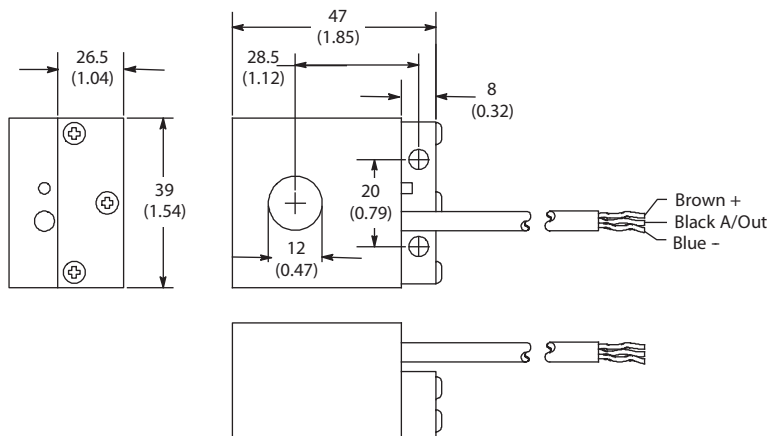

Wiring Diagrams

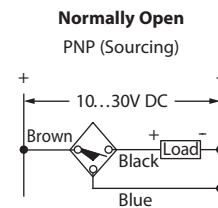

Approximate Dimensions [mm (in.)]

Wiring Diagrams

Cable Style (Cat. No. 871R-D20NP73-E2)

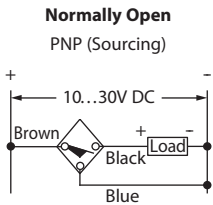
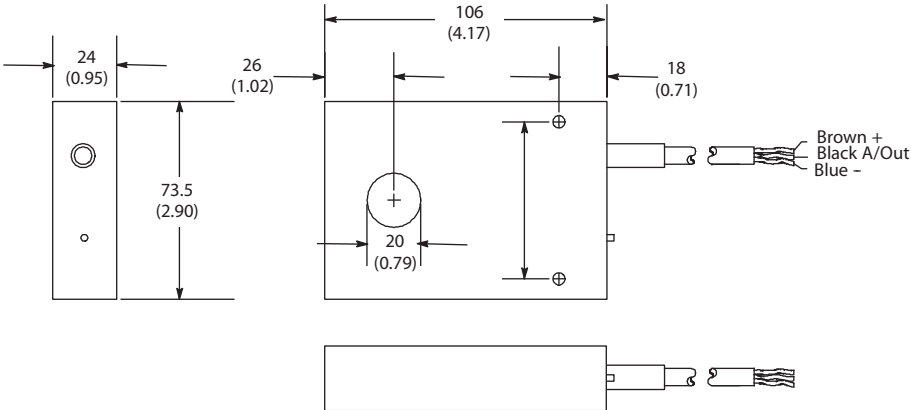

Micro Quick-Disconnect Style (871R-D50NP90-D4 & 871R-D50NN90-D4)

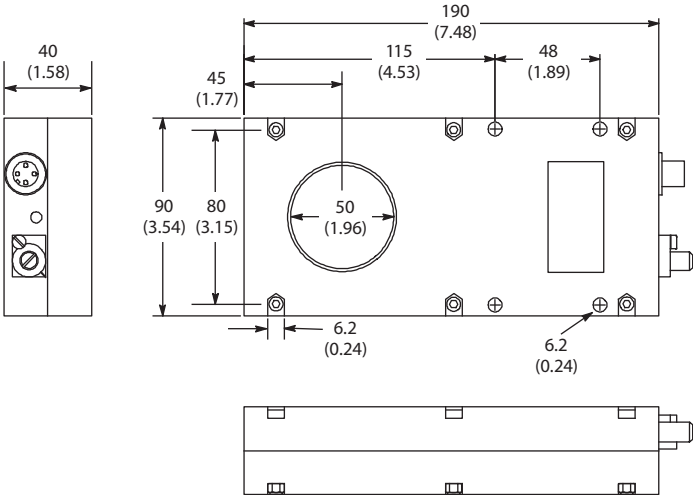

Complementary Normally Open and Normally Closed

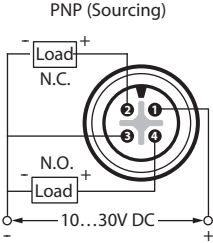

Micro Quick-Disconnect Style (871R-D100NP120-D4 & 871R-D100NN120-D4)

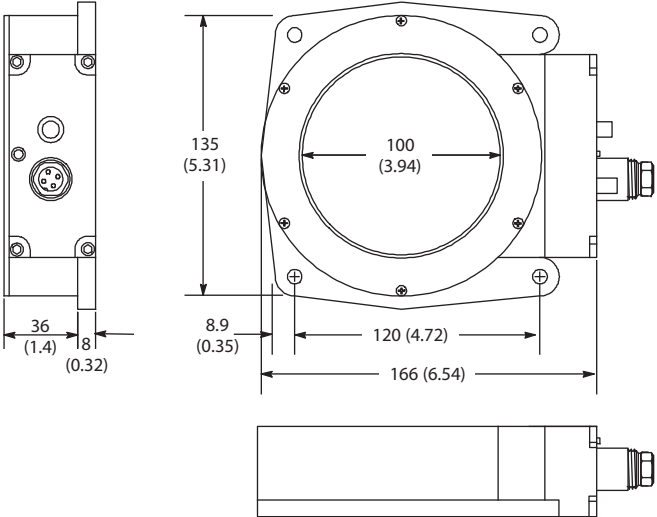

Complementary Normally Open and Normally Closed

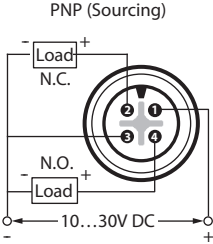

Ring & Slot Sensors

Bulletin 871S 3-Wire DC

Slot Style



871S DC Cable Style
30 mm Slot Gap

Specifications

Load Current	≤200 mA
Leakage Current	≤10 μA
Operating Voltage	18...30V DC
Voltage Drop	≤2.4V
Repeatability	≤2%
Hysteresis	15% typical
Protection Type	Transient noise & false pulse
Certifications	CE Marked for all applicable directives
Enclosure Type Rating	NEMA 4; IP65 (IEC 529)
Connection Type	Cable: 2 m (6.5 ft) length, 3-conductor #26 AWG PVC
Indicator LEDs	None
Operating Temperature [C (F)]	-25...+70 ° (-13...+158 °F)
Shock	5 g
Vibration	10...55 Hz

Approximate Dimensions [mm (in.)]

Cable Style

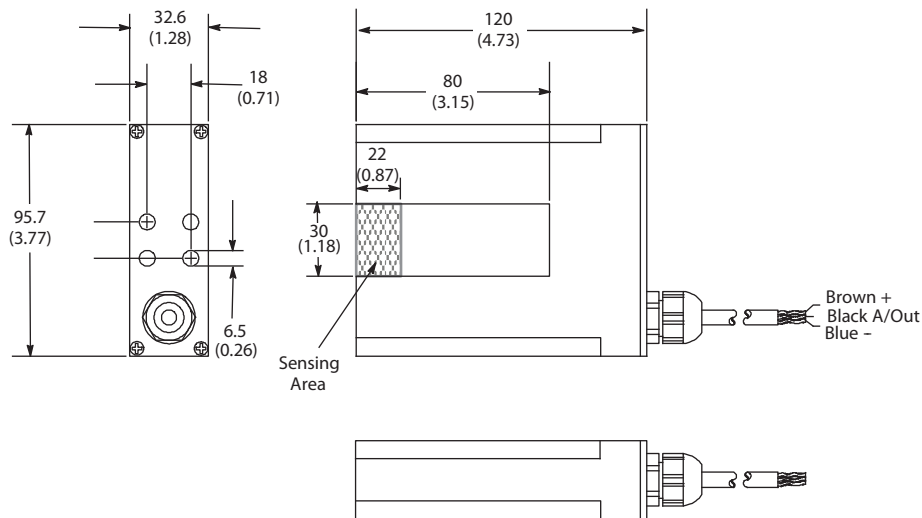

Wiring Diagrams

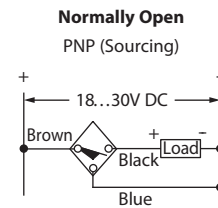

Rockwell Automation maintains current product environmental information on its website at <http://www.rockwellautomation.com/global/about-us/sustainability-ethics/product-environmental-compliance.page>

Allen-Bradley and Rockwell Automation are trademarks of Rockwell Automation, Inc. Trademarks not belonging to Rockwell Automation are property of their respective companies.

www.rockwellautomation.com

Power, Control and Information Solutions Headquarters

Americas: Rockwell Automation, 1201 South Second Street, Milwaukee, WI 53204-2496 USA, Tel: (1) 414.382.2000, Fax: (1) 414.382.4444
 Europe/Middle East/Africa: Rockwell Automation NV, Pegasus Park, De Kleetlaan 12a, 1831 Diegem, Belgium, Tel: (32) 2 663 0600, Fax: (32) 2 663 0640
 Asia Pacific: Rockwell Automation, Level 14, Core F, Cyberport 3, 100 Cyberport Road, Hong Kong, Tel: (852) 2887 4788, Fax: (852) 2508 1846

Publication PROX-TD001C-EN-P - December 2015
 Supersedes PROX-TD001B-EN-P - October 2015

Copyright © 2015 Rockwell Automation, Inc. All rights reserved. Printed in the U.S.A.