

U-GAGE™ Analog Q45U Long-Range Ultrasonic Sensors

*Piezoelectric Proximity Mode Sensors with Push-button
Programming of Sensing Window Limits*

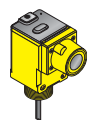

Features

- Ultrasonic proximity detection from 0.25 to 3.0 m (9.8" to 118")
- Push button TEACH-mode programming of sensing window limits
- Digital filtering for exceptional immunity to electrical and acoustic "noise"
- Selectable 0 to 10V dc voltage sourcing or 4 to 20mA current sourcing analog outputs
- Selectable output slope: positive or negative with increasing target distance
- Wide operating temperature range of -25° to +70°C; all models include temperature compensation
- Rugged design for use in demanding sensing environments; rated IEC IP67, NEMA 6P
- Choose models with integral 2 m (6.5') or 9 meter (30') cable, or with Mini-style or Euro-style quick-disconnect fitting
- Input for remote TEACH-mode programming of window limits

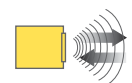

Ultrasonic

Analog Q45U Series Proximity Mode

Models	Temperature Compensation	Range	Cable*	Supply Voltage	Output Type	Response Time
Q45ULIU64BCR	Yes	250 mm - 3.0 m (9.8" - 118")	2 m (6.5')	15-24V dc	Selectable 0-10V dc or 4 - 20 mA sourcing	Adjustable from 80 milliseconds to 2.56 seconds
Q45ULIU64BCRQ			5-Pin Mini-style QD			
Q45ULIU64BCRQ6			5-Pin Euro-style QD			

* NOTES:

- 9 m (30') cables are available by adding suffix "W/30" to the model number of the cabled sensor (e.g., **Q45ULIU64BCR W/30**).
- A model with a QD connector requires an optional mating cable, see page 8.

Temperature Compensation:

All models listed above feature temperature compensation. An increase in air temperature shifts both sensing window limits closer to the sensor. Conversely, a decrease in air temperature shifts both limits further away from the sensor. The shift is approximately 3.5% of the limit distance for a 20°C change in temperature.

Temperature compensated models maintain the position of both sensing window limits to within 1% of each limit distance over the 0° to +50°C range, and to within 2.5% over the full operating range of from -25° to +70°C.

U-GAGE™ Analog Q45U Long-Range Ultrasonic Sensors

Near and Far Sensing Limit Settings:

The Q45U features a single push button for programming of sensing window near and far limits (Figure 1). See the programming procedure on page 4.

Status Indicators:

Status indicator LEDs are visible through the transparent, o-ring sealed acrylic top cover. Indicator function in the **RUN** mode is, as follows:

- The green LED is on steadily whenever power is applied to the sensor, and flashes to indicate a current output fault.
- The red LED lights when an echo is received, and flashes at a rate that is proportional to echo strength.
- The yellow LED lights whenever the target is within the operating window limits.

The 5-segment moving dot LED indicator displays the relative position of the target within the programmed sensing window. The #1 LED flashes when the target is closer than the near limit. The #5 LED flashes when the target is beyond the far limit.

Output Response Settings:

IMPORTANT: Remove power before making any internal adjustments.

Using the two slots shown in Figure 1, a small flat-blade screwdriver may be used to lift up and remove the black inner cover to expose the 4-position DIP switch (Figure 2).

Those switches are used to program the following functions: output slope, output mode, loss of echo, and min./max. output value default (see Figure 2).

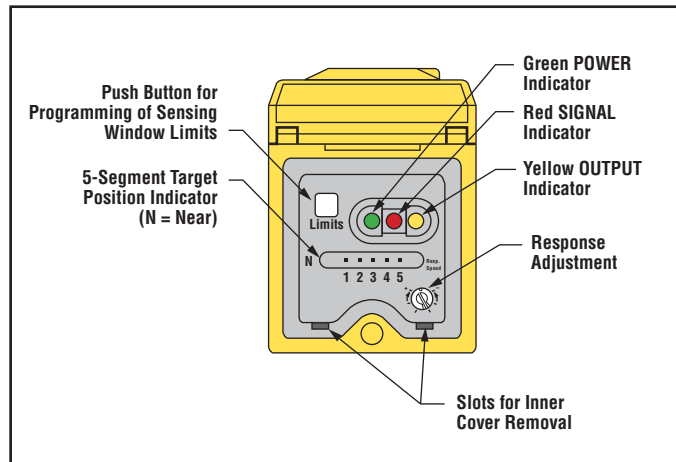

Figure 1. Analog Q45U Features

Switch	Function	Settings
1	Output Slope	On = Output value <i>increases</i> with distance Off* = Output value <i>decreases</i> with distance
2	Output Mode	On = Current output enabled Off* = Voltage output enabled
3	Loss of Echo	On = Min - Max Mode Off* = Hold Mode
4	Min - Max	On* = Default to maximum output value Off = Default to minimum output value

* Indicates factory settings

Figure 2. Analog Q45U Programming Switches

U-GAGE™ Analog Q45U Long-Range Ultrasonic Sensors

Explanation of Programmable Output Functions:

Switch 1: Output Slope Select

- On = Direct = Output value (voltage or current) increases with increasing distance of the target from the sensor
- Off* = Inverse = Output value decreases with increasing distance of the target from the sensor

Switch 2: Output Mode Select

- On = The 4 to 20 mA current output (white wire) is enabled
- Off* = The 0 to 10V dc voltage output (black wire) is enabled

This switch configures the D/A driver to use either the current output or the voltage output driver. **This output function can only be set with the power to the sensor turned off.**

Switch 3: Loss of Echo Mode Select

- On = Min - Max Mode
- Off* = Hold Mode

This switch determines the output response to the loss of echo. The “Hold Mode” (Switch 3 Off*) maintains the output at the value which was present at the time of echo loss. The “Min - Max Mode” (Switch 3 On) drives the output to either the minimum value (0V or 4mA or the maximum value (10V or 20mA) when the echo is lost. Minimum or maximum value is selected by Switch 4.

Switch 4: Min - Max Default

- On* = Default to maximum output value at loss of echo
- Off = Default to minimum output value at loss of echo

Switch 4 selects the output response to loss of echo when “Min - Max Mode” is selected by Switch 3 (see above).

Response Speed Adjustment

The speed of the output response is set using the single-turn potentiometer (see Figures 1 and 4). There are six values for response speed, which relate directly to the number of sensing cycles over which the output value is averaged. The response value is set by aligning the slot of the potentiometer with one of the marked positions. The positions are identified in Figure 4.

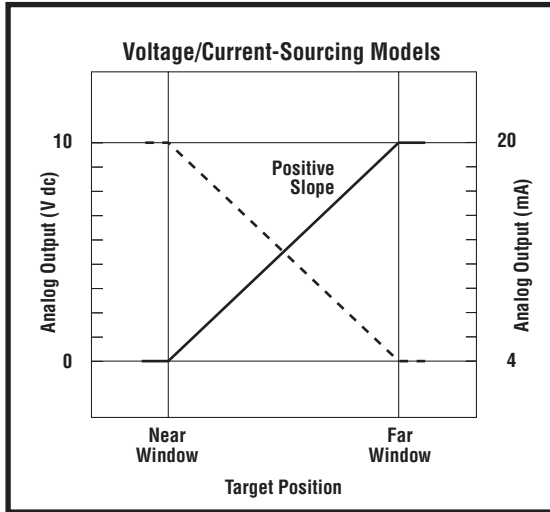

Figure 3. Output as a function of target position

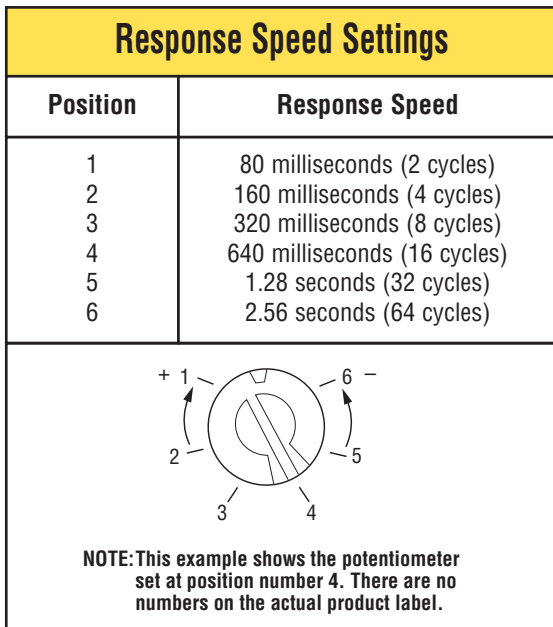

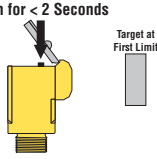
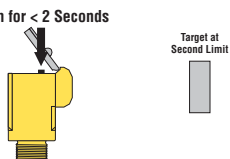

Figure 4. Response Adjustment Positions

U-GAGE™ Analog Q45U Long-Range Ultrasonic Sensors

Window Limit Programming

The “Limits” push button, located under the transparent top cover, is used to program the near and the far limits. The near limit may be set as close as 250 mm (9.8") and the far limit may be set as far as 3.0 m (118") from the transducer face. Minimum window width is 25 mm (1"). Whenever possible, use the actual target to be sensed when setting the window limits. The following procedure begins with the sensor in RUN mode.

Push Button	Indicator Status
<p>Step 1</p> <p>ACCESS LIMIT PROGRAMMING MODE</p> <p>Push and hold until green indicator turns off (approximately 2 seconds)</p>	<p>Push and Hold for ≥ 2 Seconds</p>  <p>Green: Goes off Yellow: Is on steadily to indicate ready for teaching first limit Red: Flashes to indicate strength of echo or is off if no target is present</p>
<p>Step 2</p> <p>SET FIRST LIMIT (Near or Far)</p> <p>Place the target at the first limit and press the push button for less than 2 seconds</p>	<p>Push for < 2 Seconds</p>  <p>Green: Remains off Yellow: Flashes at 2 Hz to indicate ready for teaching second limit Red: Comes on steadily for a moment, then resumes flashing to indicate strength of echo</p>
<p>Step 3</p> <p>SET SECOND LIMIT (Far or Near)</p> <p>Place the target at the second limit and press the push button for less than 2 seconds</p>	<p>Push for < 2 Seconds</p>  <p>Green: Remains off, then comes on steadily (returns to RUN mode) Yellow: On steadily for a moment, then is either on or off to indicate output state (returns to RUN mode) Red: Comes on steadily for a moment, then resumes flashing to indicate strength of echo (returns to RUN mode)</p>

Notes regarding window limit programming:

- 1) Either the near or far limit may be programmed, first.
- 2) There is a 2-minute time-out for programming of the first limit. The sensor will return to RUN mode with the previously programmed limits. There is no time-out between programming of the first and second limit.
- 3) The programming sequence may be cancelled at any time by pressing and holding the push button for ≥ 2 seconds. The sensor returns to RUN mode with the previously programmed limits.
- 4) During limit programming, the 5-segment moving dot indicator displays the relative target position between 0 and 4.0 meters (the maximum recommended far limit position is 3.0 meters).
- 5) If the target is positioned between 3.0 and 4.0 meters, the 5th segment of the moving dot indicator flashes to indicate that a valid echo is received, but the target is beyond the recommended 3.0 meter maximum far limit.
- 6) If a limit is rejected during either programming step, the sensor will revert to the first limit programming step (Step 2 in programming chart). This will be indicated by Green - off, Red - flashing to indicate signal strength, and Yellow - on steady.
- 7) If both limits are accepted, the sensor will return to RUN mode, which is indicated by the Green LED coming on steady.
- 8) If the target is held at the same position for programming of both limits, the sensor will establish a 50 mm-wide sensing window, centered on the target position.

U-GAGE™ Analog Q45U Long-Range Ultrasonic Sensors

Analog Q45U Series Specifications

Proximity Mode Range	Near limit: 250 mm (9.8") min Far limit: 3.0 m (118") NOTE: The far limit may be extended as far as 3.9 m for good acoustical targets (hard surfaces with area > 100 cm ²)
Supply Voltage and Current	15 to 24V dc (10% maximum ripple) at 100mA, exclusive of load
Supply Protection Circuitry	Protected against reverse polarity and transient voltages
Output Configuration	One voltage sourcing and one current sourcing; one or the other output is enabled by internal programming switch #2. Output function may be programmed by a 4-position DIP switch located on top of the sensor, beneath the transparent o-ring sealed acrylic cover (see page 3 for complete information)
Output Rating	Voltage sourcing: 0 to 10V dc, 10mA maximum Current sourcing: 4 to 20mA, 1 to 500 ohm impedance
Output Protection Circuitry	Both outputs are protected against continuous overload and short circuit
Performance Specifications	Sensing Repeatability: ±0.1% of the measured distance (±0.50 mm minimum) Sensing Resolution: 0.50 mm (0.02 in) Analog Output Resolutions: 2mV, 3µA
Indicators	Three status LEDs: Green ON steady = power to sensor is ON Green flashing = current output fault detected (indicates that the 4-20mA current path to ground has been opened) Yellow ON steady = target is sensed within the window limits (Yellow LED also indicates programming status during setup mode) Red flashing = indicates relative strength of received echo 5-segment moving dot LED indicates the position of the target within the sensing window
Construction	Molded PBT thermoplastic polyester housing, o-ring sealed transparent acrylic top cover, and stainless steel hardware. Q45U sensors are designed to withstand 1200 psi washdown. The base of cabled models has a 1/2"-14NPS internal conduit thread
Environmental Rating	Leakproof design is rated IEC IP67; NEMA 6P
Connections	2 m (6.5') or 9 m (30') attached cable, or 5-pin Mini-style or 5-pin Euro-style quick-disconnect fitting
Operating Temperature	Temperature: -25° to +70°C (-13° to +158°F) Maximum relative humidity: 100%
Vibration and Mechanical Shock	All models meet Mil. Std. 202F requirements. Method 201A (Vibration: 10 to 60Hz max., double amplitude 0.06-inch, maximum acceleration 10G). Method 213B conditions H & I (Shock: 75G with unit operating; 100G for non-operation) Also meets IEC 947-5-2 requirements: 30G, 11 ms duration, half sine wave
Application Notes	Minimum target size: 50 mm x 50 mm aluminum plate at 3.0 m (118")

U-GAGE™ Analog Q45U Long-Range Ultrasonic Sensors

Remote Window Limit Programming

The yellow wire of the Analog Q45U may be connected to a switch or process controller for remote programming of the sensing window limits. The programming procedure is the same as for the push button (see page 4).

A remote programming input is generated when +5 to 24V dc is applied to the yellow wire. The timing diagrams, below, define the required input pulses.

Notes regarding remote window limit programming:

- 1) The push button is disabled during remote limit programming. (The remote programming input is disabled during push button programming.)
- 2) Also see the notes regarding window limit programming on page 4.

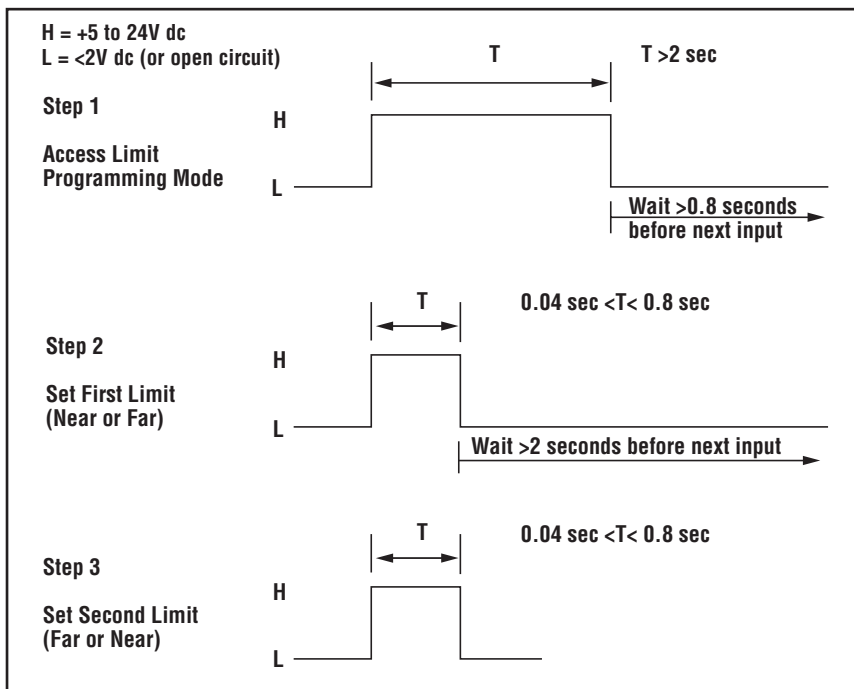
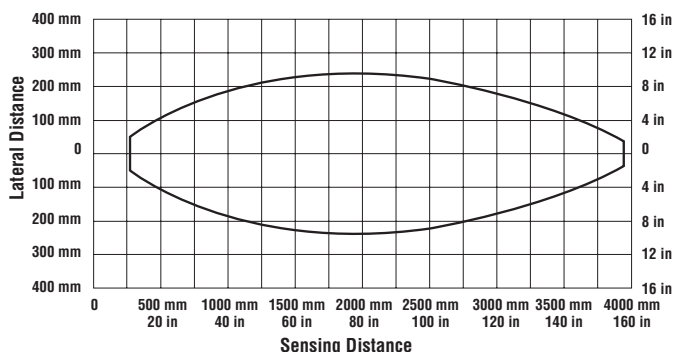

Figure 5. Remote window limit programming

Analog Q45U Response Curves

Analog Q45U Effective Beam with 100 mm x 100 mm Plate Target (Typical)



Analog Q45U Effective Beam with 2.5 cm Dia. Rod Target (Typical)

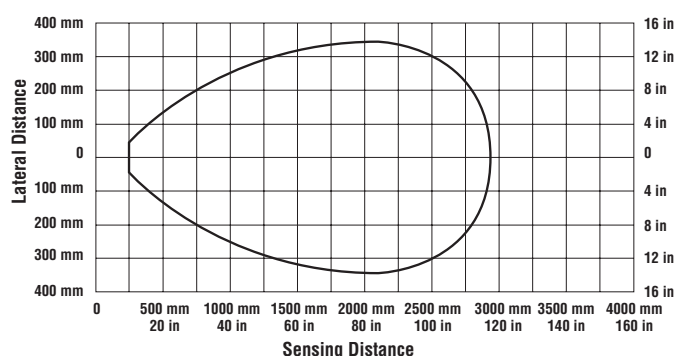

U-GAGE™ Analog Q45U Long-Range Ultrasonic Sensors

Analog Q45U Series Hookups

Q45U Sensor with Attached Cable

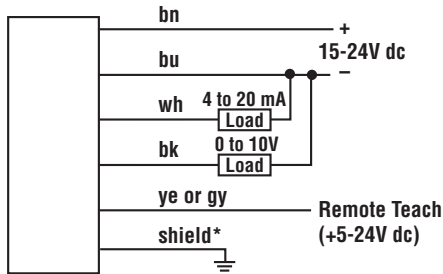

Q45U Sensor with 5-Pin Mini-Style QD ("Q" model suffix)

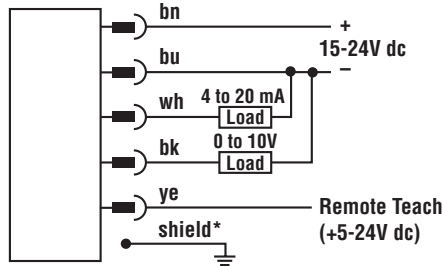

Q45U Sensor with 5-Pin Euro-Style QD ("Q6" model suffix)

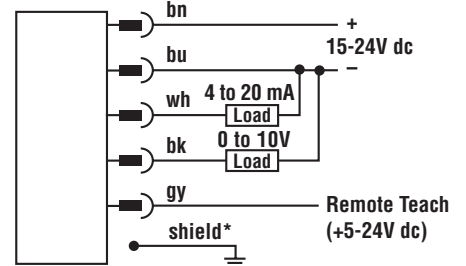

*It is recommended that the shield wire be connected to earth ground or dc common.

5-Pin Mini-Style Pin-out (Cable Connector Shown)

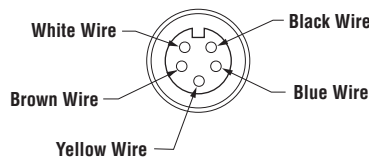

5-Pin Euro-Style Pin-out (Cable Connector Shown)

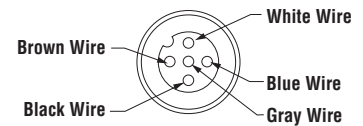

Analog Q45U Series Dimensions

Q45U Sensor with Attached Cable

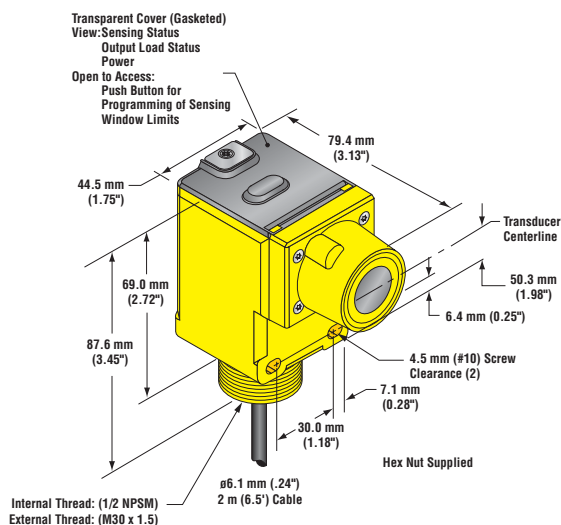

Q45U Sensor with 5-Pin Mini-Style QD ("Q" model suffix)

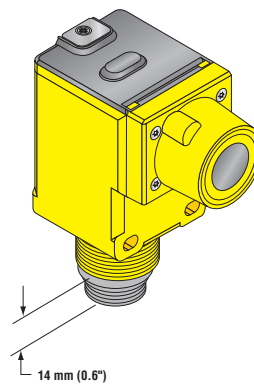

Q45U Sensor with 5-Pin Euro-Style QD ("Q6" model suffix)

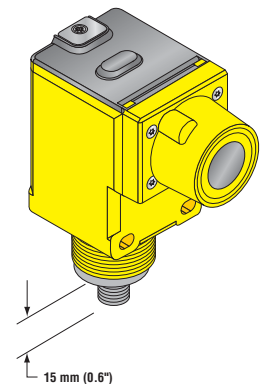

U-GAGE™ Analog Q45U Long-Range Ultrasonic Sensors

Quick-Disconnect (QD) Cables

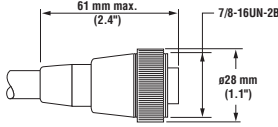
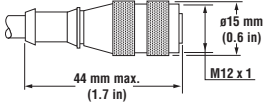
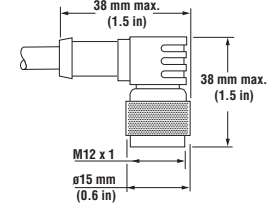
Description	Model	Length	Connector
5-Pin Mini-style with shield	MBCC2-506 MBCC2-512 MBCC2-530	2 meters (6.5') 4 meters (12') 9 meters (30')	
5-Pin Euro-style Straight with shield	MQDEC2-506 MQDEC2-515 MQDEC2-530	2 meters (6.5') 5 meters (15') 9 meters (30')	
5-Pin Euro-style Right-angle with shield	MQDEC2-506RA MQDEC2-515RA MQDEC2-530RA	2 meters (6.5') 5 meters (15') 9 meters (30')	

WARRANTY: Banner Engineering Corp. warrants its products to be free from defects for one year. Banner Engineering Corp. will repair or replace, free of charge, any product of its manufacture found to be defective at the time it is returned to the factory during the warranty period. This warranty does not cover damage or liability for the improper application of Banner products. This warranty is in lieu of any other warranty either expressed or implied.



WARNING . . .
Not to be used for personnel protection

Never use these products as sensing devices for personnel protection. Doing so could lead to serious injury or death.

These sensors do NOT include the self-checking redundant circuitry necessary to allow their use in personnel safety applications. A sensor failure or malfunction can cause either an energized or de-energized sensor output condition. Consult your current Banner Safety Products catalog for safety products which meet OSHA, ANSI, and IEC standards for personnel protection.

Mounting Brackets

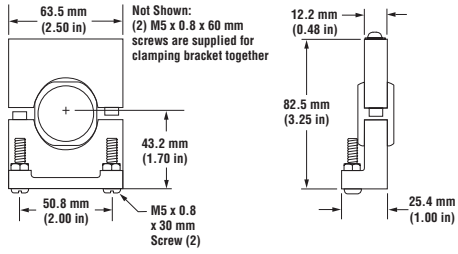
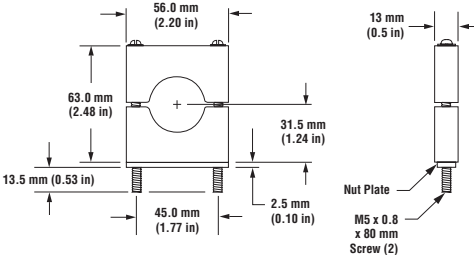
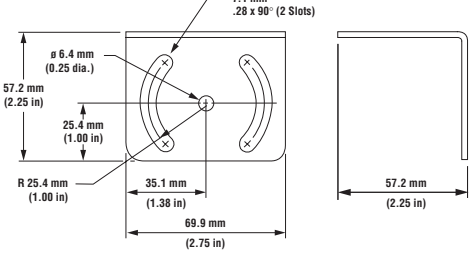
Model	Description	Dimensions
SMB30S	<ul style="list-style-type: none"> 30 mm swivel, black PBT bracket Stainless steel mounting hardware included 	 <p>Not Shown: (2) M5 x 0.8 x 60 mm screws are supplied for clamping bracket together</p>
SMB30C	<ul style="list-style-type: none"> 30 mm split clamp, black PBT bracket Stainless steel mounting hardware included 	
SMB30MM	<ul style="list-style-type: none"> 30 mm, 11-gauge, stainless steel bracket with curved mounting slots for versatility and orientation Clearance for M6 (1/4") hardware 	

BANNER®
more sensors, more solutions