

CANDELABRA LAMP HOLDERS

Plastic • Klik-Snap™

E12 Base



INCANDESCENT

Fast-Installation Klik-Snap Candelabra Lampholders for Lanced Panels

Snap-in design permits easy assembly of lampholders to fixture. Eliminates cost of riveting bracket to panel. Standard leads are #18 ga. 105°C AWM-TEW plastic insulated wire, 4 1/2" long, stripped 1/2". Other wire specifications available.

Both types of externally threaded sockets available in harness sets of two or more sockets (minimum center-to-center distance is 2").

Cat. No. 10032-010: Plastic body.

Cat. No. 10032-210: Plastic body with flange.

- UL Listed E-13400 • CSA Certified LR-1863

NOTE: With #18-2 SPT-1, maximum number of sockets per application is 16; with #18 ga. 105°C AWM-TEW plastic insulated wire, maximum number of sockets per application is 10.



10032-210



X-25297

Finishing Nuts

Order Separately

Cat. No. X-25297: Flat Brass (Also available with nickel finish.)

Cat. No. X-25298: Shouldered Brass (Also available with nickel finish.)

Cat. No. BA-23569: Brown Molded Plastic



BA-23569

DIMENSIONS

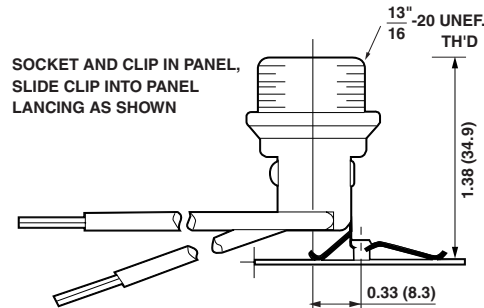
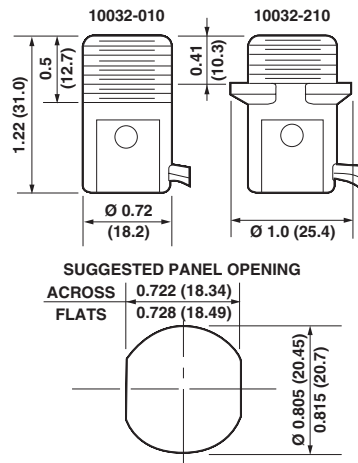

Cat. No. 10032-210

FLAT BRASS

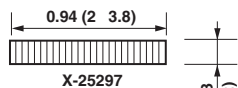

SHOULDERED BRASS

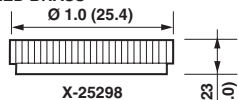

BROWN MOLDED PLASTIC

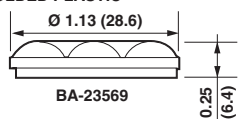

ORDER FINISHING NUTS SEPARATELY

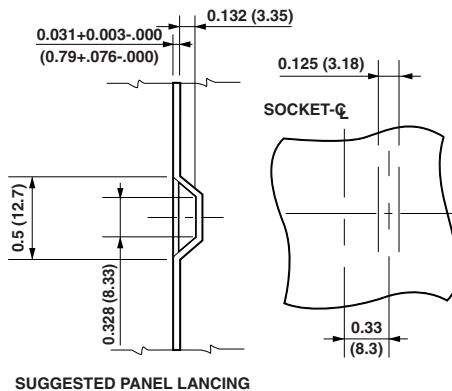

SUGGESTED PANEL LANCING