

EFH Flexible Cushion Luminaire Hangers

For Pendant Mount

Cl. I, Div. 1 and 2, Groups C, D
 Cl. II, Div. 1, Groups E, F, G
 Cl. II, Div. 2, Groups F, G
 Cl. III

Explosionproof
 Dust-Ignitionproof

7L

Applications:

EFH Flexible Cushion Luminaire Hangers are used in hazardous locations:

- Where a luminaire must hang more than 12" from its supporting junction box (as required by NEC Article 501 and CEC Part I Section 18)
- To assure that luminaires hang plumb and will swing freely if accidentally struck; prevents damage to luminaire, stem, and supporting outlet box
- To provide a cushion support, prolonging lamp life and protecting the luminaire from shock and vibration; for luminaires weighing up to 65 lbs.

Features:

- Complies with NEC Article 501 and CEC Part I Section 18
- Free swinging in any direction through an angle of 15 degrees from perpendicular
- Weight of luminaire is supported by a high strength brass bellows and a stainless steel cushioning spring
- Two part assembly consisting of luminaire hanger cover and CPS12 outlet box; provides a wide variety of conduit arrangements; a set-screw locks the conduit stem in place

Certifications and Compliances:

- NEC/CEC:
 - Class I, Groups C, D
 - Class II, Groups E, F, G
 - Class III
- UL Standard: 1203
- CSA Standard: C22.2 No. 30

Standard Materials:

- *Feraloy*[®] iron alloy

Standard Finishes:

- Electrogalvanized and aluminum acrylic paint

Size Ranges:

- Conduit hubs – 3/4" with 3/4" to 1/2" reducers
- Luminaire stem – 1/2" and 3/4"
- Luminaire weight – 65 lbs. max.

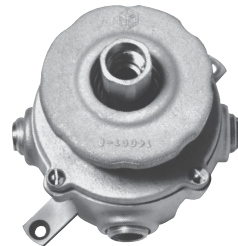

EFHX

Body Hub Size*	Luminaire Stem Size	With Mtg. Feet Cat. #
1/2 and 3/4	1/2	EFHX111
1/2 and 3/4	3/4	EFHX221

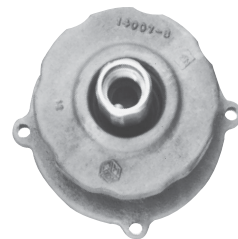

Cushion Luminaire Hanger Only

Stem Size	Cat. #
1/2	EFH01
3/4	EFH02

Dimensions In Inches:

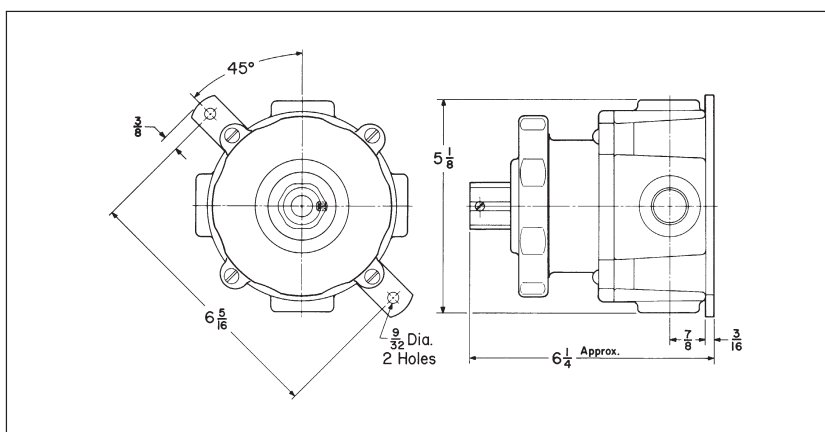

*Furnished with four 3/4" standard taper tapped, integrally bushed hubs. Each hub as a 3/4" to 1/2" reducer. Three hubs are plugged.

