

# FVS Series Long Twin Tube

## Fluorescent Luminaires

Cl. I, Div. 2, Groups B, C, D  
Cl. II, Div. 1, Groups E, F, G  
Cl. II, Div. 2, Groups F, G  
Cl. III, Simultaneous Presence

Marine & Wet Locations  
3, 3R, 4, 4X; IP66

**5L**

### Applications:

FVS Compact Fluorescent Luminaires are used:

- Where low mounting heights or limited mounting room exists
- For task oriented lighting
- Where a cool, efficient light source is required
- In areas that require lamps to reach full illumination immediately
- In industrial and chemical processing
- In pulp and paper facilities
- In waste or sewage treatment facilities
- In non-hazardous commercial and industrial areas
- In food and pharmaceutical plants where a non-glass lens is required
- Where fluorescent lighting has been preferred, but unavailable due to limited space and practicality

### Features:

- Compact, lightweight, low profile design is ideal for confined areas and tight corners
- Reaches full illumination immediately and delivers light output equivalent to fixtures twice its size
- Fast-Latch™ closure provides quick and easy access for relamping and maintenance – no tools necessary
- Silicone sealing gasket provides exceptional watertight and dust-tight bond, providing excellent performance in wet and corrosive environments
- Power disconnect switch (Eaton's Crouse-Hinds ESWP) automatically cuts power to the lamps and ballast when the lens is opened
- Shatter-resistant polymeric lens (0.125 thick) provides environmental and corrosion protection
- Available in UNV (120-277) and 347 50/60 Hz voltages
- Two lamp fixture, uses single-ended 40 watt lamps
- Multiple mounting capability
- Energy saving electronic ballast is standard

### Standard Materials:

- Corrosion-resistant die cast copper-free aluminum housing
- Shatter-resistant nylon lens
- Polycarbonate lens (suffix -S813)
- Silicone rubber gasket
- Extruded aluminum hinges and closure hardware with stainless steel pivots

### Standard Finishes:

- Epoxy powder coated housing
- Anodized hinges and closure hardware
- Highly specular aluminum reflector

**Crouse-Hinds**  
by **E.T.N**



### Certifications and Compliances:

- NEC and CEC:
  - Class I, Division 2, Groups B, C, D
  - Class II, Division 1, Groups E, F, G (Suffix S813)
  - Class II, Division 2, Groups F, G
  - Class III & Simultaneous Presence (Cl. I and Cl. II)

#### Note: Aiming Limitations

- Cl. II, Cl. III & Simultaneous Presence
  - Aim down to Horizontal
  - Cannot aim up
- UL Standards
  - 844 Hazardous (Classified) Locations
  - 1598 Luminaires
  - 1598A Marine Locations
- CSA Standards
  - C22.2 No. 137

### Options:

#### Description

- Fused to protect ballast under abnormal line conditions (not available on CSA certified fixtures) (not suitable for marine applications) ..... **S658**
- Fixture supplied with two F40BX/SPX35 lamps ..... **S714**
- Corro-free™ epoxy finish inside and out ..... **S753**
- Tamperproof ..... **Consult Eaton's Crouse-Hinds**

### Temperature Performance Data:

Style	Ambient Temp °C	Class I, Div. 2	Class II See Aiming	Simultaneous Presence Limitations	Supply Wire	Minimum Operating Temperature
All	40°C	T3C	T6	T3C/T6	75°C	-18°C (0°F)
All	55°C	T3C	—	—	75°C	-18°C (0°F)

### Luminaire Weight: Without Lamps

Type	lbs.
Standard 2 lamp FVS	12.0

### Size Ranges:

- All luminaires are 24" L x 12" W x 3.12" H
- Conduit entrances are 3/4"

### Electrical Ratings:

- UNV (120–277V), 50–60 Hz
- 347V, 60 Hz
- Two 40 watt long twin tube lamps

### Accessories

FVS Trunnion Mount Kit (FVS-K5)

- Permits vertical mounting of luminaire on a beam when used with a standard beam clamp
- Can be mounted directly to a wall or ceiling
- Can be pole mounted when used in conjunction with a SFA6 slipfitter adapter (ordered separately)
- Constructed from copper-free aluminum
- Supplied with a CGB cord connector

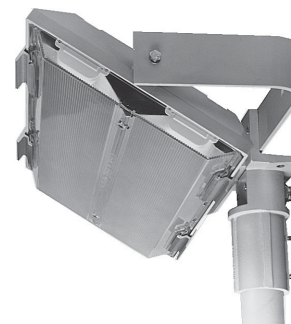

FVS with Trunnion Arm and Slipfitter

**5L**

5L

# FVS Series Long Twin Tube

Fluorescent Luminaires

Cl. I, Div. 2, Groups B, C, D  
Cl. II, Div. 1, Groups E, F, G  
Cl. II, Div. 2, Groups F, G  
Cl. III, Simultaneous Presence

Marine & Wet Locations  
3, 3R, 4, 4X; IP66

Luminaire includes all necessary provisions for these installations:



Ceiling Mount



Pendant Mount

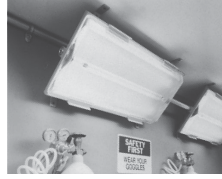

Corner Mount



Horizontal Wall Mount



Vertical Wall Mount

## FVS compact fluorescent (2 lamp luminaire):

Voltage	Wattage/ Lamp	Hub Size (4)	Cat. #	Cat. # with Class II, Div. 1 Suitability
120-277 (50 or 60 Hz)	40	3/4"	FVS20/UNV	FVS20/UNV S813
347 (50 or 60 Hz)	40	3/4"	FVS23	FVS23 S813

## Accessories (Ordered Separately):

Description	Cat. #
• Trunnion arm kit	FVS K5
• Slipfitter adapter to be used with trunnion arm	SFA6

## Dimensions:

FVS with Trunnion Arm: 26 1/4" x 13.5" W x 3.12" H

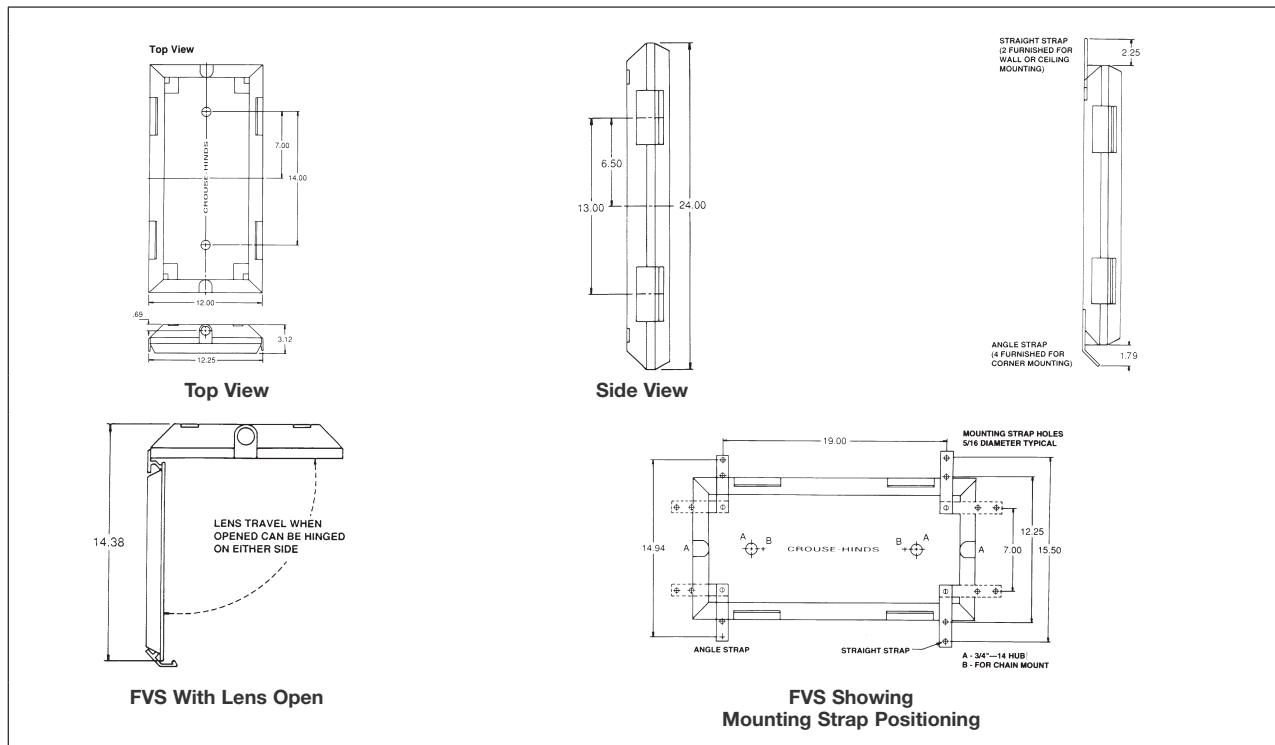

5L

# FVS Series Long Twin Tube

Photometric Data

5L

## Fluorescent Luminaires

### Luminaire: FVS

Lamp: (2) F40BX/SPX35/RS single-ended fluorescent.  
Total initial lumens: 6300

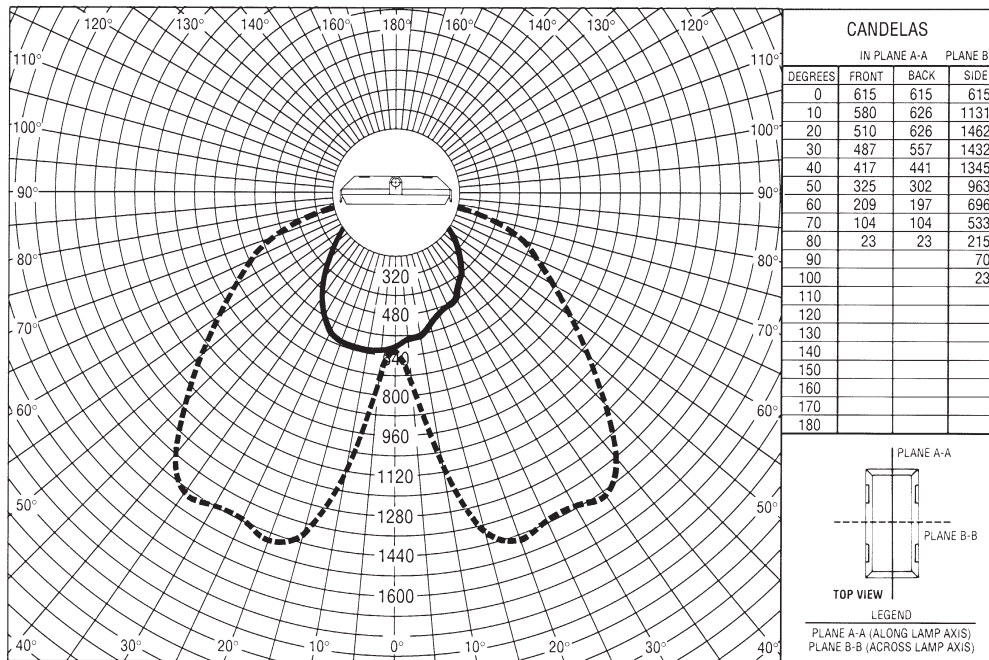

### Isofootcandle Chart

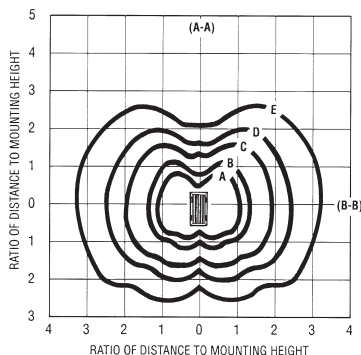

### Footcandle Values for Isofootcandle Lines

Mtg. Hgt.	A	B	C	D	E
8'	5.00	3.00	1.00	0.50	0.20
10'	3.20	1.92	0.64	0.32	0.13
12'	2.22	1.33	0.44	0.22	0.09
16'	1.25	0.75	0.25	0.13	0.05

### Spacing to Mounting Height Ratio

Along lamp axis (A-A)	0.6
Across lamp axis (B-B)	1.1

### Coefficients of Utilization

Effective Floor Cavity Reflectance 20%

Eff. Ceil.	Wall	Room Cavity Ratio									
		1	2	3	4	5	6	7	8	9	10
80*	50*	.621	.538	.469	.414	.367	.329	.297	.269	.246	.225
	30*	.594	.495	.419	.359	.312	.273	.242	.216	.195	.176
	10*	.569	.459	.378	.317	.270	.234	.204	.180	.160	.144
70*	50*	.606	.526	.459	.405	.360	.323	.291	.265	.242	.222
	30*	.582	.487	.412	.354	.308	.270	.240	.214	.193	.175
	10*	.560	.453	.374	.314	.268	.232	.203	.179	.160	.143
50*	50*	.580	.503	.441	.389	.347	.311	.281	.256	.234	.216
	30*	.560	.470	.400	.345	.300	.265	.235	.210	.190	.172
	10*	.541	.442	.367	.310	.265	.230	.201	.178	.159	.143
30*	50*	.555	.483	.423	.374	.334	.301	.272	.248	.227	.210
	30*	.539	.455	.389	.336	.293	.259	.230	.207	.187	.170
	10*	.524	.431	.360	.305	.262	.227	.199	.176	.157	.142
10*	50*	.533	.464	.407	.361	.322	.290	.264	.241	.221	.204
	30*	.520	.441	.378	.327	.287	.254	.226	.203	.184	.167
	10*	.507	.421	.353	.300	.258	.225	.197	.175	.156	.141
0*	0*	.494	.407	.339	.286	.245	.212	.185	.163	.145	.130

\*Percent Reflectance.

†FVS suitable for Class II, Div. 1, Groups E, F, G when ordered with suffix S813.

## Crouse-Hinds

by E.T.N