

Pro

ProStep 814/816/ml



FEATURES

- Low profile flush mount step light.
- 814 models include louver to reduce glare and direct light.
- High temperature silicone gasket provides a watertight seal.

APPLICATIONS

- Marine and watertight requirements
- Gangway/walkway steps

APPROVALS

- Conforms to IP66
- Marine Outside Type Saltwater
- ABS

STANDARDS

- UL 1598A - Luminaires for Marine Vessels

TECHNICAL SPECIFICATIONS

HOUSING AND LENS FRAME

Cast copper free aluminum.

COVERS

Cast copper free aluminum with an electrostatically applied light gray polyester powder coat finish.

HARDWARE

Stainless steel.

ENTRIES

Standard units undrilled. Up to 1" NPT four way available. See ENTRY OPTIONS for selections.

GASKET

One piece silicone.

MOUNTING

Recessed wall type. See DIMENSIONS for details.

LAMP HOLDER

Medium base, porcelain.

LENS

Tempered glass.

LAMP TYPE

A-19 40w incandescent. Lamp not provided.

VOLTAGE

Rated to 250v.

ORDERING REFERENCES

PART NUMBER	DESCRIPTION	NO. LAMPS	WEIGHT LBS
814AS	Clear Lens, Surface Louver	2	3.8
816AS	Frosted Lens, No Louver	2	3.6

SPARE PARTS

Part No.	Description
INX4088	LAMP HOLDER
INX2114	LENS, 814, Clear
INX2002	LENS, 816, Frosted
INX3531	LAMP, 40w A-19
GKT5024	GASKET, Lens Frame
GKT5089	GASKET, Mounting

ENTRY OPTIONS

NPT Trade Size	Dead End*	Thru Feed*	X-Positions
1/2"	E1	C1	X1
3/4"	E2	C2	X2
1"	E3	C3	X3

*Entries on short side of casting.

DIMENSIONS

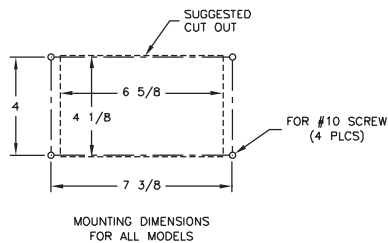
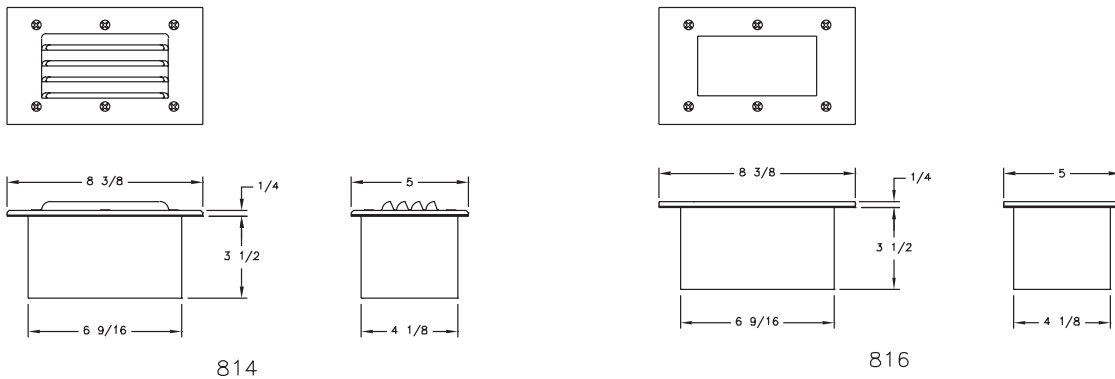

Dimensions in inches