

Intraground® N1 Series Non–Metallic Circuit Breakers and Enclosures

Explosionproof, Non-Factory Sealed

Class I, Division 1 and 2, Groups C, D
NEMA 3R, 4X, 7CD ♦, 12

Applications

- Short circuit protection and safe disconnect means.
- Thermal time delay overload protection for branch circuits for lighting, appliance and motor circuits.
- Ideal for use in corrosive atmospheres.
- Designed for use in locations made hazardous by the presence of flammable gases or vapors, such as those encountered in
 - Refineries
 - Chemical plants
 - Petrochemical plants
 - Other processing plants

Features:

- 15, 20, and 30 Amp single pole circuit breakers for 120 Vac operation.
- Dead-end or feed-thru hubs: 1/2" or 3/4".
- Furnished with lead wires for ease of connection.
- Breaker mounted on cover.
- Handle may be locked in ON or OFF position.
- External mounting lugs for ease of installation.
- Smooth, rounded integral bushing in each hub protects conductor insulation.
- Non-metallic construction with metal imbedded grounding grid. No need to install special wires and parts for grounding.
- Corrosion-resistant, strong, stainless steel Teflon® coated hex-head cap screws attach cover and body for approved flame-tight construction.
- Operating handle has close-tolerance threaded stainless steel shaft to meet explosionproof requirements.
- Unique labyrinth-path construction assures flame-tight joint between body and cover.
- Silicone gasket, specially designed for the labyrinth-path joint, prevents entrance of moisture without interfering with the venting of cooled hazardous gases and vapors.
- High strength thermoplastic polyetherimide, together with thick wall (5/16") and sound structural design (rounded corners) provides superior resistance to impact and crushing.
- Excellent resistance to ultraviolet light and water.
- Excellent conduit connection strength.
- Excellent resistance to attack by fungi and mold.
- Excellent heat deflection temperature.
- Superior flammability resistance.
- Furnished with a 3/4" to 1/2" NPT reducer.

Standard Materials

- Body and cover: 30% glass-reinforced thermoplastic polyetherimide in a neutral color
- Handle: nylon 6/6
- Cover bolts: stainless steel
- Nameplates: aluminum

Standard Finishes

- Cover bolts: Teflon®
- Nameplates: Mylar®



Certifications and Compliances

- UL Standard: UL 1203
- UL Listed: E59122

Related Products

- For classified location push button, pilot light and selector switch control stations, see *Controls Section*.
- Sealing fittings not furnished, see *Fittings Section*.

♦ For Class I, Division 1 applications sealing fittings must be field installed adjacent to enclosure on all conduit runs.

Intraground® N1 Series Non-Metallic Circuit Breakers and Enclosures

Explosionproof, Non-Factory Sealed

Class I, Division 1 and 2, Groups C, D
NEMA 3R, 4X, 7CD ♦, 12

Enclosures with Square D Type "QOU" Single Pole Breakers for 120/240 Vac Operation

	Amp	Hub Size (Inches)	Catalog Number	
			Dead-End	Feed-Thru
	15 Amp	1/2 or 3/4	N1D7515B	N1DC7515B
	20 Amp	1/2 or 3/4	N1D7520B	N1DC7520B
	30 Amp	1/2 or 3/4	N1D7530B	N1DC7530B

Dimensions

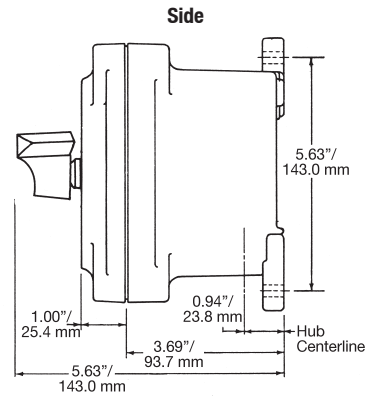
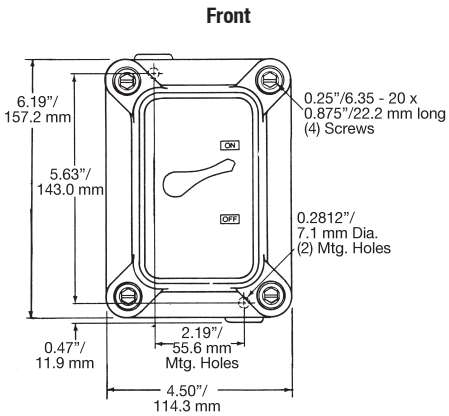

Distribution Equipment

DISTRIBUTION EQUIPMENT: HAZARDOUS LOCATION CIRCUIT BREAKERS

♦ For Class I, Division 1 applications sealing fittings must be field installed adjacent to enclosure on all conduit runs.