

Blend precision & performance in a downlight.

C4LA CALCULITE LED 4" ADJUSTABLE ACCENT

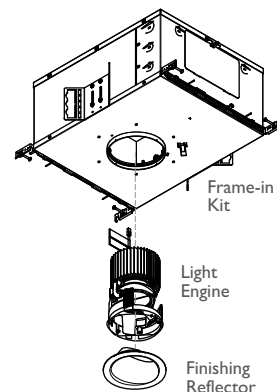

Complete product =
Frame-in Kit + Light Engine + Finishing Reflector

Project: _____
 Location: _____
 Catalog No: _____
 Fixture Type: _____
 Mfg: _____ Lamps: _____ Qty: _____
 Notes: _____

PHILIPS LIGHTOLIER, CALCULITE, PROFESSIONAL-GRADE
 DOWNLIGHTING, LED 4" ADJUSTABLE ACCENT, 1500LM,
 C4LA

Calculite LED 4" features an LED array of high brightness white light LEDs.
 Preliminary Specification Sheet.

Frame-in Kit

example: C4LA15NUZ10VAIC

Series	Style	Lumens	Installation	Voltage	Dimming
C4L	A	15	N	U	<input type="checkbox"/>
C4L Calculite 4" LED	A Adjustable Accent	15 1500lm	N New construction	U Universal 120V/277V	Z10V Non-IC with 0-10V dimming Z10VAIC AirSeal-IC with 0-10V dimming LD Non-IC with Lutron dimming LDAIC AirSeal-IC with Lutron dimming

Light Engine

example: C4L15A30K8SP

Series	Lumens	Style	CCT	CRI	Optics
C4L	15	A	<input type="checkbox"/>	<input type="checkbox"/>	<input type="checkbox"/>
C4L Calculite 4" LED	15 1500lm	A Adjustable Accent	27K 2700K 30K 3000K 35K 3500K ¹ 40K 4000K ¹	8 80 CRI 9 90 CRI ¹	TSP 11° Tight Spot SP 17° Spot NF 22° Narrow Flood FL 29° Flood

Finishing Reflector

example: C4LACLW

Series	Style	Finish	Flange
C4L	A	<input type="checkbox"/>	<input type="checkbox"/>
C4L Calculite 4" LED	A Adjustable Accent	CL Clear CCL Comfort Clear CCD Comfort Clear Diffuse CCZ Champagne Bronze WH White (painted)	W White (painted) P Polished (matches aperture) FT Flangeless (flush-mount) ²

1. Configurations using 90 CRI (9) are not compatible with 3500K (35K) and 4000K (40K) CCTs.
 2. Accessory CA4FMR required for gypsum applications (minimal 1/4" reflector flange).



PHILIPS
LIGHTOLIER

C4LA CALCULITE LED 4" ADJUSTABLE ACCENT

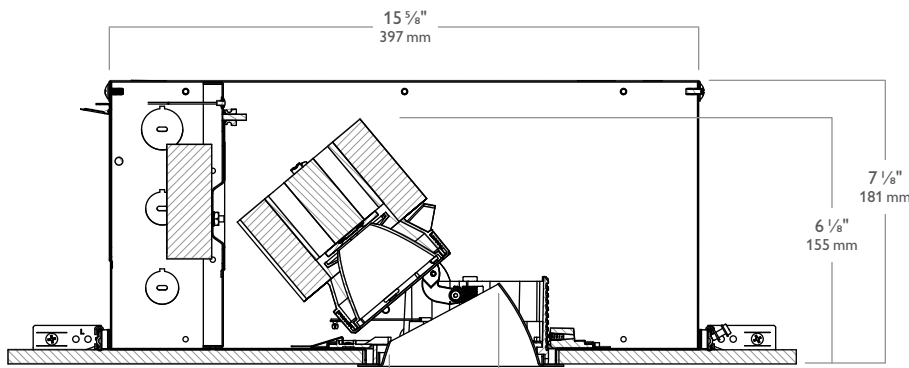

Complete product =
Frame-in Kit + Light Engine + Finishing Reflector

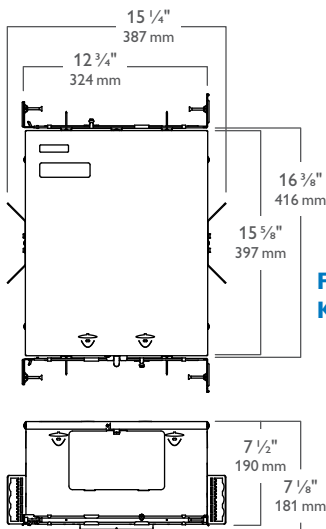

Frame-in Kit

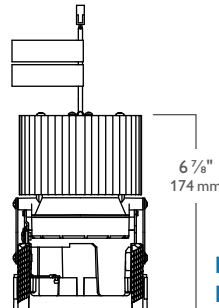

Light Engine

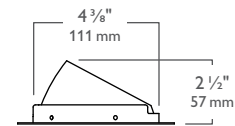

Finishing Reflector

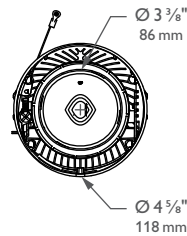

Features

- Finishing Reflector attachment:** Attaches to the Light Engine, which is keyed to ensure correct installation. Magnetic attachment helps to ensure Finishing Reflector is mounted flush with the ceiling and prevents gaps that can commonly occur with traditional friction spring installs. Allows for secure fit, but is much easier to remove/install when making adjustments.
- Steel cable tether:** Discrete tether fixed to the Light Engine body with snap in connector to Finishing Reflector body and holds securely while aiming unit or applying filters.
- Aperture Cone:** Low brightness; 0.050" aluminum, anodized; Self-flange in painted white or aperture matching polished flange. Flangeless option requires Mud-in Ring accessory.
- Light Engine retention:** mechanism is attached to Frame-in Kit by 3 symmetrically offset spring loaded ball and groove mating parts (patent pending).
- Light Engine vertical adjustment:**
 - Die-cast aluminum, 4 bar linkage design always maximizes accent light output at all angles through the 0°-40° vertical adjustment, while simultaneously minimizing glare within the cone.
 - EZ-Aim helical drive system provides fast and accurate hot aiming with phillips-head screwdriver. Vertical adjustment automatically locks once aiming is completed.
 - Unitized optics to ensure proper lamp orientation regardless of ceiling thickness.
 - Inherent aiming Indicator within Light Engine assembly (10° increments) to clearly identify respective angle of adjustment and allow for consistent aiming between fixtures if desired.
- Horizontal Adjustment Mechanism:** Die-cast aluminum ring with matte black finish. Unique design which allows for 366° horizontal rotation with positive stop and tool-less adjustment (patent pending).
- Light Engine Assembly:** LED light engine is particularly positioned to have 50° cut-off at nadir position for adjustable accent. LED Light engine traverses thru adjustment for ideal light source positioning and maximizing accent capability.
- Optics:**
 - 4 beam spread options available. Can be ordered separately as tool-less field replacements; Tight Spot 11°, Spot 17°, Narrow Flood 22°, and Flood 29°
 - 1 filter can be used. Up to 1/4" thick of standard 3 1/8" diameter accessories.
 - Custom engineered diffusion film (optional) helps smooth/diffuse/soften any beam spread.
- Thick Ceiling Ready Brackets:** Adj. Accent functions ideally tuned at 5/8" ceiling thicknesses, but is capable of being utilized in ceiling up to 2" thick with lessened adjustability.
- Frame Mounting:** Accommodates virtually any commercial installation with adjustable, pre-installed mounting brackets and user supplied 1/2" EMT Tubing or Philips Lightolier supplied mounting bars. Additionally accommodates mounting to residential joist (steel or wood) construction spacing from 12" to 24" On Center joists with supplied mounting bars (Lytning Bars). Minimum joist height of 8" required.
- LED Driver:** Serviceable and Replaceable from below ceiling. Two compatible dimming technologies are available depending on driver option: 0-10 Volt, and 27W Lutron Dimming (Non-IC and IC).

- Frame-In Kit:** See Frame-In Kit specification sheets for more information. For Non-IC, insulation must be kept 3" away from any parts of the luminaire and must not be placed above luminaire in a manner which will entrap heat. For IC AirSeal, luminaire may be in direct contact with thermal insulation.
- Lifetime:** 36,000 hours at L70.

Optical Reflectors

- CA4ATSP:** 11° Tight Spot
CA4ASP: 17° Spot
CA4ANF: 22° Narrow Flood
CA4AFL: 29° Flood

Options and Accessories

- CA4DF5:** 3 1/8" dia. diffusion filter for soft focus beam spreads
CA4FMRLED: 4 13/16" dia. Mud-in ring for flangeless installations

Frame-in Kits

- AirSeal:** Integral to IC rated Frame-in Kit.
Chicago Plenum: Integral to IC rated Frame-in Kit.

Labels

cU.L.us (Suitable For Damp Locations), I.B.E.W.

CCT Adjust. factors

102% = 4000K
 100% = 3500K
 96% = 3000K
 86% = 2700K

CRI Adjust. factors

100% = 80CRI
 82% = 90CRI

Example: Tight Spot, 2700K, 90CRI

Housing	Trim	Reflector
C4LA15NULD	C4L15A27K9TSP	C4LACLW
31,939 cd CBCP	x 86% @ 2700K CCT	x 82% @ 90 CRI = 23,309 cd CBCP

30° Horizontal Aiming

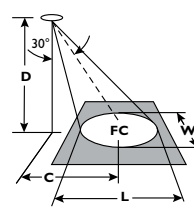

30° Vertical Aiming

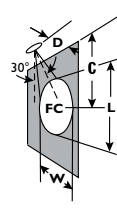

C4LA CALCULITE LED 4" ADJUSTABLE ACCENT

27W LED, 3500K, Tight Spot

Candela Curves

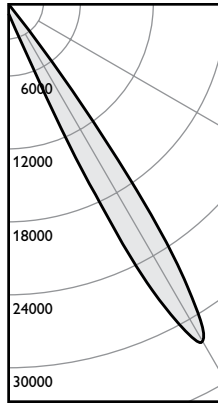

Frame: C4LA15NULD
Trim: C4L15A35K8TSP
Reflector: C4LACLW

Report no¹: 258GFR

Output lumens: 1727 lms
 CCT²: 3500K
 Input watts³: 27.2 W
 Efficacy: 63.5 lm/w
 CRI: 80 min
 Center Beam: 31,939 c.d.
 Beam Angle: 11°

30° Horizontal Aiming

Dist. (D)	Dist. (C)	F.C. (FC)	Beam Length (L)	Beam Width (W)
6	3.5	576	1.5	1.3
8	4.6	324	2.1	1.8
10	5.8	207	2.6	2.2
12	6.9	144	3.1	2.7

30° Vertical Aiming

Dist. (D)	Dist. (C)	F.C. (FC)	Beam Length (L)	Beam Width (W)
2	3.5	998	1.6	0.8
3	5.2	444	2.4	1.2
4	6.9	250	3.2	1.5
5	8.7	160	4.0	1.9

27W LED, 3500K, Spot

Candela Curves

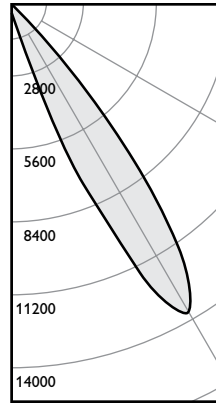

Frame: C4LA15NULD
Trim: C4L15A35K8SP
Reflector: C4LACLW

Report no¹: 259GFR

Output lumens: 1543 lms
 CCT²: 3500K
 Input watts³: 27.2 W
 Efficacy: 56.7 lm/w
 CRI: 80 min
 Center Beam: 13,659 c.d.
 Beam Angle: 17°

30° Horizontal Aiming

Dist. (D)	Dist. (C)	F.C. (FC)	Beam Length (L)	Beam Width (W)
6	3.5	246	2.4	2.1
8	4.6	139	3.2	2.8
10	5.8	89	4.0	3.5
12	6.9	62	4.8	4.1

30° Vertical Aiming

Dist. (D)	Dist. (C)	F.C. (FC)	Beam Length (L)	Beam Width (W)
2	3.5	427	2.6	1.2
3	5.2	190	3.8	1.8
4	6.9	107	5.1	2.4
5	8.7	68	6.4	3.0

27W LED, 3500K, Narrow Flood

Candela Curves

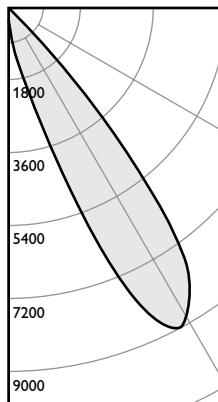

Frame: C4LA15NULD
Trim: C4L15A35K8NF
Reflector: C4LACLW

Report no¹: 260GFR

Output lumens: 1442 lms
 CCT²: 3500K
 Input watts³: 27.2 W
 Efficacy: 53.0 lm/w
 CRI: 80 min
 Center Beam: 9,103 c.d.
 Beam Angle: 22°

30° Horizontal Aiming

Dist. (D)	Dist. (C)	F.C. (FC)	Beam Length (L)	Beam Width (W)
6	3.5	164	3.1	2.7
8	4.6	92	4.2	3.6
10	5.8	59	5.2	4.5
12	6.9	41	6.3	5.4

30° Vertical Aiming

Dist. (D)	Dist. (C)	F.C. (FC)	Beam Length (L)	Beam Width (W)
2	3.5	284	3.5	1.6
3	5.2	126	5.3	2.3
4	6.9	71	7.0	3.1
5	8.7	46	8.8	3.9

27W LED, 3500K, Flood

Candela Curves

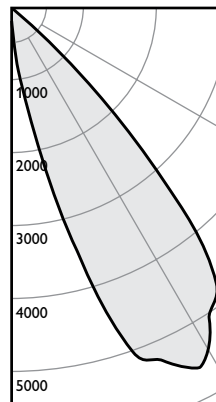

Frame: C4LA15NULD
Trim: C4L15A35K8FL
Reflector: C4LACLW

Report no¹: 261GFR

Output lumens: 1474 lms
 CCT²: 3500K
 Input watts³: 27.2 W
 Efficacy: 54.2 lm/w
 CRI: 80 min
 Center Beam: 5,648 c.d.
 Beam Angle: 29°

30° Horizontal Aiming

Dist. (D)	Dist. (C)	F.C. (FC)	Beam Length (L)	Beam Width (W)
6	3.5	102	4.2	3.6
8	4.6	57	5.6	4.8
10	5.8	37	7.1	6.0
12	6.9	25	8.5	7.2

30° Vertical Aiming

Dist. (D)	Dist. (C)	F.C. (FC)	Beam Length (L)	Beam Width (W)
2	3.5	177	5.2	2.1
3	5.2	78	7.8	3.1
4	6.9	44	10.4	4.1
5	8.7	28	12.9	5.2

1. Tested using absolute photometry as specified in LM79: IESNA Approved Method for the Electrical and Photometric Measurements of Solid-State Lighting Products.
 2. Correlated Color Temperature within specs as defined in ANSI_NEMA_ANSI C78.377-2008: Specifications for the Chromaticity of Solid State Lighting Products.
 3. Wattage controlled to within 5%.



© 2014 Koninklijke Philips N.V. All rights reserved.
 Specifications are subject to change without notice.
www.philips.com/luminaires

Philips Lighting
 North America Corporation
 200 Franklin Square Drive
 Somerset, NJ 08873
 Phone: 855-486-2216

Philips Lighting Company
 281 Hillmount Road
 Markham ON, Canada L6C 2S3
 Phone: 800-668-9008