

Bullyte (BT5016) Specification Sheet

Project Name:	Location:	MFG: Philips Hadco
Fixture Type:	Catalog No.:	Qty:

Ordering Guide

Example: BT5016 A

Product Code	BT5016	Bullyte
Finish	A H	Black Bronze

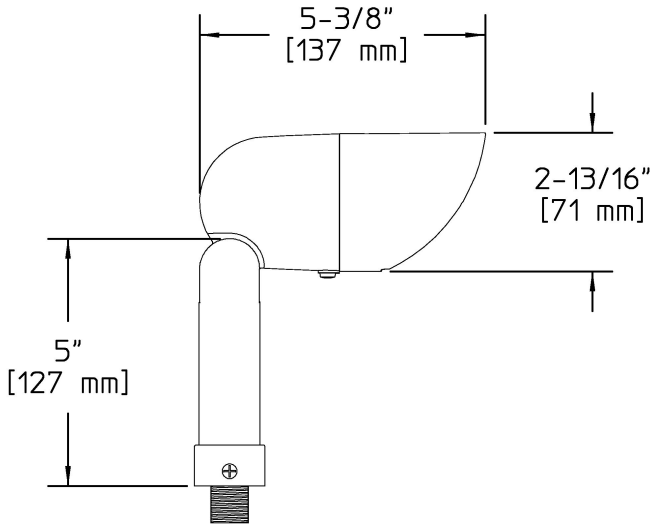

Specifications

HOUSING:

360 Die-cast marine grade aluminum. Fully-adjustable swivel arm with vibration-proof locking teeth. Fully rotatable shroud, double gasketed, die-cast marine grade alloy aluminum. Fasteners are 300 series stainless steel. 1/2" NPS male threads to screw onto accessory mounting stake or junction box, sold separately.

FINISH:

Thermoset polyester powdercoat is electrostatically applied after a five-stage conversion cleaning process and bonded by heat fusion thermosetting.

OPTICAL ASSEMBLY:

Clear tempered glass affixed at 10° angle for natural cleaning.

LAMPING:

50W maximum MR16 bi-pin lamp. Lamp is not included. Covered MR16 lamps are recommended to protect lamp's inner capsule. Lower wattage lamps are acceptable.

ELECTRICAL ASSEMBLY:

Bi-pin socket type (GU5.3) with 250° C high temperature teflon coated wire leads. Fixture is pre-wired with 18 AWG black, white, and ground wires. Step-down transformer reduces line voltage to 12 volts. Transformer is potted/encapsulated and features thermal overload protection. Can be used with energy-efficient halogen lamp.

WARRANTY:

Three-year limited warranty.

CERTIFICATIONS:

ETL listed to U.S. safety standards for wet locations. cETL listed to Canadian safety standards for wet locations. Manufactured to ISO 9001:2008 Standards.

Width:

2 13/16" (71mm)

Length:

5 3/8" (137mm)

Max. Weight:

1.2 lb.