

- ▶ Adjustable Ultra-bright 8W Bi-Pin Halogen Lamp Head
- ▶ Sealed Beam PAR36 type Gimbal Trim with smooth Chrome-Plated Metallized Reflector and Impact resistant Thermoplastic lens delivering optimal light distribution
- ▶ Dual 120/277 voltage
- ▶ Charge Rate/Power "ON" LED Indicator Light
- ▶ Push-to-test switch for mandated code compliance testing
- ▶ LVD (low voltage disconnect) prevents battery from deep discharge
- ▶ 6V 4.5ah Maintenance-free, Rechargeable Sealed Lead Acid battery
- ▶ Internal Solid-state Transfer Switch automatically connects the internal battery to lamp heads for minimum 90-minute emergency illumination
- ▶ Fully Automatic Solid-state, Dual-rate Charger initiates battery charging to recharge a discharged battery in 24 hours
- ▶ Steel Mounting Frame and housing
- ▶ Junction Box with 3/4" knockouts for AC input
- ▶ 6" Recessed Housing with mounting bar hangers
- ▶ Trim securely attached to housing with spring clips
- ▶ Compatible with drywall or drop ceiling mount installations, Mounting Bar Hangers included
- ▶ Meets UL924, NFPA 101 Life Safety Code, NEC & OSHA Codes
- ▶ Temperature Range: 68°F to 86°F
- ▶ UL 924 listed for damp locations
- ▶ 5 Year Warranty

Cat. No.	Trim Type	Housing/Trim Color	Ctn Qty
73160	Gimbal	White	4
73161	Gimbal	Black	4

Recessed Twin Head Emergency Lights

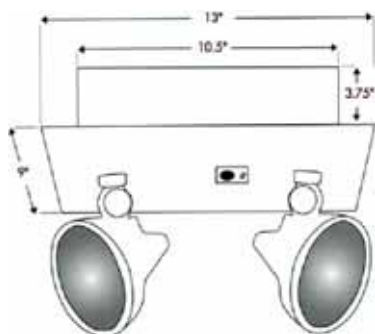

Recessed emergency lighting unit mounts flush with ceiling for a concealed, unobtrusive look

- ▶ Completely self-contained
- ▶ Compact, flush mount design
- ▶ Mounting bar hangers included
- ▶ 6-volt, pure lead, maintenance-free battery
- ▶ Environmentally-coated, solid state charger
- ▶ Automatic, low voltage disconnect (LVD)
- ▶ Universal transformer for 120 or 277 VAC
- ▶ Injection-Molded, V-O Flame Retardant, high impact, thermoplastic housing
- ▶ Charge rate/power on LED indicator light
- ▶ Push to test switch
- ▶ 90 minute emergency operation
- ▶ 6 Volt 7.2 Watt #939 lamp
- ▶ 5 Year Warranty

Cat. No.	Color	Case Qty
73158	White	6