



Manufactured in U.S.A.

Features & Specifications

CONSTRUCTION:

Heavy Gauge steel cabinet with powder coated finish and control compartment housing a master terminal board. The control compartment allows for access through a hinged and latched door, simplifying wiring, installation, and maintenance.

HEATING ELEMENT:

The heating element is a copper clad steel sheath element with continuously brazed steel fins formed to allow side draw through air flow.

OVERHEAT PROTECTION:

All units come equipped with manual reset type limit controls to de-energize the heater should an over-temperature situation occur.

FAN & MOTOR:

Single speed, single phase permanently lubricated, thermally protected motors with ball bearings. The fan override purges the unit of residual heat at shutdown.

FIELD INSTALLED OPTIONS:

Summer fan switch to operate the fan only, and a heat stratification thermostat for high bay areas.

HEATER STAGING:

60 KW and 70 KW are three stage; 80 KW, 90 KW, & 100 KW are four stage.

SC5100 FACTORY INSTALLED ELECTRONIC STEP CONTROLLER:

The optional factory installed step controller is a first on last off sequencer that will cycle the unit heater stages through an optional wall thermostat. Additionally, the step controller can be controlled by any building management system with 4 to 20 MA or 0 - 10 VDC field supplied control signal.

Optional Factory Installed Electronic Step Controller

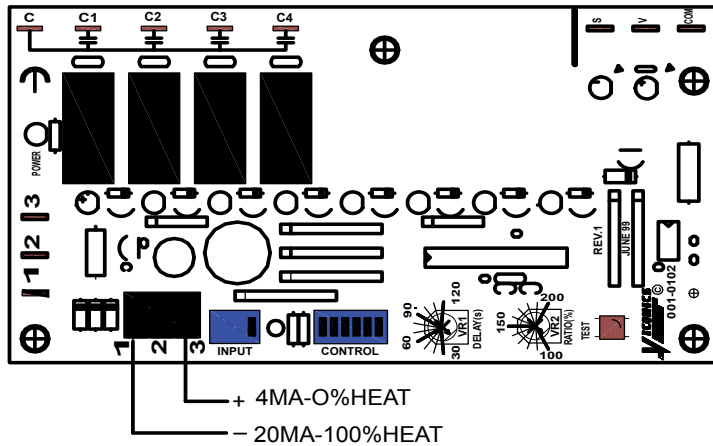

3 OR 4 STAGE
STEP CONTROL

0-10VDC-CONTROL
OR C1025 WALL
THERMOSTAT

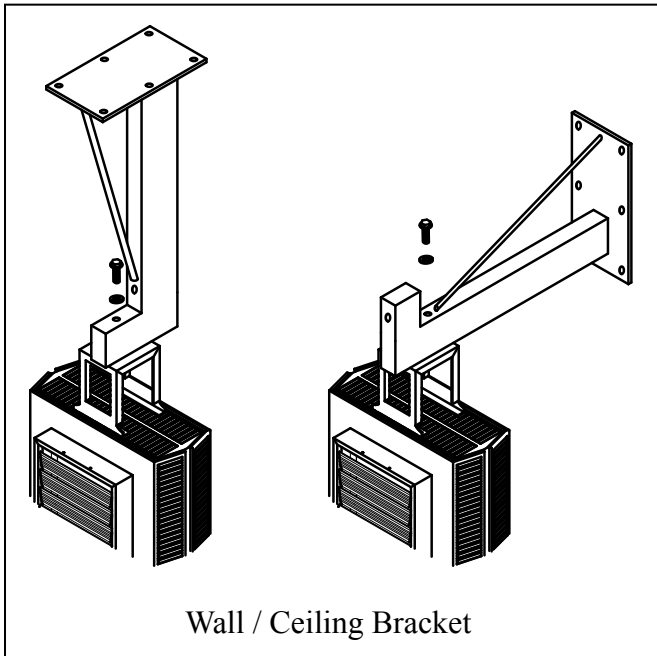

Dimensions

Dimensions (Inches)				WT (LBS.)
KW	H	W	D	
60-70	35 1/2	30 1/2	14 1/2	141
80-100	39 1/2	37 5/8	18 1/2	202

Mounting Brackets and Accessories

Mounting Brackets				
UPC#	Model	Heater KW	Description	LIST
686334				
7220002	A5175	60 To 70	Wall/Ceiling Bracket	181
7220102	A51100	80 to 100		189
7220302	B5175	60 to 70	Heater Bracket	82
7220402	B51100	80 to 100		101
7220202	V51100	60 to 100	Vertical Bracket	314
7220502	DS5175	60 to 70	Dust Shield	49
7220602	DS51100	80 to 100		57
7220902	OFG 5175	60 to 70	Fan Guard	78
7221002	OFG 51100	80 to 100		97