



# Two Channel Relay with Intrinsically Safe Outputs



## Specifications

### Electrical

**Supply Voltage:** 12 or 24 AC/DC  $\pm 10\%$   
**Power:** 1.5 watts  
**Inputs:** Switch Closure or Probe  
**Input Sensitivity:** 10k - 100k  $\Omega$   
**Pick-up & Drop-out Delays:** 0.5 second  
**Max. Open Circuit Voltage:** 5.9 volts DC  
**Max. Source Current:** 0.1 milliamps  
**Output Rating @ 25°C:**  
 5 Amps @ 125VAC  
 5 Amps @ 30VDC or 250VAC  
 20,000,000 Mechanical Cycles

### Physical

**Mounting:** Din Rail mount  
**Termination:** Touch safe screw terminals, with lift mechanism, #12 AWG max.  
**Weight:** 10 Oz.

### Ambient Temperatures

**Operating:** 0°C to 55°C  
**Storage:** -40°C to 85°C



### UL-913

Class 1, Division 1  
 Groups A, B, C, and D  
 Hazardous Locations

## Ordering Information

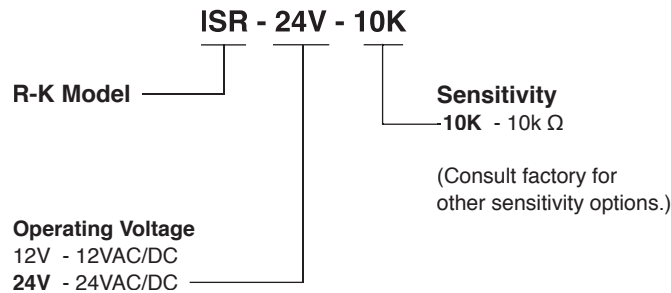

- 2 Independent Relays
- Compact Design
- Contact or Probe Input
- Built-in De-bounce Delays
- Power and Output status LEDs
- Low Voltage Design for 12 or 24VAC/DC
- Din Mounting
- 12 or 24VDC Battery Back-Up



E199046  
 Standard UL 913

## Connections

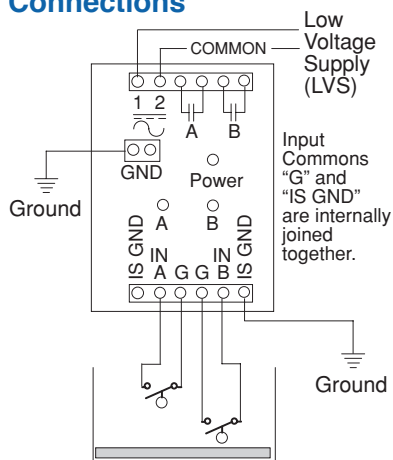

See control drawing A6757-4 for other input examples.

If Low Voltage Supply is grounded, the ground must be connected to terminal 2.

## Dimensions

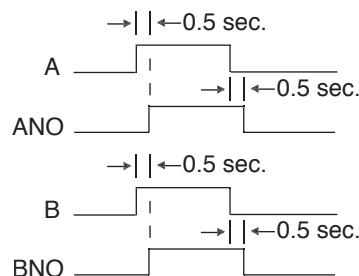
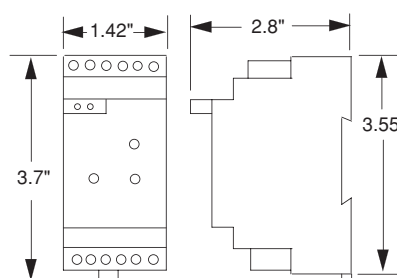

## Operation

### Two Channel Relay

The ISR has two independent outputs to the hazardous area and two independent (dry contact) relay outputs. The outputs to the hazardous area can be switches or, when used with a conductive liquid, electrodes. When output "A" is completed (contact closed or low resistance), 0.5 second later the dry output contact "A" is closed and the "A" LED turns On. When output "A" is opened (contact opened or high resistance), 0.5 second later the dry output contact "A" opens and the "A" LED turns Off. "B" operates the same way, but is independent of "A." There is also a supply power LED indicator. The ISR must be located and grounded in a non-hazardous location.

# Installation of Relays with Intrinsically Safe Outputs



Installation of these relays should only be performed by personnel experienced with intrinsically safe devices. Proper wiring practices must be strictly adhered to in order to prevent injury to personnel and property damage due to explosion or fire.

**IMPORTANT: BEFORE PROCEEDING TO INSTALL AND WIRE THE RELAY, READ AND THOROUGHLY UNDERSTAND THESE INSTRUCTIONS.**

When installed according to the following instructions and Control Drawing A-6757-4 these Relays are for use in Class I, Division 1, Groups A, B, C, and D. The relay must be mounted in a suitable enclosure which is tool accessible and is situated in a non hazardous area where an explosive atmosphere will not exist at any time.

## Wiring:

- All intrinsically safe wiring should be installed in accordance with NEC NFPA 70 Article 504 and ISA RP 12.6
- Electrical equipment connected to the non intrinsically safe side should not use or be capable of generating more than 250 volts with respect to earth.
- Intrinsically safe wiring connecting to the relay must be kept separate from non-intrinsically safe wiring by means of physical barriers and wiring tie down devices to insure no contact.
- The cabinet must have a proper earth ground and the relay must be grounded. At least one ground from the intrinsically safe side and the non intrinsically safe side of relay must be made using #12 AWG insulated conductors. The units redundant earth ground wires must be individually connected with metal screws and lockwashers to the cabinets earth ground. Resistance between the relay ground to the grounding electrode shall be less than one ohm.
- Intrinsically safe connections must not be made to any energy generating device or device mounted inside a tank subjected to pressures greater than 15 psi without specific approval.
- Maximum distance between the input of the relay and the switch is 1000 feet. Cable capacitance plus intrinsically safe equipment capacitance must be less than the marked capacitance ( $C_a$ ) shown on any barrier used. The same applies for inductance. We recommend the use of 14 AWG type THHN wire without splices. In no case should the capacitance or inductance exceed the specified limits. If the characteristics of your wire are unknown the following values may be used.  
  
CAPACITANCE: 60 pf / ft  
INDUCTANCE: 0.20  $\mu$ h / ft
- This device may be used in a Division 2. Location if so approved.
- Selected barriers must have  $V_{oc}$  not exceeding  $V_{max}$  and  $I_{sc}$  not exceeding  $I_{max}$  as shown below. All barriers must be of the same polarity.  
  
Entity parameters:  
 $V_{oc} = 5.89$  Volts  
 $I_{sc} = 0.132$  mA  
 $C_a = 0.45 \mu$ f  
 $L_a = 500$ mH  
 $V_{oc} \leq V_{max}$   
 $I_{sc} \leq I_{max}$   
 $C_a \geq C_l + C_{cable}$   
 $L_a \geq L_l + L_{cable}$

