

PowerFlex 750-Series AC Drives

Original Instructions



Topic	Page
Additional Resources	2
Product Overview	2
Certifications and Specifications	6
Design Considerations	11
Fuse and Circuit Breaker Ratings	40
Cable Considerations	63
Motor Considerations	65
Dimensions and Weights	68
Drive Options	127

Additional Resources

These documents contain additional information concerning related products from Rockwell Automation.

Title	Publication
PowerFlex 750-Series Drive Installation Instructions	750-IN001
PowerFlex 750-Series Programming Manual	750-PM001
Enhanced PowerFlex 7-Class Human Interface Module (HIM) User Manual	20HIM-UM001
PowerFlex 750-Series Safe Torque Off User Manual	750-UM002
Safe Speed Monitor Option Module for PowerFlex 750-Series AC Drives Reference Manual	750-RM001
PowerFlex 7-Class Network Communication Adapter User Manuals	750COM-UM
Dynamic Braking Resistor Calculator	PFLEX-AT001
Wiring and Grounding Guidelines for PWM AC Drives	DRIVES-IN001
Preventive Maintenance of Industrial Control and Drive System Equipment	DRIVES-TD001
Safety Guidelines for the Application, Installation and Maintenance of Solid-State Control	SGL-1.1

You can view or download publications at <http://www.rockwellautomation.com/literature/>. To order paper copies of technical documentation, contact your local Allen-Bradley distributor or Rockwell Automation sales representative.

Product Overview

The PowerFlex 750-Series is a robust family of AC drives that provide ease of use, flexibility, and performance for a variety of industrial applications. The PowerFlex 753 provides general-purpose control for applications ranging up to 400 Hp and 270 kW. The PowerFlex 755 provides maximum flexibility and performance ranging up to 2000 Hp and 1500 kW.

Maximize your productivity by taking advantage of the following key features offered in the PowerFlex 750-Series:

- **DeviceLogix™** – Embedded control technology that supports the manipulation of discrete outputs and drive control functions, while using discrete inputs and drive status information onboard the drive.
- **Predictive Diagnostics** – lets the drive keep track of information that affects the life of its cooling fans and relay outputs. The drive can also be programmed to monitor the runtime hours for machine or motor bearings.
- **Option Cards** – Each drive has a slot-based architecture. Supported hardware control options are common for both products, to help reduce your inventory and spare parts requirements.
- **Safe Torque Off and Safe Speed Monitor** – provides a choice for safety levels depending on your application requirements.
- **Communications** – The PowerFlex 755 comes with a built-in Ethernet port. Ethernet can easily be added to the PowerFlex 753 with a communication module.
- **I/O** – option cards are available for additional analog and digital I/O. The PowerFlex 753 comes with built-in I/O that can also be easily expanded with option cards.
- **Packaging** – Factory and field installable enclosure options are available to meet most environmental requirements: Open Type and Flange Mount options to support Cabinet Mount requirements, Extra Protection Wall Mount for harsh environments, and supporting debris hoods and conduit plate kits.
- **Standard Power Structure** – a common power structure is shared to provide the same physical footprint and power range.



PowerFlex 750-Series Drive Family



Wall Mount Frame 1...7

IP00/IP20, NEMA/UL Type Open Drive

Includes a DC link choke on all frames and internal brake transistor, standard on frames 1...5 and optional on frames 6 and 7.



Floor Mount Frames 8...10

IP20, NEMA/UL Type 1 Drive (2500 MCC Style Cabinet)

Includes a DC link choke, integrated AC line fuses and roll-out design. Hood shown on top of cabinets is optional, see [page 136](#) for ordering information.



Floor Mount Frames 8...10

IP20, NEMA/UL Type 1 Drive with Options (2500 MCC Style Cabinet)

Includes a DC link choke, integrated AC line fuses, roll-out design, and option bay for control/protection devices.



Roll-out Design
(Frame 8 shown)

A Roll-out Cart is required for frame 8...10 drives and frame 9...10 Option Bay Chassis. The cart has an adjustable curb height of 0...182 mm (0...7.2 in.) and curb offset/reach of 0...114 mm (0...4.5 in.).

See [page 136](#) for ordering information.

Catalog Number Explanation

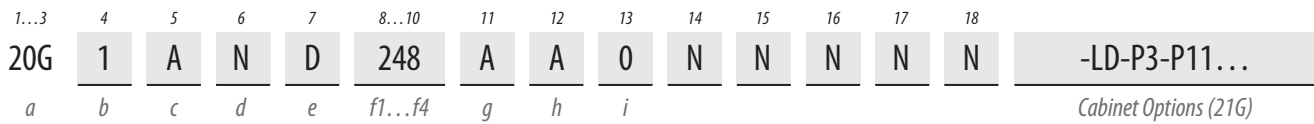

a

Drive		
Code	Type	Frames
20F	PowerFlex 753	1...7
20G	PowerFlex 755	1...10
21G	PowerFlex 755 Drive with Options	8...10

b

Future Use		
------------	--	--

c

Input Type		
Code	Description	Frames
1	AC Input with Precharge, includes DC Terminals	1...5 8 ⁽¹⁾ ...10
4	DC Input with Precharge	5...10
A	AC Input with Precharge, no DC Terminals	6...8 ⁽²⁾

- (1) Code 1 is only valid for frame 8 with the enclosure code "T".
- (2) The DC Bus Bar kit (20-750-DCBB1-Fx) is available for frames 6 and 7 AC input drives requiring DC bus terminals.

d

Enclosure		
Code	Description	Frames
R	IP20, NEMA/UL Type Open, Frame 1	1
F ⁽¹⁾	Flange (NEMA/UL Type 4X/12 back)	2...5
G	IP54, NEMA/UL Type 12	2...7
N ⁽²⁾	IP20/IP00, NEMA/UL Type Open	2...7
B ⁽³⁾	IP20, NEMA/UL Type 1, 600 mm (23.6 in.) Deep, Standard Cabinet Color (RAL 7032)	8...10
J ⁽³⁾	IP54, UL Type 12, 800 mm (31.5 in.) Deep, Standard Cabinet Color (RAL 7032)	8...10
K ⁽³⁾	IP54, NEMA 12, 2500 MCC Style Cabinet & Options w/MCC Power Bus, 800 mm (31.5 in.) Deep, Standard Cabinet Color (RAL 7032)	8...10
L ⁽³⁾	IP20, NEMA/UL Type 1, 800 mm (31.5 in.) Deep, Standard Cabinet Color (RAL 7032)	8...10
p ⁽³⁾	IP20, NEMA/UL Type 1, 2500 MCC Style Cabinet & Options w/MCC Power Bus, 800 mm (31.5 in.) Deep, Standard Cabinet Color (RAL 7032)	8...10
W ⁽³⁾	IP20, NEMA/UL Type 1, 2500 MCC Style Cabinet & Options w/MCC Power Bus, 800 mm (31.5 in.) Deep, CenterLine 2100 Gray (ASA49)	8...10
Y ⁽³⁾	IP54, NEMA 12, 2500 MCC Style Cabinet & Options w/MCC Power Bus, 800 mm (31.5 in.) Deep, CenterLine 2100 Gray (ASA49)	8...10
T	IP00, UL Open Type without Control POD	8...10

- (1) For frames 6 and 7 a user installed Flange kit (20-750-FLNG4-Fx) is available to convert a Code N drive that provides a NEMA/UL Type 4X/12 back.
- (2) Frames 2...5 are IP20, frames 6 and 7 are IP00.
- (3) Available as a drive with options (21G).

e

Voltage Rating	
Code	Voltage
C	400V AC/540V DC
D	480V AC/650V DC
E	600V AC/810V DC
F	690V AC/932V DC (not UL listed)

f1

ND Rating								
400V, 50 Hz Input								
Code	Amps	kW	Frame					
			Enclosure Code					
			B, J, L, T	F	G	N	K, P, W, Y	R

2P1	2.1	0.75						
3P5	3.5	1.5						
5P0	5.0	2.2						
8P7	8.7	4		2	2	2		1
011	11.5	5.5						
015	15.4	7.5						
022	22	11						
030	30	15						
037	37	18.5		3	3	3		
043	43	22						
060	60	30		4	4	4		
072	72	37			5			
085	85	45		5		5		
104	104	55				6		
140	140	75						
170	170	90						
205	205	110						
260	260	132		(1)				
302	302	160						
367	367	200			7	7		
456	456	250						
460	460	250	8				8 ⁽²⁾	
477	477	270		(1)		7		
540	540	315						
567	567	315						
650	650	355						
750	750	400						
770	770	400						
910	910	500						
1K0	1040	560						
1K1	1090	630						
1K2	1175	710						
1K4	1465	800						
1K5	1480	850						
1K6	1590	900						
2K1	2150	1250						
								10 ⁽²⁾

- (1) For frames 6 and 7 a user installed Flange kit (20-750-FLNG4-Fx) is available to convert a Code N drive that provides a NEMA/UL Type 4X/12 back.
- (2) Available as a drive with options (21G).

f2

ND Rating								
480V, 60 Hz Input								
Code	Amps	Hp	Frame					
			Enclosure Code					
			B, J, L, T	F	G	N	K, P, W, Y	R

2P1	2.1	1						
3P4	3.4	2						
5P0	5.0	3						
8P0	8.0	5		2	2	2		1
011	11	7.5						
014	14	10						
022	22	15						
027	27	20						
034	34	25		3	3	3		
040	40	30						
052	52	40		4	4	4		
065	65	50			5			
077	77	60		5		5		
096	96	75						
125	125	100						
156	156	125			6			
186	186	150						
248	248	200		(1)				
302	302	250			7	7		
361	361	300						
415	415	350						
430	430	350	8				8 ⁽²⁾	
477	477	400		(1)		7		
485	485	400						
545	545	450						
617	617	500						
710	710	600						
740	740	650						
800	800	700						
960	960	800						
1K0	1045	900						
1K2	1135	1000						
1K3	1365	1100						
1K4	1420	1250						
1K5	1525	1350						
2K0	2070	1750						
								10 ⁽²⁾

- (1) For frames 6 and 7 a user installed Flange kit (20-750-FLNG4-Fx) is available to convert a Code N drive that provides a NEMA/UL Type 4X/12 back.
- (2) Available as a drive with options (21G).

1...3 4 5 6 7 8...10 11 12 13 14 15 16 17 18
20G 1 A N D 248 A A O N N N N N -LD-P3-P11...
a b c d e f1...f4 g h i Cabinet Options (21G)

f3								
ND Rating								
600V, 60 Hz Input								
Code	Amps	Hp	Frame					R
			Enclosure Code					
			B, J, L, T	F	G	N	K, P, W, Y	
1P7	1.7	1						
2P7	2.7	2						
3P9	3.9	3						
6P1	6.1	5						
9P0	9	7.5						
011	11	10						
012 ⁽¹⁾	12	10						
017	17	15						
018 ⁽¹⁾	18	15						
022	22	20						
023 ⁽¹⁾	23	20						
024 ⁽¹⁾	24	20						
027	27	25						
028 ⁽¹⁾	28	25						
032	32	30						
033 ⁽¹⁾	33	30						
041	41	40						
042 ⁽¹⁾	42	40						
052	52	50						
053 ⁽¹⁾	53	50						
063	63	60						
077	77	75						
099	99	100						
125	125	125						
144	144	150						
192	192	200						
242	242	250						
289	289	300						
295	295	300						
355	355	350						
395	395	400						
435	435	450						
460	460	500						
510	510	500						
595	595	600						
630	630	700						
760	760	800						
825	825	900						
900	900	950						
980	980	1000						
1K1	1110	1100						
1K4	1430	1400						

f4								
ND Rating								
690V, 50 Hz Input (not UL listed)								
Code	Amps	kW	Frame					R
			Enclosure Code					
			B, J, L, T	F	G	N	K, P, W, Y	
012	12	7.5						
015	15	11						
020	20	15						
023	23	18.5						
030	30	22						
034	34	30						
046	46	37						
050	50	45						
061	61	55						
082	82	75						
098	98	90						
119	119	110						
142	142	132						
171	171	160						
212	212	200						
263	263	250						
265	265	250						
330	330	315						
370	370	355						
415	415	400						
460	460	450						
500	500	500						
590	590	560						
650	650	630						
710	710	710						
765	765	750						
795	795	800						
960	960	900						
1K0	1040	1000						
1K4	1400	1400						

- (1) For frames 6 and 7 a user installed Flange kit (20-750-FLNG4-Fx) is available to convert a Code N drive that provides a NEMA/UL Type 4X/12 back.
- (2) Available as a drive with options (21G).

g		
Filtering and CM Cap Configuration ⁽¹⁾		
Code	Filtering	Default CM Cap Connection
A	Yes	Jumper Removed
J	Yes	Jumper Installed

- (1) 480V drives must select code "A." Jumpers are included for field re-configuration as desired.

h		
Dynamic Braking ⁽¹⁾		
Code	Internal Resistor ⁽²⁾	Internal Transistor ⁽³⁾
A	No	Yes
N	No	No

- (1) Not available on frames 8...10, specify Code "N."
- (2) User-installed internal resistor kits (20-750-DB1-Dx) are available for frames 1 and 2.
- (3) Standard on frames 1...5, optional on 6 and 7.

i	
Door Mounted HIM (Frames 8...10)	
Code	Operator Interface
0	No Door Mounted HIM
2	Enhanced LCD, Full Numeric, IP20
4	Enhanced LCD, Full Numeric, IP66 NEMA Type 4X/12

PowerFlex 755 w/Options (21G)
Required Selections

Code	Option	Frames	Type
LD	Light Duty	8...10	System Overload Duty Cycle ⁽¹⁾
ND	Normal Duty		
HD	Heavy Duty		
P3	Input Thermal Magnetic Circuit Breaker	8...10	Power Disconnect ⁽¹⁾
P5	Input Non-Fused Molded Case Disconnect Switch	8 Only	
P14	Wiring Only Bay	8...10	Wiring Only Bay

- (1) Only one option of this type may be selected.

PowerFlex 755 w/Options (21G)
Additional Selections

Code	Option	Frames	Type
P11	Input Contactor	8 Only	Contactors ⁽¹⁾⁽²⁾
P12	Output Contactor	8 Only	
L1	3% Input Reactor	8 and 9	Reactors ⁽¹⁾
L2	3% Output Reactor		
L3	5% Input Reactor		
L4	5% Output Reactor	8 Only	
P20	1200 Amp Bus	8...10	MCC Power Bus Capacity ⁽¹⁾
P22	2000 Amp Bus		
P24	3000 Amp Bus		
P30	UPS Control Bus, DC Input w/Precharge only	8...10	UPS Control Bus
X1	Auxiliary Transformer (500VA available), IP20 Cabinet Only	8 Only ⁽³⁾	Auxiliary Power

- (1) Only one option of this type may be selected.
- (2) Contactor options are not available for systems with MCC power bus.
- (3) Standard on all other cabinet configurations.

- (1) Required for uncontrolled common DC bus applications. Optional for all AC applications.
- (2) For frames 6 and 7 a user installed Flange kit (20-750-FLNG4-Fx) is available to convert a Code N drive that provides a NEMA/UL Type 4X/12 back.
- (3) Available as a drive with options (21G).

Environmental Specifications

Category	Specification																										
Altitude: Based on Load: Based on Voltage:	See Derating Guidelines on pages 15 ... 38 . Altitude Limit Above Sea Level ⁽²⁾⁽⁵⁾																										
	<table border="1"> <thead> <tr> <th>System & Ground Configuration</th> <th>Overvoltage Category⁽¹⁾</th> <th>400/480V AC</th> <th>600V AC</th> <th>690V AC</th> </tr> </thead> <tbody> <tr> <td>Center Grounded (Y Neutral)</td> <td>II (2)</td> <td>9000 m⁽³⁾</td> <td>7500 m⁽³⁾</td> <td>7500 m⁽³⁾</td> </tr> <tr> <td>w/Solid Ground</td> <td>III (3)</td> <td>4800 m</td> <td>4800 m</td> <td>4800 m</td> </tr> <tr> <td>Ungrounded, Impedance⁽⁴⁾</td> <td>II (2)</td> <td>4800 m</td> <td>7500 m⁽³⁾</td> <td>4800 m</td> </tr> <tr> <td>Grounded, or Corner Grounded⁽⁴⁾</td> <td>III (3)</td> <td>2000 m</td> <td>4800 m</td> <td>2000 m</td> </tr> </tbody> </table>	System & Ground Configuration	Overvoltage Category ⁽¹⁾	400/480V AC	600V AC	690V AC	Center Grounded (Y Neutral)	II (2)	9000 m ⁽³⁾	7500 m ⁽³⁾	7500 m ⁽³⁾	w/Solid Ground	III (3)	4800 m	4800 m	4800 m	Ungrounded, Impedance ⁽⁴⁾	II (2)	4800 m	7500 m ⁽³⁾	4800 m	Grounded, or Corner Grounded ⁽⁴⁾	III (3)	2000 m	4800 m	2000 m	
System & Ground Configuration	Overvoltage Category ⁽¹⁾	400/480V AC	600V AC	690V AC																							
Center Grounded (Y Neutral)	II (2)	9000 m ⁽³⁾	7500 m ⁽³⁾	7500 m ⁽³⁾																							
w/Solid Ground	III (3)	4800 m	4800 m	4800 m																							
Ungrounded, Impedance ⁽⁴⁾	II (2)	4800 m	7500 m ⁽³⁾	4800 m																							
Grounded, or Corner Grounded ⁽⁴⁾	III (3)	2000 m	4800 m	2000 m																							
	<p>Notes: Based on EN61800-5-1 (Electro-thermal Safety Standard for drives)</p> <p>(1) Overvoltage Categories: Category II (Isolation Transformer Level) - Typically two levels of isolation or protection from outdoor power lines. Category III (Most Common) Distribution Level Inside a Building - Typically one level of isolation or protection from outdoor power lines.</p> <p>(2) Excluding failure from cosmic radiation. Cosmic radiation increases rate of IGBT malfunction at altitudes greater than 3000 m above sea level. Concrete walls and ceilings or concrete walls and large bottles of water overhead are examples of ways to shield against cosmic radiation.</p> <p>(3) Drive is limited to a maximum of 4800 m thermally. See the Ambient Temperature/Load Derating Guidelines starting on page 15.</p> <p>(4) In CE installations, frame 1 does not support ungrounded or corner grounded configurations.</p> <p>(5) Frame 1 drives are limited to a maximum of 2000 m thermally. See the Derating Guidelines starting on page 15.</p>																										
Maximum Surrounding Air Temperature IP20, NEMA/UL Open Type: IP00, NEMA/UL Open Type: IP20, NEMA/UL Type 1 (w/Hood): IP20, NEMA/UL Type 1 (w/Label): IP00, NEMA/UL Open Type IP20, NEMA/UL Type 1: IP54, NEMA 12: Flange Mount – Front: IP20, NEMA/UL Open Type: IP00, NEMA/UL Open Type: Back/Heat Sink: IP66, NEMA/UL Type 4X Stand-alone/Wall Mount – IP54, NEMA/UL Type 12	<table border="1"> <tbody> <tr> <td>0...50 °C (32...122 °F)</td> <td>Frames 1...5, All Ratings</td> </tr> <tr> <td>0...50 °C (32...122 °F)</td> <td>Frames 6 and 7, 12...456 A Ratings</td> </tr> <tr> <td>0...40 °C (32...104 °F)</td> <td>Frame 7, 477 A Rating</td> </tr> <tr> <td>0...40 °C (32...104 °F)</td> <td>Frames 1...5, All Ratings</td> </tr> <tr> <td>0...40 °C (32...104 °F)</td> <td>Frames 6 and 7, All Ratings</td> </tr> <tr> <td>0...40 °C (32...104 °F)⁽¹⁾</td> <td>Frames 8...10, All Ratings</td> </tr> <tr> <td>0...40 °C (32...104 °F)⁽¹⁾</td> <td>Frames 8...10, All Ratings</td> </tr> <tr> <td>0...40 °C (32...104 °F)⁽¹⁾</td> <td>Frames 8...10, All Ratings</td> </tr> <tr> <td>0...50 °C (32...122 °F)</td> <td>Frames 2...5, All Ratings</td> </tr> <tr> <td>0...50 °C (32...122 °F)</td> <td>Frames 6 and 7, 12...456 A Ratings</td> </tr> <tr> <td>0...40 °C (32...104 °F)</td> <td>Frame 7, 477 A Rating</td> </tr> <tr> <td>0...40 °C (32...104 °F)</td> <td>Frames 2...7, All Ratings</td> </tr> <tr> <td>0...40 °C (32...104 °F)</td> <td>Frames 2...7, All Ratings</td> </tr> </tbody> </table>	0...50 °C (32...122 °F)	Frames 1...5, All Ratings	0...50 °C (32...122 °F)	Frames 6 and 7, 12...456 A Ratings	0...40 °C (32...104 °F)	Frame 7, 477 A Rating	0...40 °C (32...104 °F)	Frames 1...5, All Ratings	0...40 °C (32...104 °F)	Frames 6 and 7, All Ratings	0...40 °C (32...104 °F) ⁽¹⁾	Frames 8...10, All Ratings	0...40 °C (32...104 °F) ⁽¹⁾	Frames 8...10, All Ratings	0...40 °C (32...104 °F) ⁽¹⁾	Frames 8...10, All Ratings	0...50 °C (32...122 °F)	Frames 2...5, All Ratings	0...50 °C (32...122 °F)	Frames 6 and 7, 12...456 A Ratings	0...40 °C (32...104 °F)	Frame 7, 477 A Rating	0...40 °C (32...104 °F)	Frames 2...7, All Ratings	0...40 °C (32...104 °F)	Frames 2...7, All Ratings
0...50 °C (32...122 °F)	Frames 1...5, All Ratings																										
0...50 °C (32...122 °F)	Frames 6 and 7, 12...456 A Ratings																										
0...40 °C (32...104 °F)	Frame 7, 477 A Rating																										
0...40 °C (32...104 °F)	Frames 1...5, All Ratings																										
0...40 °C (32...104 °F)	Frames 6 and 7, All Ratings																										
0...40 °C (32...104 °F) ⁽¹⁾	Frames 8...10, All Ratings																										
0...40 °C (32...104 °F) ⁽¹⁾	Frames 8...10, All Ratings																										
0...40 °C (32...104 °F) ⁽¹⁾	Frames 8...10, All Ratings																										
0...50 °C (32...122 °F)	Frames 2...5, All Ratings																										
0...50 °C (32...122 °F)	Frames 6 and 7, 12...456 A Ratings																										
0...40 °C (32...104 °F)	Frame 7, 477 A Rating																										
0...40 °C (32...104 °F)	Frames 2...7, All Ratings																										
0...40 °C (32...104 °F)	Frames 2...7, All Ratings																										
Storage Temperature (all const.):	-40...70 °C (-40...158 °F)																										
Atmosphere:	Important: Drive must not be installed in an area where the ambient atmosphere contains volatile or corrosive gas, vapors or dust. If the drive is not going to be installed for a period of time, it must be stored in an area where it is not exposed to a corrosive atmosphere.																										
UV Radiation	The HIM and IP54, NEMA/UL Type 12 drive plastics are not UV rated.																										
Relative Humidity:	5...95% non-condensing																										
Shock - Operating	<table border="1"> <tbody> <tr> <td>Frames 1...6:</td> <td>15 g peak for 11 ms duration (±1.0 ms)</td> </tr> <tr> <td>Frame 7:</td> <td>10 g peak for 11 ms duration (±1.0 ms)</td> </tr> <tr> <td>Frames 8...10:</td> <td>Power Core - 10 g peak for 11 ms duration (±1.0 ms) in Cabinet w/Option Bay - 5 g peak for 11 ms duration (±1.0 ms)</td> </tr> </tbody> </table>	Frames 1...6:	15 g peak for 11 ms duration (±1.0 ms)	Frame 7:	10 g peak for 11 ms duration (±1.0 ms)	Frames 8...10:	Power Core - 10 g peak for 11 ms duration (±1.0 ms) in Cabinet w/Option Bay - 5 g peak for 11 ms duration (±1.0 ms)																				
Frames 1...6:	15 g peak for 11 ms duration (±1.0 ms)																										
Frame 7:	10 g peak for 11 ms duration (±1.0 ms)																										
Frames 8...10:	Power Core - 10 g peak for 11 ms duration (±1.0 ms) in Cabinet w/Option Bay - 5 g peak for 11 ms duration (±1.0 ms)																										
Shock - Packaged for Shipment	<table border="1"> <tbody> <tr> <td>Frames 1 and 2:</td> <td>381 mm (15 in.) drop height</td> </tr> <tr> <td>Frames 3 and 4:</td> <td>330 mm (13 in.) drop height</td> </tr> <tr> <td>Frame 5:</td> <td>305 mm (12 in.) drop height</td> </tr> <tr> <td>Frames 6...10:</td> <td>Meets International Safe Transit Association (ISTA) test procedure 2B</td> </tr> </tbody> </table>	Frames 1 and 2:	381 mm (15 in.) drop height	Frames 3 and 4:	330 mm (13 in.) drop height	Frame 5:	305 mm (12 in.) drop height	Frames 6...10:	Meets International Safe Transit Association (ISTA) test procedure 2B																		
Frames 1 and 2:	381 mm (15 in.) drop height																										
Frames 3 and 4:	330 mm (13 in.) drop height																										
Frame 5:	305 mm (12 in.) drop height																										
Frames 6...10:	Meets International Safe Transit Association (ISTA) test procedure 2B																										

(1) Maximum surrounding air temperature of 50 °C (122 °F) with derating. See Derating Guidelines on [page 15](#).

Environmental Specifications (continued)

Category	Specification																								
Vibration - Operating	Frames 1 and 2: 1.000 mm (0.040 in.) displacement, 2 g peak Frames 3...5: 1.000 mm (0.040 in.) displacement, 1.5 g peak Frames 6 and 7: 1.000 mm (0.040 in.) displacement, 1 g peak Frames 8...10: Power Core, Drive in Cabinet w/Option Bay - 1.000 mm (0.040 in.) displacement, 1 g peak																								
Vibration - Packaged for Shipment																									
Sinusoidal Loose Load:	Frames 1...5: 20.0 mm (0.8 in.) peak to peak, 2...5.186 Hz; 1.1 g peak from 5.186...20 Hz Frames 6...10: Meets ISTA 2B packaging standards																								
Random Secured:	Frames 1...5: <table border="1"> <thead> <tr> <th>Frequency (Hz)</th> <th>PSD (g²/Hz)</th> </tr> </thead> <tbody> <tr><td>1</td><td>0.00005</td></tr> <tr><td>4</td><td>0.01</td></tr> <tr><td>16</td><td>0.01</td></tr> <tr><td>40</td><td>0.001</td></tr> <tr><td>80</td><td>0.001</td></tr> <tr><td>200</td><td>0.00001</td></tr> </tbody> </table>	Frequency (Hz)	PSD (g ² /Hz)	1	0.00005	4	0.01	16	0.01	40	0.001	80	0.001	200	0.00001										
Frequency (Hz)	PSD (g ² /Hz)																								
1	0.00005																								
4	0.01																								
16	0.01																								
40	0.001																								
80	0.001																								
200	0.00001																								
	Frames 6...10: Meets International Safe Transit Association (ISTA) test procedure 2B																								
Required Airflow:	<table border="1"> <thead> <tr> <th>Frame</th> <th>Total Fan Air Flow</th> <th>Frame</th> <th>Total Fan Air Flow</th> </tr> </thead> <tbody> <tr><td>1 and 2</td><td>84.95 m³/h (50 CFM)</td><td>7</td><td>1284.45 m³/h (756 CFM)</td></tr> <tr><td>3</td><td>135.92 m³/h (80 CFM)</td><td>8</td><td>2293.67 m³/h (1350 CFM)</td></tr> <tr><td>4</td><td>543.68 m³/h (320 CFM)</td><td>9</td><td>4587.33 m³/h (2700 CFM)</td></tr> <tr><td>5</td><td>883.49 m³/h (520 CFM)</td><td>10</td><td>6880.99 m³/h (4050 CFM)</td></tr> <tr><td>6</td><td>856.30 m³/h (504CFM)</td><td></td><td></td></tr> </tbody> </table>	Frame	Total Fan Air Flow	Frame	Total Fan Air Flow	1 and 2	84.95 m ³ /h (50 CFM)	7	1284.45 m ³ /h (756 CFM)	3	135.92 m ³ /h (80 CFM)	8	2293.67 m ³ /h (1350 CFM)	4	543.68 m ³ /h (320 CFM)	9	4587.33 m ³ /h (2700 CFM)	5	883.49 m ³ /h (520 CFM)	10	6880.99 m ³ /h (4050 CFM)	6	856.30 m ³ /h (504CFM)		
Frame	Total Fan Air Flow	Frame	Total Fan Air Flow																						
1 and 2	84.95 m ³ /h (50 CFM)	7	1284.45 m ³ /h (756 CFM)																						
3	135.92 m ³ /h (80 CFM)	8	2293.67 m ³ /h (1350 CFM)																						
4	543.68 m ³ /h (320 CFM)	9	4587.33 m ³ /h (2700 CFM)																						
5	883.49 m ³ /h (520 CFM)	10	6880.99 m ³ /h (4050 CFM)																						
6	856.30 m ³ /h (504CFM)																								
Sound:	<table border="1"> <thead> <tr> <th>Frame</th> <th>Sound Level</th> <th>Frame</th> <th>Sound Level</th> </tr> </thead> <tbody> <tr><td>1 and 2</td><td>63 dB</td><td>7</td><td>74 dB</td></tr> <tr><td>3</td><td>64 dB</td><td>8</td><td>79 dB</td></tr> <tr><td>4</td><td>72 dB</td><td>9</td><td>79 dB</td></tr> <tr><td>5</td><td>77 dB</td><td>10</td><td>83 dB</td></tr> <tr><td>6</td><td>73 dB</td><td></td><td></td></tr> </tbody> </table> <p>Note: Sound pressure level is measured at 2 meters.</p>	Frame	Sound Level	Frame	Sound Level	1 and 2	63 dB	7	74 dB	3	64 dB	8	79 dB	4	72 dB	9	79 dB	5	77 dB	10	83 dB	6	73 dB		
Frame	Sound Level	Frame	Sound Level																						
1 and 2	63 dB	7	74 dB																						
3	64 dB	8	79 dB																						
4	72 dB	9	79 dB																						
5	77 dB	10	83 dB																						
6	73 dB																								
Surrounding Environment Pollution Degree	(See page 70 for descriptions of each pollution degree rating.)																								
Pollution Degree 1 & 2:	All enclosures acceptable.																								
Pollution Degree 3 & 4:	Enclosure that meets or exceeds IP54, NEMA/UL Type 12 required.																								

Technical Specifications

Category	Specification	
Protection	Motor Voltage	
	380/400	
	480V	
	600V	
	690V	
	AC Input Overvoltage Trip:	576V AC 576V AC 825V AC 825V AC
	AC Input Undervoltage Trip:	250V AC 300V AC 400V AC 400V AC
	Bus Overvoltage Trip:	815V DC 815V DC 1167V DC 1167V DC
	Bus Undervoltage Shutoff:	
	Frames 1...7:	200V DC 200V DC 200V DC (frames 3...7)
Frames 8...10:	400V DC 400V DC 400V DC 200V DC (frames 6 and 7) 400V DC	
Nominal Bus Voltage (Full Load):	540V DC 648V DC 810V DC 932V DC	
Drive Overcurrent Trip		
Software Overcurrent Trip:	200% of drive rated	
Instantaneous Current Limit:	100% of 3 sec. rating (158...210%)	
Hardware Overcurrent Trip:	143% of 3 sec. rating (215...287%)	
Line transients:	up to 6000 volts peak per IEEE C62.41-1991	
Control Logic Noise Immunity:	Showering arc transients up to 1500V peak	

Technical Specifications (continued)

Category	Specification																		
Protection (continued)	Power Ride-Thru:	15 milliseconds at full load																	
	Logic Control Ride-Thru:	0.5 seconds minimum, 2 seconds typical																	
	Ground Fault Trip:	Phase-to-ground on drive output																	
	Short Circuit Trip:	Phase-to-phase on drive output																	
Electrical	AC Input Voltage Tolerance:	See page 11 for full power and operating range.																	
	Frequency Tolerance:	47...63 Hz																	
	Input Phases:	Three-phase input provides full rating for all drives. For frames 1...7 (output current up to 456A), single-phase operation provides up to 50% of rated current at 25 °C (77 °F) surrounding temperature. Single-phase operation is not recommended for frames 8 and larger.																	
	DC Input Voltage Tolerance:	±10% of Nominal Bus Voltage (above)																	
	Displacement Power Factor:	0.98 across entire speed range																	
	DC Link Impedance:	≥ 5%																	
	Efficiency:	97.5% at rated amps, nominal line volts																	
	Maximum Short Circuit Rating:	200,000 Amps RMS symmetrical (20F & 20G drives only)																	
	Actual Short Circuit Rating:	Determined by AIC rating of installed fuse/circuit breaker. See page 57 for 21G drives.																	
	Drive to Motor Power Ratio Minimum: Maximum:	Recommended not less than 1:2 ratio Recommended not greater than 2:1 ratio																	
	Brake IGBT Rating:	100% of motor rated torque																	
	Control POD Current Draw:	5A																	
	Digital Inputs Nominal: Maximum: High State: Low State:	<table border="1"> <thead> <tr> <th>DC</th> <th>AC</th> </tr> </thead> <tbody> <tr> <td>24V DC</td> <td>120V AC</td> </tr> <tr> <td>30V DC</td> <td>132V AC</td> </tr> <tr> <td>20...24V DC</td> <td>100...132V AC</td> </tr> <tr> <td>0...5V DC</td> <td>0...30V AC</td> </tr> </tbody> </table>	DC	AC	24V DC	120V AC	30V DC	132V AC	20...24V DC	100...132V AC	0...5V DC	0...30V AC							
	DC	AC																	
24V DC	120V AC																		
30V DC	132V AC																		
20...24V DC	100...132V AC																		
0...5V DC	0...30V AC																		
PTC Inputs Standard: Trip Resistance: Nominal Resistance: Reset Resistance: Short Circuit Trip Resistance:	<table border="1"> <thead> <tr> <th>PF753 MCB</th> <th>22-Series I/O</th> <th>ATEX Option Module for 11-Series I/O</th> </tr> </thead> <tbody> <tr> <td>N/A⁽¹⁾</td> <td>DIN 44082</td> <td>IEC 6094-8</td> </tr> <tr> <td>3.1 kΩ</td> <td>3.1 kΩ</td> <td>3.2 kΩ</td> </tr> <tr> <td>1.8 kΩ</td> <td>1.8 kΩ</td> <td>1.6 kΩ</td> </tr> <tr> <td>2.2 kΩ</td> <td>2.2 kΩ</td> <td>N/A⁽³⁾</td> </tr> <tr> <td>N/A⁽²⁾</td> <td>300 Ω</td> <td>100 Ω</td> </tr> </tbody> </table> <p>(1) Not designed to a standard. (2) No short circuit fault. (3) No hysteresis, fault is latched.</p>	PF753 MCB	22-Series I/O	ATEX Option Module for 11-Series I/O	N/A ⁽¹⁾	DIN 44082	IEC 6094-8	3.1 kΩ	3.1 kΩ	3.2 kΩ	1.8 kΩ	1.8 kΩ	1.6 kΩ	2.2 kΩ	2.2 kΩ	N/A ⁽³⁾	N/A ⁽²⁾	300 Ω	100 Ω
PF753 MCB	22-Series I/O	ATEX Option Module for 11-Series I/O																	
N/A ⁽¹⁾	DIN 44082	IEC 6094-8																	
3.1 kΩ	3.1 kΩ	3.2 kΩ																	
1.8 kΩ	1.8 kΩ	1.6 kΩ																	
2.2 kΩ	2.2 kΩ	N/A ⁽³⁾																	
N/A ⁽²⁾	300 Ω	100 Ω																	
Battery:	User installed CR1220 lithium coin cell battery provides power to the real-time clock (optional, not supplied). Preserves the clock setting in the event power to the drive is lost or cycled. Approximate life is 4.5 years with drive unpowered, or lifetime if drive is powered.																		

Technical Specifications (continued)

Category	Specification	
Control	Method:	Sine coded PWM with programmable carrier frequency. Ratings apply to all drives.
	Carrier Frequency:	Default Settings: Frames 1...3: 4 kHz Frames 4...10: 2 kHz Settings: Frames 1...6: 2, 4, 8, 12 kHz Frame 7: 2, 4, 8 kHz Frames 8...10: 2, 4 kHz
	Output Voltage Range:	0 to rated motor voltage
	Output Frequency Range:	0...325 Hz @ 2 kHz carrier 0...590 Hz @ 4 kHz carrier
	Frequency Accuracy Digital Input: Analog Input:	Within $\pm 0.01\%$ of set output frequency Within $\pm 0.4\%$ of maximum output frequency
	Frequency Control:	Speed regulation - with Slip Compensation (V/Hz & Sensorless Vector modes) 0.5% of base speed across 40:1 speed range, 40:1 operating range
	Speed Control:	Without feedback (Flux Vector mode), 0.1% of base speed across 100:1 speed range, 120:1 operating range, 50 rad/sec bandwidth
		With feedback (Flux Vector mode), 0.001% of base speed across 100:1 speed range, 1000:1 operating range, 190 rad/sec bandwidth
	Torque Regulation:	Without feedback (Flux Vector mode), $\pm 5\%$, 600 rad/sec bandwidth
		With feedback (Flux Vector mode), $\pm 2\%$, 2500 rad/sec bandwidth
	Selectable Motor Control:	<ul style="list-style-type: none"> - Standard V/Hz with full custom capability - Sensorless Vector with full tuning - Flux Vector with and without a feedback device - Induction motor control - Surface mount permanent magnet motor control with encoder feedback (frames 1...10)⁽¹⁾ - Surface mount permanent magnet motor control without encoder feedback (frames 1...7)⁽¹⁾ - Internal permanent magnet motor control with encoder feedback (frames 1...10) - Internal permanent magnet motor control without encoder feedback (frames 1...7)
	Stop Modes:	Multiple programmable stop modes including - Ramp, Coast, DC-Brake, Ramp-to-Hold, Fast Braking, and Current Limit Stop.
	Accel/Decel:	Two independently programmable accel and decel times. Each time can be programmed from 0 to 3600 seconds in 0.1 second increments (0 to motor nameplate speed).
	S-curve Time	Adjustable from 0 to 100% of ramp time (normal duty rating)
	Intermittent Overload: Light Duty (Frames 8...10 Only) Normal Duty Heavy Duty	110% Overload capability for up to 1 minute out of 10 minutes
110% Overload capability for up to 1 minute out of 10 minutes 150% Overload capability for up to 3 seconds out of 60 seconds		
150% Overload capability for up to 1 minute out of 10 minutes 180% Overload capability for up to 3 seconds out of 60 seconds		
Current Limit Capability:	Proactive Current Limit programmable from 20 to 160% of rated output current. Independently programmable proportional and integral gain.	
Electronic Motor Overload Protection:	Class 10 motor overload protection according to NEC article 430 and motor over-temperature protection according to NEC article 430.126 (A)(2). UL 508C File E59272.	

(1) PowerFlex 755 only.

Design Considerations

Input Voltage Tolerance

Drive Rating	Nominal Line Voltage	Nominal Motor Voltage	Drive Full Power Range	Drive Operating Range
380...480	380	380	380...528	342...528
	400	400	400...528	
	480	460	460...528	
600...690	600	575	575...759	517...759
	690	660	660...759	

Drive Full Power Range = Nominal Motor Voltage to Drive Rated Voltage + 10%. Rated current is available across the entire Drive Full Power Range

Drive Operating Range = Lowest Nominal Motor Voltage - 10% to Drive Rated Voltage + 10%. Drive Output is linearly derated when Actual Line Voltage is less than the Nominal Motor Voltage

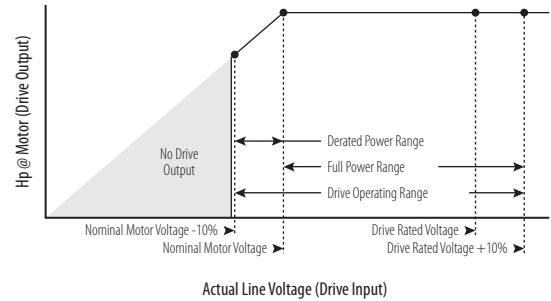

EXAMPLE Calculate the maximum power of a 5.0 Hp, 460V motor connected to a 480V rated drive supplied with 342V Actual Line Voltage input.

- Actual Line Voltage / Nominal Motor Voltage = 74.3%
- 74.3% x 5.0 Hp = 3.7 Hp
- 74.3% x 60 Hz = 44.6 Hz

At 342V Actual Line Voltage, the maximum power the 5.0 Hp, 460V motor can produce is 3.7 Hp at 44.6 Hz.

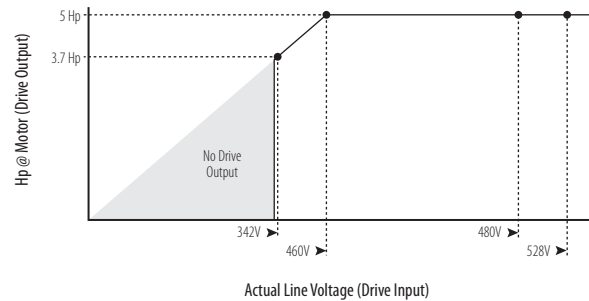

IMPORTANT For maximum protection of the drive and its internal components, Rockwell Automation prefers the use of fast acting semiconductor fuses to other methods of circuit protection. This reduces risk of drive damage from power quality events, and improves machine and process utilization, thus maximizing productivity.

Approximate Watts Loss

The following table lists watts loss data for PowerFlex 750-Series drives running at full load, full speed and default carrier frequency.

Internal watts are those dissipated by the control structure of the drive and are dissipated into the cabinet regardless of mounting style. External watts are those dissipated directly through the heatsink and are outside the cabinet for flange mount and inside the cabinet for other mounting types.

Watts Loss for 400/480V Drives

Drive Catalog Number ⁽¹⁾⁽²⁾	Normal Duty		External Watts ⁽³⁾	Internal Watts ⁽³⁾	Total Watts ⁽³⁾	Drive Catalog Number ⁽¹⁾⁽²⁾	Normal Duty		External Watts ⁽³⁾	Internal Watts ⁽³⁾	Total Watts ⁽³⁾
	kW	Cont. Output Amps					Hp	Cont. Output Amps			
400 Volt						480 Volt					
20x...C2P1	0.75	2.1	16 (16)	55 (56)	71 (72)	20x...D2P1	1.0	2.1	17 (21)	60 (61)	77 (82)
20x...C3P5	1.5	3.5	26 (33)	57 (60)	83 (93)	20x...D3P4	2.0	3.4	27 (39)	61 (64)	88 (103)
20x...C5P0	2.2	5	39 (44)	58 (62)	97 (106)	20x...D5P0	3.0	5	41 (54)	63 (67)	104 (121)
20x...C8P7	4.0	8.7	75 (79)	64 (80)	139 (159)	20x...D8P0	5.0	8	71 (91)	68 (82)	139 (173)
20x...C011	5.5	11.5	108 (107)	70 (85)	178 (192)	20x...D011	7.5	11	108 (118)	74 (88)	182 (206)
20x...C015	7.5	15.4	161 (166)	80 (80)	241 (246)	20x...D014	10	14	149 (152)	81 (81)	230 (233)
20x...C022	11	22	225	86	311	20x...D022	15	22	237	91	328
20x...C030	15	30	300	103	403	20x...D027	20	27	273	101	374
20x...C037	18.5	37	362	115	477	20x...D034	25	34	368	115	483
20x...C043	22	43	505	126	631	20x...D040	30	40	503	126	629
20x...C060	30	60	487	130	617	20x...D052	40	52	422	125	547
20x...C072	37	72	615	147	762	20x...D065	50	65	559	144	703
20x...C085	45	85	705	162	867	20x...D077	60	77	646	158	804
20x...C104	55	104	928	201	1129	20x...D096	75	96	855	189	1044
20x...C140	75	140	1239	319	1558	20x...D125	100	125	1109	299	1408
20x...C170	90	170	1381	300	1681	20x...D156	125	156	1299	294	1593
20x...C205	110	205	1893	381	2274	20x...D186	150	186	1718	358	2076
20x...C260	132	260	2449	502	2951	20x...D248	200	248	2384	492	2876
20x...C302	160	302	2566	461	3027	20x...D302	250	302	2704	491	3195
20x...C367	200	367	3322	586	3908	20x...D361	300	361	3409	606	4015
20x...C456	250	456	3922	743	4665	20x...D415	350	415	3604	683	4287
2xG...C460	250	460	4779	1090	5869	2xG...D430	350	430	4385	971	5356
20x...C477	270	477	4199	793	4992	20x...D477	400	477	4392	828	5220
2xG...C540	315	540	5316	1216	6532	2xG...D485	400	485	5091	1126	6217
2xG...C567	315	567	5652	1298	6950	2xG...D545	450	545	5649	1253	6902
2xG...C650	355	650	7011	1577	8588	2xG...D617	500	617	6942	1489	8431
2xG...C750	400	750	7577	1726	9303	2xG...D710	600	710	7631	1659	9290
2xG...C770	400	770	8086	1848	9934	2xG...D740	650	740	8133	1776	9909
2xG...C910	500	910	9155	2251	11406	2xG...D800	700	800	8710	2216	10926
2xG...C1K0	560	1040	9732	2357	12089	2xG...D960	800	960	9696	2391	12087
2xG...C1K1	630	1090	10745	2548	13293	2xG...D1K0	900	1045	10784	2589	13373
2xG...C1K2	710	1175	13778	2978	16756	2xG...D1K2	1000	1135	13378	2899	16277
2xG...C1K4	800	1465	13959	3013	16973	2xG...D1K3	1100	1365	14055	3025	17080
2xG...C1K5	850	1480	15441	3308	18749	2xG...D1K4	1250	1420	15573	3314	18887
2xG...C1K6	900	1590	15569	3717	19286	2xG...D1K5	1350	1525	15619	3779	19398
2xG...C2K1	1250	2150	22320	4790	27110	2xG...D2K0	1750	2070	22495	4802	27297

(1) Select watts loss based on catalog number.

(2) Frame 8...10 enclosure code B, J, L, P, and W.

(3) Frame 1 watts loss in parentheses.

Watts Loss for 600/690V Drives

Drive Catalog Number ⁽¹⁾⁽²⁾	Normal Duty		External Watts	Internal Watts	Total Watts	Drive Catalog Number ⁽¹⁾⁽²⁾	Normal Duty		External Watts	Internal Watts	Total Watts
	kW	Cont. Output Amps					Hp	Cont. Output Amps			
690 Volt						600 Volt					
						20x...E1P7	1.0	1.7	23	15	38
						20x...E2P7	2.0	2.7	40	17	57
						20x...E3P9	3.0	3.9	51	18	69
						20x...E6P1	5.0	6.1	80	22	103
						20x...E9P0	7.5	9	122	29	150
						20x...E011	10	11	152	34	186
20x...F012	7.5	12	169	50	219	20x...E012	10	12	168	50	217
						20x...E017	15	17	249	54	302
20x...F015	11	15	226	56	282	20x...E018	15	18	269	61	331
						20x...E022	20	22	329	74	403
20x...F020	15	20	296	65	361	20x...E023	20	23	332	70	403
20x...F023	18.5	23	327	70	397	20x...E024	20	24	326	71	397
						20x...E027	25	27	411	84	494
20x...F030	22	30	428	85	513	20x...E028	25	28	375	79	453
						20x...E032	30	32	503	105	608
20x...F034	30	34	478	94	573	20x...E033	30	33	439	90	528
						20x...E041	40	41	590	128	718
20x...F046	37	46	649	126	775	20x...E042	40	42	555	112	667
						20x...E052	50	52	784	176	959
20x...F050	45	50	699	138	836	20x...E053	50	53	711	144	855
20x...F061	55	61	760	130	891	20x...E063	60	63	757	132	889
20x...F082	75	82	1044	182	1226	20x...E077	75	77	935	166	1101
20x...F098	90	98	1310	231	1541	20x...E099	100	99	1269	229	1499
20x...F119	110	119	1658	302	1961	20x...E125	125	125	1678	318	1996
20x...F142	132	142	2003	387	2391	20x...E144	150	144	1960	389	2349
20x...F171	160	171	2655	389	3044	20x...E192	200	192	2801	433	3234
20x...F212	200	212	3375	513	3889	20x...E242	250	242	3642	593	4235
20x...F263	250	263	4286	690	4976	20x...E289	300	289	4437	762	5200
2xG...F265	250	265	4314	996	5310	2xG...E295	300	295	4592	1030	5622
2xG...F330	315	330	5160	1127	6287	2xG...E355	350	355	5191	1131	6321
2xG...F370	355	370	5803	1233	7036	2xG...E395	400	395	5812	1240	7052
2xG...F415	400	415	5865	1211	7076	2xG...E435	450	435	5590	1163	6753
2xG...F460	450	460	6638	1337	7975	2xG...E460	500	460	6407	1301	7708
2xG...F500	500	500	7117	1417	8534	2xG...E510	500	510	6946	1396	8342
2xG...F590	560	590	8941	2077	11019	2xG...E595	600	595	8903	2053	10956
2xG...F650	630	650	9865	2220	12085	2xG...E630	700	630	9942	2225	12167
2xG...F710	710	710	11136	2425	13561	2xG...E760	800	760	11093	2424	13517
2xG...F765	750	765	11139	2368	13507	2xG...E825	900	825	11046	2342	13389
2xG...F795	800	795	12663	2611	15275	2xG...E900	950	900	12225	2539	14764
2xG...F960	900	860	13608	2767	16375	2xG...E980	1000	980	13211	2709	15920
2xG...F1K0	1000	1040	16147	3545	19692	2xG...E1K1	1100	1110	16169	3552	19720
2xG...F1K4	1400	1400	19716	4034	23750	2xG...E1K4	1400	1430	19256	3966	23222

(1) Select watts loss based on catalog number.

(2) Frame 8...10 enclosure code B, L, P, and W.

Additional Watts Loss for Cabinet Options Bay

Drive Catalog Number ⁽¹⁾	Normal Duty		Cabinet Options Bay		Drive Catalog Number ⁽¹⁾	Normal Duty		Cabinet Options Bay	
	kW	Cont. Output Amps	without Input or Output Line Reactor (Watts) ⁽²⁾	with Input or Output Line Reactor (Watts) ⁽²⁾		Hp	Cont. Output Amps	without Input or Output Line Reactor (Watts) ⁽²⁾	with Input or Output Line Reactor (Watts) ⁽²⁾
400V					480V				
21G...C460	250	460	219	626	21G...D430	350	430	177	652
21G...C540	315	540	256	735	21G...D485	400	485	204	652
21G...C567	315	567	280	792	21G...D545	450	545	239	725
21G...C650	355	650	359	1123	21G...D617	500	617	295	983
21G...C750	400	750	404	1549	21G...D710	600	710	355	1410
21G...C770	400	770	441	1692	21G...D740	650	740	388	1542
21G...C910	500	910	327	2425	21G...D800	700	800	246	1867
21G...C1K0	560	1040	350	2651	21G...D960	800	960	364	2325
21G...C1K1	630	1090	384	2912	21G...D1K0	900	1045	353	2677
21G...C1K2	710	1175	446	3384	21G...D1K2	1000	1135	416	3158
21G...C1K4	800	1465	662	3520	21G...D1K3	1100	1365	574	3056
21G...C1K5	850	1480	675	3593	21G...D1K4	1250	1420	622	3307
690V					600V				
21G...F265	250	265	266	1090	21G...E295	300	295	233	838
21G...F330	315	330	304	1067	21G...E355	350	355	289	902
21G...F370	355	370	343	1288	21G...E395	400	395	328	759
21G...F415	400	415	379	1547	21G...E435	450	435	354	1208
21G...F460	450	460	240	1195	21G...E460	500	460	379	1327
21G...F500	500	500	251	1315	21G...E510	500	510	246	775
21G...F590	560	590	134	2617	21G...E595	600	595	136	1659
21G...F650	630	650	162	3175	21G...E630	700	630	153	1860
21G...F710	710	710	194	2362	21G...E760	800	760	222	2706
21G...F765	750	765	225	2742	21G...E825	900	825	269	3196
21G...F795	800	795	243	2961	21G...E900	950	900	320	2372
21G...F960	900	960	364	2699	21G...E980	1000	980	310	2744

(1) Select watts loss based on catalog number.

(2) For MCC Power Bus Options, add the following watts:

1250A Power Bus = 188 Watts, 2000A Power Bus = 261 Watts, 3200A Power Bus = 421 Watts

Derating Guidelines

If a catalog number is not shown, that drive can be operated without derating as long as the limits specified on pages 7 and 8 are followed.

Ambient Temperature/Load and Altitude/Load - 400V AC (Frames 1...7)

Catalog Number (see pg. 15)	400V AC Power Rating						Derating for IP20 NEMA/UL Type Open (Frames 1...5) and IP00 NEMA/UL Type Open (Frames 6 and 7)	
	Light Duty		Normal Duty		Heavy Duty		Ambient Temperature/Load	Altitude/Load
	kW	Cont. Amps	kW	Cont. Amps	kW	Cont. Amps		
20x...C8P7 (Frame 1)	—	—	4.0	8.7	2.2	5.0		
20x...C011 (Frame 1)	—	—	5.5	11.5	4.0	8.7		
20x...C015 (Frame 1)	—	—	7.5	15.4	5.5	11.5		
20x...C015 (Frame 2)	—	—	7.5	15.4	5.5	11.5		

Catalog Number (see pg. 15)	400V AC Power Rating						Derating for IP20 NEMA/UL Type Open (Frames 1...5) and IP00 NEMA/UL Type Open (Frames 6 and 7)				
	Light Duty		Normal Duty		Heavy Duty		Ambient Temperature/Load		Altitude/Load		
	kW	Cont. Amps	kW	Cont. Amps	kW	Cont. Amps	2 kHz	4 kHz	8 kHz	12 kHz	2 kHz w/Cabinet Option (21G)
20x...C022	—	—	11	22	7.5	15.4					
20x...C030	—	—	15	30	11	22					
20x...C037	—	—	18.5	37	15	30					
20x...C043	—	—	22	43	18.5	37					
20x...C060	—	—	30	60	22	43					

Catalog Number (see pg. 15)	400V AC Power Rating						Derating for IP20 NEMA/UL Type Open (Frames 1...5) and IP00 NEMA/UL Type Open (Frames 6 and 7)			
	Light Duty		Normal Duty		Heavy Duty		Ambient Temperature/Load		Altitude/Load	
	kW	Cont. Amps	kW	Cont. Amps	kW	Cont. Amps				
20x...C072	—	—	37	72	30	60				
20x...C085	—	—	45	85	37	72				
20x...C104	—	—	55	104	45	85				
20x...C140	—	—	75	140	55	104				
20x...C170	—	—	90	170	75	140				

Catalog Number (see pg. 15)	400V AC Power Rating						Derating for IP20 NEMA/UL Type Open (Frames 1...5) and IP00 NEMA/UL Type Open (Frames 6 and 7)				
	Light Duty		Normal Duty		Heavy Duty		Ambient Temperature/Load		Altitude/Load		
	kW	Cont. Amps	kW	Cont. Amps	kW	Cont. Amps	2 kHz	4 kHz	8 kHz	12 kHz	2 kHz w/Cabinet Option (21G)
20x...C205	—	—	110	205	90	170					
20x...C260	—	—	132	260	110	205					
20x...C302	—	—	160	302	132	260					
20x...C367	—	—	200	367	160	302					
20x...C456	—	—	250	456	200	367					

Catalog Number (see pg. 15)	400V AC Power Rating						Derating for IP20 NEMA/UL Type Open (Frames 1...5) and IP00 NEMA/UL Type Open (Frames 6 and 7)				
	Light Duty		Normal Duty		Heavy Duty		Ambient Temperature/Load		Altitude/Load		
	kW	Cont. Amps	kW	Cont. Amps	kW	Cont. Amps	2 kHz	4 kHz	8 kHz	12 kHz	2 kHz w/Cabinet Option (21G)
20x...C477	—	—	270	477	200	367					

Ambient Temperature/Load and Altitude/Load - 400V AC (Frames 8...10)

Catalog Number (see pg. 15)	400V AC, Power Rating at 40 °C (Power Rating at 50 °C)						Derating for IP20 NEMA/UL Type 1 (Frames 8...10), IP00 NEMA/UL Type 0 (Frames 8...10), and IP54 NEMA/UL Type 12 (Frames 8...10)	
	Light Duty		Normal Duty		Heavy Duty		Ambient Temperature/Load	Altitude/Load
	kW	Cont. Amps	kW	Cont. Amps	kW	Cont. Amps		
2xG...C460	315 (200)	540 (421)	250 (186)	460 (359)	200 (160)	385 (300)		
2xG...C540	315 (250)	585 (456)	315 (224)	540 (421)	250 (186)	456 (356)		
2xG...C567	355 (250)	612 (477)	315 (250)	567 (442)	250 (200)	472 (368)		
2xG...C650	400 (315)	750 (585)	355 (300)	650 (507)	315 (224)	540 (421)		
2xG...C750	450 (315)	796 (621)	400 (315)	750 (585)	315 (250)	585 (456)		

Catalog Number (see pg. 15)	400V AC, Power Rating at 40 °C (Power Rating at 50 °C)						Derating for IP20 NEMA/UL Type 1 (Frames 8...10), IP00 NEMA/UL Type 0 (Frames 8...10), and IP54 NEMA/UL Type 12 (Frames 8...10)			
	Light Duty		Normal Duty		Heavy Duty		Ambient Temperature/Load		Altitude/Load	
	kW	Cont. Amps	kW	Cont. Amps	kW	Cont. Amps	— 2 kHz — 4 kHz — 8 kHz — 12 kHz	— 2 kHz w/Cabinet Option (21G) — 4 kHz w/Cabinet Option (21G)		
2xG...C770	450 (355)	832 (649)	400 (355)	770 (601)	355 (300)	642 (501)				
2xG...C910	560 (425)	1040 (811)	500 (375)	910 (710)	400 (315)	750 (585)	see 2xG...C460	see 2xG...C460		
2xG...C1K0	630 (475)	1090 (850)	560 (425)	1040 (811)	500 (355)	880 (686)	see 2xG...C540	see 2xG...C540		
2xG...C1K1	710 (500)	1175 (917)	630 (475)	1090 (850)	500 (375)	910 (710)	see 2xG...C567	see 2xG...C567		
2xG...C1K2	800 (630)	1465 (1143)	710 (500)	1175 (917)	560 (425)	1040 (811)	see 2xG...C650	see 2xG...C650		
2xG...C1K4	850 (670)	1480 (1154)	800 (630)	1465 (1143)	630 (450)	1090 (850)	see 2xG...C750	see 2xG...C750		
2xG...C1K5	900 (750)	1600 (1248)	850 (670)	1480 (1154)	710 (500)	1175 (917)	see 2xG...C770	see 2xG...C770		
2xG...C1K6	1000 (710)	1715 (1338)	900 (750)	1590 (1240)	710 (600)	1325 (1034)	see 2xG...C567	see 2xG...C567		
2xG...C2K1	1400 (1000)	2330 (1817)	1250 (950)	2150 (1677)	1000 (750)	1800 (1404)	see 2xG...C770	see 2xG...C770		

Ambient Temperature/Load and Altitude/Load - 480V AC (Frames 1...7)

Catalog Number (see pg. 15)	480V AC Power Rating						Derating for IP20 NEMA/UL Type Open (Frames 1...5) and IP00 NEMA/UL Type Open (Frames 6 and 7)	
	Light Duty		Normal Duty		Heavy Duty		Ambient Temperature/Load	Altitude/Load
	Hp	Cont. Amps	Hp	Cont. Amps	Hp	Cont. Amps	— 2 kHz - - - 4 kHz - - - 8 kHz — 12 kHz — 2 kHz w/Cabinet Option (21G) — 4 kHz w/Cabinet Option (21G)	
20x...D8P0 (Frame 1)	—	—	5.0	8.0	3.0	5.0		
20x...D011 (Frame 1)	—	—	7.5	11	5.0	8.0		
20x...D014 (Frame 1)	—	—	10	14	7.5	11		
20x...D014 (Frame 2)	—	—	10	14	7.5	11		
20x...D022	—	—	15	22	10	14		

Catalog Number (see pg. 15)	480V AC Power Rating						Derating for IP20 NEMA/UL Type Open (Frames 1...5) and IP00 NEMA/UL Type Open (Frames 6 and 7)	
	Light Duty		Normal Duty		Heavy Duty		Ambient Temperature/Load	Altitude/Load
	Hp	Cont. Amps	Hp	Cont. Amps	Hp	Cont. Amps	2 kHz (solid red), 4 kHz (dashed blue), 8 kHz (dotted orange), 12 kHz (solid black) 2 kHz w/Cabinet Option (21G) (dashed purple), 4 kHz w/Cabinet Option (21G) (dotted green)	
20x...D027	–	–	20	27	15	22		
20x...D034	–	–	25	34	20	27		
20x...D040	–	–	30	40	25	34		
20x...D052	–	–	40	52	30	40		
20x...D065	–	–	50	65	40	52		

Catalog Number (see pg. 15)	480V AC Power Rating						Derating for IP20 NEMA/UL Type Open (Frames 1...5) and IP00 NEMA/UL Type Open (Frames 6 and 7)	
	Light Duty		Normal Duty		Heavy Duty		Ambient Temperature/Load	
	Hp	Cont. Amps	Hp	Cont. Amps	Hp	Cont. Amps	Altitude/Load	
20x...D077	-	-	60	77	50	65		
20x...D096	-	-	75	96	60	77		
20x...D125	-	-	100	125	75	96		
20x...D156	-	-	125	156	100	125		
20x...D186	-	-	150	186	125	156		

Catalog Number (see pg. 15)	480V AC Power Rating						Derating for IP20 NEMA/UL Type Open (Frames 1...5) and IP00 NEMA/UL Type Open (Frames 6 and 7)	
	Light Duty		Normal Duty		Heavy Duty		Ambient Temperature/Load	Altitude/Load
	Hp	Cont. Amps	Hp	Cont. Amps	Hp	Cont. Amps	— 2 kHz - - - 4 kHz - - - 8 kHz — 12 kHz — 2 kHz w/Cabinet Option (21G) — 4 kHz w/Cabinet Option (21G)	
20x...D248	—	—	200	248	150	186		
20x...D302	—	—	250	302	200	248		
20x...D361	—	—	300	361	250	302		
20x...D415	—	—	350	415	300	361		
20x...D477	—	—	400	477	300	361		

Ambient Temperature/Load and Altitude/Load - 480V AC (Frames 8...10)

Catalog Number (see pg. 15)	400V AC Power Rating at 40 °C (Power Rating at 50 °C)						Derating for IP20 NEMA/UL Type 1 (Frames 8...10), IP00 NEMA/UL Type 0 (Frames 8...10), and IP54 NEMA/UL Type 12 (Frames 8...10)	
	Light Duty		Normal Duty		Heavy Duty		Ambient Temperature/Load	Altitude/Load
	Hp	Cont. Amps	Hp	Cont. Amps	Hp	Cont. Amps	— 2 kHz - - - 4 kHz - - - 8 kHz — 12 kHz — 2 kHz w/Cabinet Option (21G) - - - 4 kHz w/Cabinet Option (21G)	
2xG...D430	400 (300)	485 (378)	350 (250)	430 (335)	300 (250)	370 (289)		
2xG...D485	450 (350)	545 (425)	400 (300)	485 (378)	350 (250)	414 (323)		
2xG...D545	500 (400)	590 (460)	450 (350)	545 (425)	350 (300)	454 (354)		
2xG...D617	600 (450)	710 (554)	500 (400)	617 (481)	400 (300)	485 (378)		
2xG...D710	650 (500)	765 (597)	600 (450)	710 (554)	450 (350)	545 (425)		

Catalog Number (see pg. 15)	400V AC Power Rating at 40 °C (Power Rating at 50 °C)						Derating for IP20 NEMA/UL Type 1 (Frames 8...10), IP00 NEMA/UL Type 0 (Frames 8...10), and IP54 NEMA/UL Type 12 (Frames 8...10)	
	Light Duty		Normal Duty		Heavy Duty		Ambient Temperature/Load	Altitude/Load
	Hp	Cont. Amps	Hp	Cont. Amps	Hp	Cont. Amps		
2xG...D740	700 (500)	800 (624)	650 (450)	740 (577)	500 (400)	617 (481)		
2xG...D800	800 (650)	960 (749)	700 (500)	800 (624)	600 (450)	710 (554)	see 2xG...D430	see 2xG...D430
2xG...D960	900 (750)	1045 (815)	800 (650)	960 (749)	700 (500)	795 (620)	see 2xG...D485	see 2xG...D485
2xG...D1K0	1000 (850)	1135 (885)	900 (700)	1045 (815)	750 (500)	800 (624)	see 2xG...D545	see 2xG...D545
2xG...D1K2	1100 (900)	1365 (1065)	1000 (800)	1135 (885)	800 (600)	960 (749)	see 2xG...D617	see 2xG...D617
2xG...D1K3	1250 (950)	1420 (1108)	1100 (900)	1365 (1065)	900 (700)	1045 (815)	see 2xG...D710	see 2xG...D710
2xG...D1K4	1350 (1000)	1540 (1201)	1250 (950)	1420 (1108)	1000 (750)	1135 (885)	see 2xG...D740	see 2xG...D740
2xG...D1K5	1500 (1100)	1655 (1291)	1350 (1000)	1525 (1190)	1100 (900)	1270 (991)	see 2xG...D545	see 2xG...D545
2xG...D2K0	2000 (1650)	2240 (1747)	1750 (1350)	2070 (1615)	1650 (1100)	1730 (1349)	see 2xG...D740	see 2xG...D740

Ambient Temperature/Load and Altitude/Load - 600V AC (Frames 3...7)

Catalog Number (see pg. 15)	600V AC Power Rating						Derating for IP20 NEMA/UL Type Open (Frames 3...5), and IP00 NEMA/UL Type Open (Frames 6 and 7)	
	Light Duty		Normal Duty		Heavy Duty		Ambient Temperature/Load	
	Hp	Cont. Amps	Hp	Cont. Amps	Hp	Cont. Amps	Altitude/Load	
20x...E017	-	-	15	17	10	11		
20x...E022	-	-	20	22	15	17		
20x...E027	-	-	25	27	20	22		
20x...E032	-	-	30	32	25	27		
20x...E041	-	-	40	41	30	32		

Catalog Number (see pg. 15)	600V AC Power Rating						Derating for IP20 NEMA/UL Type Open (Frames 3...5), and IP00 NEMA/UL Type Open (Frames 6 and 7)	
	Light Duty		Normal Duty		Heavy Duty		Ambient Temperature/Load	Altitude/Load
	Hp	Cont. Amps	Hp	Cont. Amps	Hp	Cont. Amps	— 2 kHz — 4 kHz — 8 kHz — 12 kHz — 2 kHz w/Cabinet Option (21G) — 4 kHz w/Cabinet Option (21G)	
20x...E052	—	—	50	52	40	41		
20x...E099	—	—	100	99	75	77		
20x...E125	—	—	125	125	100	99		
20x...E144	—	—	150	144	125	125		
20x...E192	—	—	200	192	150	144		

Catalog Number (see pg. 15)	600V AC Power Rating						Derating for IP20 NEMA/UL Type Open (Frames 3...5), and IP00 NEMA/UL Type Open (Frames 6 and 7)				
	Light Duty		Normal Duty		Heavy Duty		Ambient Temperature/Load		Altitude/Load		
	Hp	Cont. Amps	Hp	Cont. Amps	Hp	Cont. Amps	2 kHz	4 kHz	8 kHz	12 kHz	2 kHz w/Cabinet Option (21G)
20x...E242	—	—	250	242	200	192					
20x...E289	—	—	300	289	250	242					

Ambient Temperature/Load and Altitude/Load - 600V AC (Frames 8...10)

Catalog Number (see pg. 15)	400V AC Power Rating at 40 °C (Power Rating at 50 °C)						Derating for IP20 NEMA/UL Type 1 (Frames 8...10), IP00 NEMA/UL Type 0 (Frames 8...10), and IP54 NEMA/UL Type 12 (Frames 8...10)	
	Light Duty		Normal Duty		Heavy Duty		Ambient Temperature/Load	Altitude/Load
	Hp	Cont. Amps	Hp	Cont. Amps	Hp	Cont. Amps	— 2 kHz - - - 4 kHz - - - 8 kHz — 12 kHz — 2 kHz w/Cabinet Option (21G) - - - 4 kHz w/Cabinet Option (21G)	
2xG...E295	350 (250)	355 (277)	300 (200)	295 (230)	250 (200)	272 (212)		
2xG...E355	400 (300)	395 (308)	350 (250)	355 (277)	300 (200)	295 (230)		
2xG...E395	450 (300)	435 (339)	400 (300)	395 (308)	350 (250)	329 (257)		
2xG...E435	500 (350)	460 (359)	450 (300)	435 (339)	350 (250)	355 (277)		
2xG...E460	500 (400)	510 (398)	500 (350)	460 (359)	400 (300)	395 (308)		

Catalog Number (see pg. 15)	400V AC Power Rating at 40 °C (Power Rating at 50 °C)						Derating for IP20 NEMA/UL Type 1 (Frames 8...10), IP00 NEMA/UL Type 0 (Frames 8...10), and IP54 NEMA/UL Type 12 (Frames 8...10)	
	Light Duty		Normal Duty		Heavy Duty		Ambient Temperature/Load	Altitude/Load
	Hp	Cont. Amps	Hp	Cont. Amps	Hp	Cont. Amps		
2xG...E510	550 (400)	545 (425)	500 (400)	510 (398)	450 (300)	425 (332)		
2xG...E595	700 (500)	690 (538)	600 (450)	595 (464)	500 (400)	510 (398)	see 2xG...E295	see 2xG...E295
2xG...E630	800 (550)	760 (593)	700 (500)	630 (491)	600 (450)	595 (464)	see 2xG...E395	see 2xG...E355
2xG...E760	900 (650)	835 (651)	800 (550)	760 (593)	700 (500)	630 (491)	see 2xG...E395	see 2xG...E395
2xG...E825	950 (700)	900 (702)	900 (600)	825 (644)	750 (550)	700 (546)	see 2xG...E435	see 2xG...E435
2xG...E900	1000 (750)	980 (764)	950 (700)	900 (702)	800 (600)	760 (593)	see 2xG...E460	see 2xG...E460
2xG...E980	1100 (800)	1045 (815)	1000 (750)	980 (764)	900 (625)	815 (636)	see 2xG...E510	see 2xG...E510
2xG...E1K1	1200 (950)	1220 (952)	1100 (850)	1110 (866)	1000 (700)	920 (718)	see 2xG...E395	see 2xG...E395
2xG...E1K4	1500 (1100)	1530 (1193)	1400 (1000)	1430 (1115)	1250 (900)	1190 (928)	see 2xG...E510	see 2xG...E510

Ambient Temperature/Load and Altitude/Load - 690V AC (Frames 6 and 7)

Catalog Number (see pg. 15)	690V AC Power Rating						Derating for IP00 NEMA/UL Type Open (Frames 6 and 7)	
	Light Duty		Normal Duty		Heavy Duty		Ambient Temperature/Load	Altitude/Load
	kW	Cont. Amps	kW	Cont. Amps	kW	Cont. Amps		
2xG...F030	—	—	22	30	18.5	23		
2xG...F034	—	—	30	34	22	30		
2xG...F046	—	—	37	46	30	34		
2xG...F050	—	—	45	50	37	46		
2xG...F061	—	—	55	61	45	50		

Catalog Number (see pg. 15)	690V AC Power Rating						Derating for IP00 NEMA/UL Type Open (Frames 6 and 7)	
	Light Duty		Normal Duty		Heavy Duty		Ambient Temperature/Load	Altitude/Load
	kW	Cont. Amps	kW	Cont. Amps	kW	Cont. Amps	2 kHz (red), 4 kHz (blue), 8 kHz (orange), 12 kHz (black) 2 kHz w/Cabinet Option (21G) (purple), 4 kHz w/Cabinet Option (21G) (green)	
2xG...F082	—	—	75	82	55	61		
2xG...F098	—	—	90	98	75	82		
2xG...F119	—	—	110	119	90	98		
2xG...F142	—	—	132	142	110	119		
2xG...F171	—	—	160	171	132	142		

Catalog Number (see pg. 15)	690V AC Power Rating						Derating for IP00 NEMA/UL Type Open (Frames 6 and 7)	
	Light Duty		Normal Duty		Heavy Duty		Ambient Temperature/Load	Altitude/Load
	kW	Cont. Amps	kW	Cont. Amps	kW	Cont. Amps		
2xG...F212	—	—	200	212	160	171		
2xG...F263	—	—	250	263	200	212		

Ambient Temperature/Load and Altitude/Load - 690V AC (Frames 8...10)

Catalog Number (see pg. 15)	400V AC Power Rating at 40 °C (Power Rating at 50 °C)						Derating for IP20 NEMA/UL Type 1 (Frames 8...10), IP00 NEMA/UL Type 0 (Frames 8...10), and IP54 NEMA/UL Type 12 (Frames 8...10)			
	Light Duty		Normal Duty		Heavy Duty		Ambient Temperature/Load		Altitude/Load	
	kW	Cont. Amps	kW	Cont. Amps	kW	Cont. Amps				
2xG...F265	315 (250)	330 (257)	250 (200)	265 (207)	200 (160)	215 (168)				
2xG...F330	355 (250)	370 (289)	315 (224)	330 (257)	250 (200)	265 (207)				
2xG...F370	400 (315)	410 (320)	355 (250)	370 (289)	300 (224)	308 (240)				
2xG...F415	450 (355)	460 (359)	400 (315)	415 (324)	355 (250)	370 (289)				
2xG...F460	500 (375)	500 (390)	450 (350)	460 (359)	375 (300)	375 (293)				

Catalog Number (see pg. 15)	400V AC Power Rating at 40 °C (Power Rating at 50 °C)						Derating for IP20 NEMA/UL Type 1 (Frames 8...10), IP00 NEMA/UL Type 0 (Frames 8...10), and IP54 NEMA/UL Type 12 (Frames 8...10)	
	Light Duty		Normal Duty		Heavy Duty		Ambient Temperature/Load	Altitude/Load
	kW	Cont. Amps	kW	Cont. Amps	kW	Cont. Amps		
2xG...F500	530 (400)	530 (413)	500 (400)	500 (390)	400 (315)	413 (322)		
2xG...F590	630 (500)	650 (507)	560 (450)	590 (460)	450 (355)	460 (359)	see 2xG...F265	see 2xG...F265
2xG...F650	710 (530)	710 (554)	630 (500)	650 (507)	500 (375)	500 (390)	see 2xG...F330	see 2xG...F330
2xG...F710	800 (560)	790 (616)	710 (530)	710 (554)	560 (450)	590 (460)	see 2xG...F370	see 2xG...F370
2xG...F765	850 (630)	860 (671)	750 (600)	765 (597)	630 (500)	650 (507)	see 2xG...F415	see 2xG...F415
2xG...F795	900 (710)	960 (749)	800 (630)	795 (620)	710 (600)	750 (585)	see 2xG...F460	see 2xG...F460
2xG...F960	1000 (800)	1020 (796)	900 (750)	960 (749)	800 (600)	795 (620)	see 2xG...F500	see 2xG...F500
2xG...F1K0	1100 (900)	1150 (897)	1000 (750)	1040 (811)	900 (670)	865 (675)	see 2xG...F370	see 2xG...F370
2xG...F1K4	1500 (1120)	1485 (1158)	1400 (1000)	1400 (1092)	1120 (900)	1160 (905)	see 2xG...F500	see 2xG...F500

Minimum Dynamic Brake Resistance

Table shows the minimum dynamic brake resistance when using the internal dynamic braking transistor.

Brake Resistance for 400/480V Drives

Frame	480V				400V			
	ND Hp	Catalog Code	Minimum Resistance	Maximum DB Current	ND kW	Catalog Code	Minimum Resistance	Maximum DB Current
1	1.0	2P1	79.0	10	0.75	C2P1	79.0	10
	2.0	D3P4	79.0	10	1.5	C3P5	79.0	10
	3.0	D5P0	79.0	10	2.2	C5P0	79.0	10
	5.0	D8P0	52.7	15	4	C8P7	52.7	15
	7.5	D011	31.6	25	5.5	C011	31.6	25
	10	D014	31.6	25	7.5	C015	31.6	25
2	1.0	D2P1	31.6	25	0.75	C2P1	31.6	25
	2.0	D3P4	31.6	25	1.5	C3P5	31.6	25
	3.0	D5P0	31.6	25	2.2	C5P0	31.6	25
	5.0	D8P0	31.6	25	4	C8P0	31.6	25
	7.5	D011	31.6	25	5.5	C011	31.6	25
	10	D014	31.6	25	7.5	C015	31.6	25
	15	D022	22.6	34.9	11	C022	22.6	34.9
3	20	D027	31.6	25	15	C030	31.6	25
	25	D034	31.6	25	18.5	C037	31.6	25
	30	D040	16.6	47.6	22	C043	16.6	47.6
4	40	D052	15.8	50	30	C060	15.8	50
	50	D065	15.8	50	37	C072	15.8	50
5	50 ⁽¹⁾	D065 ⁽¹⁾	7.9	100	37 ⁽¹⁾	C075 ⁽¹⁾	7.9	100
	60	D077	7.9	100	45	C085	7.9	100
	75	D096	7.9	100	55	C104	7.9	100
6	75 ⁽¹⁾	D096 ⁽¹⁾	3.3	239.4	55 ⁽¹⁾	C104 ⁽¹⁾	3.3	239.4
	100	D125	3.3	239.4	75	C140	3.3	239.4
	125	D156	3.3	239.4	90	C170	3.3	239.4
	150	D186	3.3	239.4	110	C205	3.3	239.4
	200	D248	3.3	239.4	132	C260	3.3	239.4
7	200 ⁽¹⁾	D248 ⁽¹⁾	2.4	329	132 ⁽¹⁾	C260 ⁽¹⁾	2.4	329
	250	D302	2.4	329	160	C302	2.4	329
	300	D361	2.4	329	200	C367	2.4	329
	350	D415	1.65	478.8	250	C456	1.65	478.8
	400	D477	1.65	478.8	270	C477	1.65	147.8

(1) IP54, NEMA/UL Type 12 (enclosure code G).

Brake Resistance for 600V Drives (Frames 3...5)

Frame	600V			
	ND Hp	Catalog Code	Minimum Resistance	Maximum DB Current
3	1.0	E1P7	92	11
	2.0	E2P7	92	11
	3.0	E3P9	92	11
	5.0	E6P1	32	30
	7.5	E9P0	32	30
	10	E011	32	30
	15	E017	32	30
	20	E022	32	30
4	25	E027	32	30
	30	E032	32	30
5	40	E041	13.5	71
	50	E052	13.5	71

Brake Resistance for 600/690V Drives (Frames 6 and 7)

Frame	600V				690V			
	ND Hp	Catalog Code	Minimum Resistance	Maximum DB Current	ND kW	Catalog Code	Minimum Resistance	Maximum DB Current
6	10	E012	14.4	76.4	7.5	F012	14.4	76.4
	15	E018	14.4	76.4	11	F015	14.4	76.4
	20	E023	14.4	76.4	15	F020	14.4	76.4
	20	E024	14.4	76.4	18.5	F023	14.4	76.4
	25	E028	14.4	76.4	22	F030	14.4	76.4
	30	E033	14.4	76.4	30	F034	14.4	76.4
	40	E042	14.4	76.4	37	F046	14.4	76.4
	50	E053	14.4	76.4	45	F050	14.4	76.4
	60	E063	5.5	200	55	F061	5.5	200
	75	E077	5.5	200	75	F082	5.5	200
	100	E099	5.5	200	90	F098	5.5	200
	125	E125	5.5	200	110	F119	5.5	200
	150	E144	5.5	200	132	F142	5.5	200
	7	200	E192	3.8	289	160	F171	3.8
250		E242	3.8	289	200	F212	3.8	289
300		E289	3.2	344	250	F263	3.2	344

Fuse and Circuit Breaker Ratings

The tables on the following pages provide recommended AC line input fuse and circuit breaker information. See Fusing and Circuit Breakers on the next page for UL and IEC requirements. Sizes listed are the recommended sizes based on 40 °C (104 °F) and the U.S. NEC. Other country, state, or local codes can require different ratings. DC link fuse recommendations for DC input drives are also provided. In addition, frame 8 and larger drives include AC line fuses (with blown fuse indicators) to provide drive short circuit protection.

Input Device Requirements

Frames	Enclosure Catalog Code	Enclosure Type	Installation Type	UL Certification Required	UL Certification Not Required
1	R	IP20 NEMA/UL Open Type	Installed in a ventilated or non-ventilated cabinet.	All devices listed on pages 42 and 46 are acceptable. When installed in a ventilated cabinet, time delay fuses, circuit breakers, and 140M Combination Motor Controllers must meet or exceed the listed minimum enclosure volume on pages 42 and 46 to be acceptable.	All devices listed on pages 42 through 55 are acceptable.
			Installed outside of cabinet by using NEMA Type 1 kit or in a ventilated cabinet.	Only non-time delay fuses listed on pages 42 and 46 , excluding maximum value, are acceptable.	
2...5	N	IP20 NEMA/UL Open Type	Installed in a ventilated or non-ventilated cabinet. Heat sink is inside or outside of cabinet.	All devices listed on pages 42 , 46 , and 50 are acceptable.	
	F	Flange		When installed in a ventilated cabinet, time delay fuses, circuit breakers, and 140M Combination Motor Controllers must meet or exceed the listed minimum enclosure volume on pages 42 , 46 , and 50 to be acceptable.	
	N	IP20 NEMA/UL Open Type	Installed outside of cabinet by using NEMA Type 1 kit or in a ventilated cabinet.	400V AC/540V DC or 480V AC/650V DC drives: Only non-time delay fuses listed on pages 42 and 46 , excluding maximum value, are acceptable.	
	F	Flange		600V AC/810V DC drives: Only non-time delay fuses listed on page 50 are acceptable, with maximum value of 40A (frame 3), 60A (frame 4), and 100A (frame 5).	
	G	IP54 NEMA/UL Type 12	Installed inside or outside of any cabinet.	All devices listed on pages 42 , 46 , and 50 are acceptable.	
6 and 7	N	IP00 NEMA/UL Open Type	Installed in any cabinet. Heat sink is inside or outside of cabinet.	400V AC/540V DC or 480V AC/650V DC drives: All devices listed on pages 42 and 46 are acceptable.	
			Installed outside of cabinet by using NEMA Type 1 kit.	600V AC/810V DC drives: Only time delay and non-time delay fuses listed on page 50 are acceptable.	
	G	IP54 NEMA/UL Type 12	Installed inside or outside of any cabinet.	All devices listed on pages 42 , 46 , and 50 are acceptable.	
8...10	B, L, P, W	IP20 NEMA/UL Type 1	Installed inside of any cabinet.	All devices listed on pages 44 , 48 , and 52 are acceptable.	
	J, K, Y	IP54 NEMA 12	Installed inside or outside of any cabinet.	All devices listed on pages 44 , 48 , and 52 are acceptable.	

IMPORTANT For maximum protection of the drive and its internal components, Rockwell Automation prefers the use of UL-listed, fast-acting semiconductor fuses to other methods of circuit protection. This reduces the risk of drive damage from power quality events and improves machine and process utilization, thus maximizing productivity.

Fusing

The recommended fuse types are listed below. If available current ratings do not match those listed in the tables provided, choose the next higher fuse rating.

- IEC – BS88 (British Standard) Parts 1 & 2, EN60269-1, Parts 1 & 2⁽¹⁾, type gG or equivalent must be used.
- UL – UL Class CC, T, RK1, J, or L must be used.

Circuit Breakers

The “non-fuse” listings in the following tables include inverse time circuit breakers, instantaneous trip circuit breakers (motor circuit protectors) and 140M self-protected combination motor controllers. If one of these is chosen as the desired protection method, the following requirements apply:

- IEC – Both types of circuit breakers and 140M self-protected combination motor controllers are acceptable for IEC installations.
- UL - Only inverse time circuit breakers and the specified 140M self-protected combination motor controllers are acceptable for UL installations.

(1) Typical designations include, but is not limited to the following; Parts 1 & 2: AC, AD, BC, BD, CD, DD, ED, EFS, EF, FF, FG, GF, GG, GH.

400 Volt AC and 540 Volt DC Input Protection Devices - Wall Mount Frames 1...7

Applied Rating (1)	Frame (2)	Drive Sized For Normal Duty		Drive Sized For Heavy Duty		Input Quantities		AC Input Protection Devices						DC Input Protection (14)				
		Catalog Number (x = F or G)	Output Overload Amps 1 min	3 sec	Catalog Number (x = F or G)	Output Overload Amps 1 min	3 sec	Continuous AC Input kVA	Dual Element Time Delay Fuse Min (4)	Max (5)	Non-Time Delay Fuse Min (4)	Max (5)	Circuit Breaker Max Size (6)	Circuit Breaker, Dual Element Time Delay Fuse Min Enclosure Volume (in.³) (7)	Motor Protector Circuit (8)	140M Type E Combination Motor Controller with Adjustable Current Range (9) (10)	Continuous DC Input	Non-Time Delay Fuse
400 Volt AC Input																		
0.75 kW	1	2.1	2.3	3.2	2.3	3.2	1.2	2	3	2	3	15	3840	3	M-xxx-B25 (11)	7269	2.1	JKS-6
1.5 kW	1	3.5	3.9	5.3	3.9	5.3	1.9	6	6	6	6	15	3840	7	M-xxx-B40 (11)	7269	3.7	JKS-8
2.2 kW	1	5	5.5	7.5	5.5	7.5	3.1	6	6	6	6	20	3840	7	M-xxx-B63 (11)	7269	5.3	JKS-10
4.0 kW	1	8.7	9.6	13.1	9.6	13.1	5.4	10	15	10	15	30	3840	15	M-xxx-C10 (11)	7269	9.3	HSJ15
5.5 kW	1	11.5	12.7	17.3	13.1	17.3	7.4	15	20	15	20	45	3840	15	M-xxx-C16 (11)	7269	12.6	HSJ20
7.5 kW	1	15.4	16.9	23.1	17.3	23.1	10.1	20	25	20	25	60	3840	20	M-xxx-C20 (11)	7269	17.0	HSJ25
0.75 kW	2	2.1	3.1	3.7	3.1	3.7	1.2	3	6	3	8	15	3840	3	M-xxx-B25 (11)	9086	2.1	JKS-6
1.5 kW	2	3.5	5.2	6.3	5.2	6.3	1.9	6	7	6	12	15	3840	7	M-xxx-B40 (11)	9086	3.7	JKS-8
2.2 kW	2	5	7.5	9.0	7.5	9.0	3.1	6	10	6	20	20	3840	7	M-xxx-B63 (11)	9086	5.3	JKS-10
4.0 kW	2	8.7	13.0	15.6	13.0	15.6	5.4	10	17.5	10	30	30	3840	15	M-xxx-C10 (11)	9086	9.3	HSJ15
5.5 kW	2	11.5	17.2	20.7	17.2	20.7	7.4	15	25	15	45	45	3840	15	M-xxx-C16 (11)	9086	12.6	HSJ20
7.5 kW	2	15.4	16.9	23.1	24.2	33.0	10.1	20	30	20	60	60	3840	20	M-xxx-C20 (11)	9086	17.0	HSJ25
11 kW	2	22	24.2	33.0	33.0	45.0	14.6	30	45	30	80	80	3840	30	M-xxx-C25 (12)	9086	24.6	HSJ40
15 kW	3	30	33.0	45.0	45.0	55.5	19.9	40	60	40	120	100	4800	50	M-F8E-C32	9086	33.6	HSJ50
18.5 kW	3	37	40.7	55.5	55.5	66.6	24.5	45	80	45	125	110	4800	50	M-F8E-C45	9086	41.4	HSJ70
22 kW	3	43	47.3	64.5	66.0	90.0	28.5	55	90	55	150	120	4800	60			48.1	HSJ90
30 kW	4	60	66.0	90.0	90.0	108.0	39.8	75	125	75	225	180	4800	100			67.1	HSJ100
37 kW	4	72	79.2	108.0	108.0	129.6	48.9	90	150	90	275	200	4800	100			82.4	HSJ125
45 kW	5	85	93.5	127.5	127.5	156.0	57.7	83.3	110	110	325	250	7200	150			97.3	HSJ150
55 kW	5	104	114.4	156.0	156.0	210.0	71.3	102.9	130	130	400	300	7200	150			120.2	HSJ175
75 kW	6	140	154.0	210.0	210.0	255.0	95.0	137.2	175	175	550	400		250			160.3	HSJ250
90 kW	6	170	187.0	255.0	255.0	307.5	115.4	166.5	225	225	600	500		250			194.6	HSJ350
110 kW	6	205	225.5	307.5	307.5	390.0	139.1	200.8	275	275	600	600		400			234.7	HSJ350
132 kW	6	260	286.0	390.0	390.0	468.0	176.5	254.7	325	325	750	700		400			297.7	HSJ400
160 kW	7	302	332.2	453.0	453.0	550.5	205.0	295.9	400	400	900	900		600			345.7	Busman 170M6608
200 kW	7	367	403.7	550.5	550.5	684.0	249.1	359.5	475	800	1000	1100		600			420.2	Busman 170M6612
250 kW	7	456	501.6	684.0			309.5	446.7	600	1000	1800	1300		600			522.0	Busman 170M6613
270 kW	7	477	524	715.5			323.8	467.3	600	1000	1400	1400		600			546.0	Busman 170M6613

See page 43 for notes.

- (1) "Applied Rating" refers to the motor that is connected to the drive. For example, a "C02Z" drive can be used in Normal Duty mode on an 11 kW motor, or in Heavy Duty mode on a 7.5 kW motor. A "C01S" drive can be used in Heavy Duty mode on a 5.5 kW motor with the same ratings as a "C01T." The drive can be programmed for either mode. Wiring and fuses can be sized based on the programmed mode. For any given drive catalog number, Normal Duty mode provides higher continuous current but smaller overload current with respect to Heavy Duty mode. See parameter 306 [Duty Rating].
- (2) Enclosure codes F, N, and R only. See Frame/Rating Cross-Reference in PowerFlex 750-Series AC Drives Technical Data, publication [750-TD001](#), for frame sizes of other enclosure types.
- (3) This drive is the next larger frame size.
- (4) Minimum protection device size is the lowest rated device that supplies maximum protection without nuisance tripping.
- (5) Maximum protection device size is the highest rated device that supplies drive protection. For US NEC, minimum size is 125% of motor FLA. Ratings shown are maximum.
- (6) Circuit Breaker - inverse time breaker. For US NEC, minimum size is 125% of motor FLA. Ratings shown are maximum.
- (7) When using a circuit breaker or time-delay fuse with a drive installed in a ventilated enclosure, the enclosure volume must be greater than or equal to the minimum volume specified in this column. Application-specific thermal considerations can require a larger enclosure.
- (8) Recommended Motor circuit protector - Instantaneous trip circuit breaker. The trip setting must be set to the input current of the drive and must be sized for the continuous current of the system.
- (9) Bulletin 140M with adjustable current range must have the current trip set to the minimum range so that the device does not trip.
- (10) Manual Self-Protected (Type E) Combination Motor Controller, UL listed for 480Y/277V and 600Y/347V AC Input. Not UL listed for use on 480V or 600V Delta/Delta, corner ground, or high-resistance ground systems.
- (11) Bulletin 140M must be frame C (C2E), frame D (D8F), or frame F (F8E).
- (12) Bulletin 140M must be frame D (D8F) or frame F (F8E).
- (13) When using a Manual Self-Protected (Type E) Combination Motor Controller, the drive must be installed in a ventilated or non-ventilated enclosure with the minimum volume specified in this column. Application specific thermal considerations can require a larger enclosure.
- (14) See Fuse Certification and Test Data in PowerFlex AC Drives in Common Bus Configurations Application Guidelines, publication [DRIVES-A1002](#), for fuse self-certification and test data for Bussmann 170M and JKS fuses recommended for the DC bus fusing.

400 Volt AC and 540 Volt DC Input Protection Devices - Floor Mount Protection Devices 8...10

Applied Rating ⁽¹⁾	Frame	Cont. Output Amps	Duty	Catalog Number	Output Overload Amps		AC Input Integral Semiconductor Fuse Size (170M) ⁽²⁾	DC Bay to Bay Integral Semiconductor Fuse Size (170M)	AC Input Protection Devices Recommended for Branch Circuit Protection (Does not apply to 21G Drives with Options)						DC Input Integral Semiconductor Fuse Size (170M) ⁽⁸⁾			
					1 min	3 sec			Continuous AC Input		Dual Element Time Delay Fuse		Non-Time Delay Fuse			Circuit Breaker Max Size ⁽⁶⁾	Motor Circuit Protector ⁽⁷⁾	
									Amps	Amps	1/Phase Min ⁽⁴⁾	2/Phase Min ⁽⁴⁾	1/Phase Min ⁽⁴⁾	2/Phase Min ⁽⁴⁾				Max ⁽⁵⁾
400V AC Input																		
200 kW	8	385	Heavy	206...C460	578	693	380	1100	—	500	—	850	500	—	1100	1100	500	1600
250 kW	8	460	Normal	206...C460	506	693	455	1100	—	600	—	1000	600	—	1300	1300	600	1600
		436	Heavy	206...C540	684	821	450	1100	—	600	—	1000	600	—	1300	1300	600	1600
		472	Heavy	206...C567	708	851	466	1100	—	600	—	1000	600	—	1400	1400	600	1600
315 kW	8	540	Light	206...C460	594	—	534	1100	—	700	350	1200	700	350	1600	1600	700	1600
		540	Normal	206...C540	594	821	533	1100	—	700	350	1200	700	350	1600	1600	700	1600
		540	Heavy	206...C650	810	975	533	1100	—	700	—	1200	700	—	1600	1600	700	1600
315 kW	8	585	Light	206...C540	644	—	578	1100	—	750	375	1300	750	375	1700	1700	800	1600
		567	Normal	206...C567	624	851	560	1100	—	750	375	1200	750	375	1700	1700	700	1600
		585	Heavy	206...C750	878	1125	577	1100	—	750	375	1300	750	375	1700	1700	800	1600
355 kW	8	612	Light	206...C567	673	—	604	1100	—	800	400	1300	800	400	1800	1800	800	1600
		650	Normal	206...C650	715	975	640	1100	—	850	425	1400	850	425	1900	1900	800	1600
		642	Heavy	206...C770	963	1155	634	1100	—	800	400	1400	800	400	1900	1900	800	1600
400 kW	8	750	Light	206...C650	825	—	739	1100	—	1000	500	1600	1000	500	2200	2200	1000	1600
		750	Normal	206...C750	825	1125	739	1100	—	1000	500	1600	1000	500	2200	2200	1000	1600
		770	Normal	206...C770	847	1155	758	1100	—	1000	500	1700	1000	500	2300	2300	1000	1600
450 kW	8	796	Light	206...C750	876	—	784	1100	—	1000	500	1700	1000	500	2300	2300	1000	1600
		832	Light	206...C770	915	—	819	1100	—	1100	550	1800	1100	550	2400	2400	1200	1600
400 kW	9	750	Heavy	206...C910	1125	1365	739	1100	1400 ⁽³⁾	900	450	1700	900	450	2200	2200	900	1600 ⁽³⁾
500 kW	9	880	Heavy	206...C1K0	1320	1584	867	1100	1400 ⁽³⁾	1100	550	2000	1100	550	2600	2600	1100	1600 ⁽³⁾
		910	Heavy	206...C1K1	1365	1638	896	1100	1400 ⁽³⁾	1100	550	2000	1100	550	2700	2700	1100	1600 ⁽³⁾
560 kW	9	910	Normal	206...C910	1001	1365	896	1100	1400 ⁽³⁾	1100	550	2000	1100	550	2700	2700	1100	1600 ⁽³⁾
		1040	Light	206...C910	1144	—	1024	1100	1400 ⁽³⁾	1300	650	2300	1300	650	3100	3100	1300	1600 ⁽³⁾
		1040	Normal	206...C1K0	1144	1584	1024	1100	1400 ⁽³⁾	1300	650	2300	1300	650	3100	3100	1300	1600 ⁽³⁾
		1040	Heavy	206...C1K2	1560	1872	1024	1100	1400 ⁽³⁾	1300	650	2300	1300	650	3100	3100	1300	1600 ⁽³⁾
630 kW	9	1090	Light	206...C1K0	1199	—	1073	1100	1400 ⁽³⁾	1350	675	2400	1350	675	3200	3200	1350	1600 ⁽³⁾
		1090	Normal	206...C1K1	1199	1638	1073	1100	1400 ⁽³⁾	1350	675	2400	1350	675	3200	3200	1350	1600 ⁽³⁾
		1090	Heavy	206...C1K4	1635	2198	1073	1100	1400 ⁽³⁾	1350	675	2400	1350	675	3200	3200	1350	1600 ⁽³⁾

continued on page 45

480 Volt AC and 650 Volt DC Input Protection Devices - Wall Mount Frames 1...7

Applied Rating (1)	Frame (2)	Drive Sized For Normal Duty				Drive Sized For Heavy Duty				Input Quantities		AC Input Protection Devices						140M Type E Combination Motor Controller with Adjustable Current Range (9) (10)	Motor Protector Circuit (8)	DC Input Protection (14)	
		Catalog Number		Output Overload Amps		Catalog Number		Output Overload Amps		Continuous AC Input	Dual Element Time Delay Fuse	Circuit Breaker	Circuit Breaker, Time Delay Fuse	Circuit Breaker, Time Delay Fuse	Min Enclosure Volume (in.³) (7)	Max Size (6)	Non-Time Delay Fuse				Min Enclosure Volume (in.³) (13)
		(x = F or G)	(x = F or G)	1 min	3 sec	(x = F or G)	(x = F or G)	1 min	3 sec												
480 Volt AC Input																					
1.0 Hp	1	2.1	20x...D2P1	2.3	3.2	20x...D2P1	2.3	3.2	1.3	1.6	2	3	2	3	15	3840	3	M-xxx-B25 (11)	7269	JKS-6	
2.0 Hp	1	3.4	20x...D3P4	3.7	5.1	20x...D3P4	3.7	5.1	2.2	2.6	6	6	6	6	15	3840	7	M-xxx-B40 (11)	7269	JKS-6	
3.0 Hp	1	5	20x...D5P0	5.5	7.5	20x...D5P0	5.5	7.5	3.2	3.9	6	6	6	6	20	3840	7	M-xxx-B63 (11)	7269	JKS-10	
5.0 Hp	1	8	20x...D8P0	8.8	12.0	20x...D8P0	8.8	12.0	5.7	6.9	10	15	10	15	30	3840	15	M-xxx-C10 (11)	7269	HSJ15	
7.5 Hp	1	11	20x...D011	12.1	16.5	20x...D011	12.1	16.5	7.9	9.5	15	20	15	20	40	3840	15	M-xxx-C16 (11)	7269	HSJ20	
10 Hp	1	14	20x...D014	15.4	21.0	20x...D022 (3)	16.5	21.0	10.4	12.5	20	25	20	25	50	3840	20	M-xxx-C16 (11)	7269	HSJ30	
1.0 Hp	2	2.1	20x...D2P1	3.1	3.7	20x...D2P1	3.1	3.7	1.3	1.6	2	6	2	8	15	3840	3	M-xxx-B25 (11)	9086	JKS-6	
2.0 Hp	2	3.4	20x...D3P4	5.1	6.1	20x...D3P4	5.1	6.1	2.2	2.6	4	7	4	12	15	3840	7	M-xxx-B40 (11)	9086	JKS-6	
3.0 Hp	2	5	20x...D5P0	7.5	9.0	20x...D5P0	7.5	9.0	3.2	3.9	6	10	6	20	20	3840	7	M-xxx-B63 (11)	9086	JKS-10	
5.0 Hp	2	8	20x...D8P0	12.0	14.4	20x...D8P0	12.0	14.4	5.7	6.9	10	17.5	10	30	30	3840	15	M-xxx-C10 (11)	9086	HSJ15	
7.5 Hp	2	11	20x...D011	16.5	19.8	20x...D011	16.5	19.8	7.9	9.5	12	20	12	40	40	3840	15	M-xxx-C16 (11)	9086	HSJ20	
10 Hp	2	14	20x...D014	15.4	21.0	20x...D022 (3)	24.2	33.0	10.4	12.5	20	30	20	55	50	3840	20	M-xxx-C16 (11)	9086	HSJ30	
15 Hp	2	22	20x...D022	24.2	33.0	20x...D027 (3)	33.0	40.5	16.6	19.9	30	50	30	80	80	3840	30	M-xxx-C25 (12)	9086	HSJ40	
20 Hp	3	27	20x...D027	29.7	40.5	20x...D034	40.5	51.0	20.6	24.8	35	60	35	100	100	4800	50	M-F8E-C32	9086	HSJ50	
25 Hp	3	34	20x...D034	37.4	51.0	20x...D040	51.0	61.2	25.9	31.2	45	75	45	125	100	4800	50	M-F8E-C45	9086	HSJ60	
30 Hp	3	40	20x...D040	44.0	60.0	20x...D052 (3)	60.0	78.0	30.5	36.7	50	90	50	150	120	4800	50	M-F8E-C45	9086	HSJ80	
40 Hp	4	52	20x...D052	57.2	78.0	20x...D065	78.0	97.5	39.7	47.7	65	110	65	200	150	4800	70	M-F8E-C45	9086	HSJ90	
50 Hp	4	65	20x...D065	71.5	97.5	20x...D077 (3)	97.5	117.0	49.6	59.6	90	125	90	250	175	4800	100	M-F8E-C45	9086	HSJ100	
60 Hp	5	77	20x...D077	84.7	115.5	20x...D096	115.5	144.0	60.1	72.3	100	170	100	300	225	7200	100	M-F8E-C45	9086	HSJ150	
75 Hp	5	96	20x...D096	105.6	144.0	20x...D125 (3)	144.0	187.5	74.9	90.1	125	200	125	375	275	7200	125	M-F8E-C45	9086	HSJ175	
100 Hp	6	125	20x...D125	137.5	187.5	20x...D156	187.5	234.0	97.6	117.4	175	275	175	500	375	7200	250	M-F8E-C45	9086	HSJ200	
125 Hp	6	156	20x...D156	171.6	234.0	20x...D186	234.0	280.8	121.8	146.5	200	350	200	600	450	7200	250	M-F8E-C45	9086	HSJ300	
150 Hp	6	186	20x...D186	204.6	279.0	20x...D248	279.0	372.0	145.2	174.6	250	400	250	600	550	7200	250	M-F8E-C45	9086	HSJ400	
200 Hp	6	248	20x...D248	272.8	372.0	20x...D302 (3)	372.0	453.0	193.6	232.8	325	550	325	700	700	7200	400	M-F8E-C45	9086	HSJ400	
250 Hp	7	302	20x...D302	332.2	453.0	20x...D361	453.0	543.6	235.7	283.5	400	675	400	900	900	7200	600	M-F8E-C45	9086	HSJ400	
300 Hp	7	361	20x...D361	397.1	541.5	20x...D415	541.5	649.8	281.8	338.9	475	800	475	1000	1000	7200	600	M-F8E-C45	9086	HSJ400	
350 Hp	7	415	20x...D415	456.5	622.5				323.9	389.6	525	900	525	1200	1200	7200	600	M-F8E-C45	9086	HSJ400	
400 Hp	7	477	20x...D477	524.7	715.5				372.3	447.8	600	1000	600	1400	1400	7200	600	M-F8E-C45	9086	HSJ400	

See page 47 for notes.

- (1) "Applied Rating" refers to the motor that is connected to the drive. For example, a "D022" drive can be used in Normal Duty mode on a 15 Hp motor, or in Heavy Duty mode on a 10 Hp motor. A "D014" drive can be used in Heavy Duty mode on a 7.5 Hp motor with the same ratings as a "D011." The drive can be programmed for either mode. Wiring and fuses can be sized based on the programmed mode. For any given drive catalog number, Normal Duty mode provides higher continuous current but smaller overload current with respect to Heavy Duty mode. See parameter 306 [Duty Rating].
- (2) Enclosure codes F, N, and R only. See Frame/Rating Cross-reference in PowerFlex 750-Series AC Drives Technical Data, publication [750-TD001](#), for frame sizes of other enclosure types.
- (3) This drive is the next larger frame size.
- (4) Minimum protection device size is the lowest rated device that supplies maximum protection without nuisance tripping.
- (5) Maximum protection device size is the highest rated device that supplies drive protection. For US NEC, minimum size is 125% of motor FLA. Ratings shown are maximum.
- (6) Circuit Breaker - inverse time breaker. For US NEC, minimum size is 125% of motor FLA. Ratings shown are maximum.
- (7) When using a circuit breaker or time-delay fuse with a drive installed in a ventilated enclosure, the enclosure volume must be greater than or equal to the minimum volume specified in this column. Application specific thermal considerations can require a larger enclosure.
- (8) Recommended Motor circuit protector - Instantaneous trip circuit breaker. The trip setting must be set to the input current of the drive and must be sized for the continuous current of the system.
- (9) Bulletin 140M with adjustable current range must have the current trip set to the minimum range so that the device does not trip.
- (10) Manual Self-Protected (Type E) Combination Motor Controller, UL listed for 480Y/277V and 600Y/347V AC Input. Not UL listed for use on 480V or 600V Delta/Delta, corner ground, or high-resistance ground systems.
- (11) Bulletin 140M must be frame C (C2E), frame D (D8F), or frame F (F8E).
- (12) Bulletin 140M must be frame D (D8F) or frame F (F8E).
- (13) When using a Manual Self-Protected (Type E) Combination Motor Controller, the drive must be installed in a ventilated or non-ventilated enclosure with the minimum volume specified in this column. Application specific thermal considerations can require a larger enclosure.
- (14) See Fuse Certification and Test Data in PowerFlex AC Drives in Common Bus Configurations Application Guidelines, publication [DRIVES-ATD02](#), for fuse self-certification and test data for Bussmann 170M and JKS fuses recommended for the DC bus fusing.

480 Volt AC and 650 Volt DC Input Protection Devices - Floor Mount Frames 8...10

Applied Rating ⁽¹⁾	Frame	Cont. Output Amps	Duty	Catalog Number	Output Overload Amps		AC Input Integral Semiconductor Fuse Size (170M) ⁽²⁾	DC Bay to Bay Integral Semiconductor Fuse Size (170M)	AC Input Protection Devices Recommended for Branch Circuit Protection (Does not apply to 21G Drives with Options)						DC Input Integral Semiconductor Fuse Size (170M) ⁽⁸⁾			
					1 min	3 sec			Continuous AC Input		Dual Element Time Delay Fuse		Non-Time Delay Fuse			Circuit Breaker Max Size ⁽⁶⁾	Motor Circuit Protector ⁽⁷⁾	
									Amps	Amps	1/Phase Min ⁽⁴⁾	2/Phase Min ⁽⁴⁾	1/Phase Min ⁽⁴⁾	2/Phase Min ⁽⁴⁾				Max ⁽⁵⁾
480V AC Input																		
300 Hp	8	370	Heavy	206...D430	555	666	349	1100	-	450	-	800	450	-	1100	1100	450	1600
350 Hp	8	430	Normal	206...D430	473	666	406	1100	-	550	-	900	550	-	1200	1200	550	1600
		414	Heavy	206...D485	621	745	391	1100	-	500	-	900	500	-	1200	1200	500	1600
		454	Heavy	206...D545	681	818	428	1100	-	550	-	1000	550	-	1300	1300	550	1600
400 Hp	8	485	Light	206...D430	534	-	458	1100	-	600	-	1000	600	-	1400	1400	600	1600
		485	Normal	206...D485	534	745	458	1100	-	600	-	1000	600	-	1400	1400	600	1600
		485	Heavy	206...D617	728	926	458	1100	-	600	-	1000	600	-	1400	1400	600	1600
450 Hp	8	545	Light	206...D485	600	-	514	1100	-	650	-	1200	650	-	1600	1600	650	1600
		545	Normal	206...D545	600	818	514	1100	-	650	-	1200	650	-	1600	1600	650	1600
		545	Heavy	206...D710	818	1065	514	1100	-	650	325	1200	650	325	1600	1600	650	1600
500 Hp	8	590	Light	206...D545	649	-	557	1100	-	700	-	1300	700	-	1700	1700	700	1600
		617	Normal	206...D617	679	926	582	1100	-	750	325	1300	750	325	1800	1800	800	1600
		617	Heavy	206...D740	926	1110	582	1100	-	750	375	1300	750	375	2400	1800	800	1600
600 Hp	8	710	Light	206...D617	781	-	670	1100	-	850	425	1500	850	425	2100	2100	900	1600
		710	Normal	206...D710	781	1065	670	1100	-	850	425	1500	850	425	2100	2100	900	1600
		765	Light	206...D710	842	-	722	1100	-	1000	500	1700	1000	500	2200	2200	1000	1600
700 Hp	8	740	Normal	206...D740	814	1110	698	1100	-	900	450	1600	900	450	2200	2200	900	1600
		800	Light	206...D740	880	-	755	1100	-	1000	500	1800	1000	500	1800	2400	1000	1600
600 Hp	9	710	Heavy	206...D800	1065	1278	670	1100	1400 ⁽³⁾	850	425	1500	850	425	2000	2000	850	1600 ⁽³⁾
700 Hp	9	795	Heavy	206...D960	1193	1440	750	1100	1400 ⁽³⁾	950	475	1700	950	475	2300	2300	950	1600 ⁽³⁾
750 Hp	9	800	Normal	206...D800	880	1278	755	1100	1400 ⁽³⁾	950	475	1700	950	475	2300	2300	950	1600 ⁽³⁾
800 Hp	9	800	Heavy	206...D1K0	1200	1568	755	1100	1400 ⁽³⁾	950	475	1700	950	475	2300	2300	950	1600 ⁽³⁾
		960	Light	206...D800	1056	-	906	1100	1400 ⁽³⁾	1150	575	2000	1150	575	2700	2700	1150	1600 ⁽³⁾
		960	Normal	206...D960	1056	1440	906	1100	1400 ⁽³⁾	1150	575	2000	1150	575	2700	2700	1150	1600 ⁽³⁾
		960	Heavy	206...D1K2	1440	1728	906	1100	1400 ⁽³⁾	1150	575	2000	1150	575	2700	2700	1150	1600 ⁽³⁾
900 Hp	9	1045	Light	206...D960	1150	-	986	1100	1400 ⁽³⁾	1250	625	2200	1250	625	3000	3000	1250	1600 ⁽³⁾
		1045	Normal	206...D1K0	1150	1568	986	1100	1400 ⁽³⁾	1250	625	2200	1250	625	3000	3000	1250	1600 ⁽³⁾
		1045	Heavy	206...D1K3	1568	2048	986	1100	1400 ⁽³⁾	1250	625	2200	1250	625	3000	3000	1250	1600 ⁽³⁾

continued on page 49

Applied Rating (1)	Cont. Output Amps	Duty	Catalog Number	Output Overload Amps		AC Input Integral Semiconductor Fuse Size (170M) (2)	DC Bay to Bay Integral Semiconductor Fuse Size (170M)	AC Input Protection Devices Recommended for Branch Circuit Protection (Does not apply to 21G Drives with Options)						Input Quantities		DC Input Integral Semiconductor Fuse Size (170M) (8)	
				1 min	3 sec			Dual Element Time Delay Fuse		Non-Time Delay Fuse		Circuit Breaker Max Size (6)	Motor Circuit Protector (7)	Continuous DC Input	Amps		
								1/Phase Min (4)	2/Phase Min (4)	1/Phase Min (4)	2/Phase Min (4)						Max (5)
480V AC Input (continued)																	
1000 Hp	9	1135	Light	206...D1K0	1249	1071	1100	1400 (3)	1350	675	2400	1350	675	3200	3200	1350	1600 (3)
		1135	Normal	206...D1K2	1249	1071	1100	1400 (3)	1350	675	2400	1350	675	3200	3200	1350	1600 (3)
		1135	Heavy	206...D1K4	1703	1071	1100	1400 (3)	1350	675	2400	1350	675	3200	3200	1350	1600 (3)
1100 Hp	9	1365	Light	206...D1K2	1502	1288	1100	1400 (3)	1600	800	2900	1600	800	3900	3900	1600	1600 (3)
		1365	Normal	206...D1K3	1502	1288	1100	1400 (3)	1600	800	2900	1600	800	3900	3900	1600	1600 (3)
		1270	Heavy	206...D1K5	1905	1199	1100	1400 (3)	1500	750	2700	1500	750	3600	3600	1500	1600 (3)
1250 Hp	9	1420	Light	206...D1K3	1562	1340	1100	1400 (3)	1700	850	3000	1700	850	4000	4000	1700	1600 (3)
		1420	Normal	206...D1K4	1562	1340	1100	1400 (3)	1700	850	3000	1700	850	4000	4000	1700	1600 (3)
		1540	Light	206...D1K4	1694	1453	1100	1400 (3)	1800	900	3300	1800	900	4400	4400	1800	1600 (3)
1350 Hp	9	1525	Normal	206...D1K5	1678	1439	1100	1400 (3)	1800	900	3200	1800	900	4300	4300	1800	1600 (3)
1500 Hp	10	1655	Light	206...D1K5	1821	1562	1100	1400 (3)	1950	975	3500	1950	975	4700	4700	1950	1600 (3)
1650 Hp	10	1730	Heavy	206...D2K0	2595	1633	1100	1400 (3)	2050	1025	3700	2050	1025	4900	4900	2050	1600 (3)
1750 Hp	10	2070	Normal	206...D2K0	2277	1953	1100	1400 (3)	2450	1225	4400	2450	1225	5900	5900	2450	1600 (3)
2000 Hp	10	2240	Light	206...D2K0	2464	2114	1100	1400 (3)	2650	1325	4800	2650	1325	6300	6300	2650	1600 (3)

(1) "Applied Rating" refers to the motor that is connected to the drive. For example, a "D430" drive can be used in Normal Duty mode on a 350 Hp motor, in Heavy Duty mode on a 300 Hp motor or in Light Duty mode on a 400 Hp motor. The drive can be programmed for each mode. Wiring and fuses can be sized based on the programmed mode. For any given drive catalog number, Normal Duty mode provides higher continuous current but smaller overload current with respect to Heavy Duty mode. See parameter 306 [Duty Rating]. See Specifications for an explanation of Duty Ratings.

(2) These AC line fuses (with blown fuse indicators) are included in the drive to provide drive short circuit protection. AC input protection devices for branch circuit protection based on US NEC are listed in the table. Each drive bay has one fuse per phase.

(3) Each drive bay has one fuse per DC line.

(4) Minimum protection device size is the lowest rated device that supplies maximum protection without nuisance tripping.

(5) Maximum protection device size is the highest rated device that supplies drive protection. For US NEC, minimum size is 125% of motor FLA. Ratings shown are maximum.

(6) Circuit Breaker - inverse time breaker. For US NEC, minimum size is 125% of motor FLA. Ratings shown are maximum.

(7) Recommended Motor circuit protector - instantaneous trip circuit breaker. The trip setting must be set to the input current of the drive and must be sized for the continuous current of the system.

(8) These DC line fuses (with blown fuse indicators) are included in the drive to provide drive short circuit protection.

600 Volt AC and 810V DC Input Protection Devices - Wall Mount Frames 3...7

Applied Rating (1)	Drive Sized For Normal Duty				Drive Sized For Heavy Duty				AC Input Protection Devices						DC Input Protection (14)		
	Catalog Number		Output Overload Amps		Catalog Number		Output Overload Amps		Continuous AC Input	Dual Element Time Delay Fuse		Circuit Breaker Max Size (6)	Circuit Breaker, Dual Element Time Delay Fuse	140M Type E Combination Motor Controller with Adjustable Current Range (9) (10)			
	(x = F or G)	1 min	3 sec	(x = F or G)	1 min	3 sec	Min (2)	Max (3)		Min (2)	Max (3)			Motor Circuit Protector (8)		Cat. No.	Min Enclosure Volume (in. 3) (13)
600 Volt AC Input																	
0.5 Hp	3	0.9				20x...E1P7	1.4	2.6	0.8	1	2	3	3	4800	1	M-xxx-B16 (11)	9086
1 Hp	3	1.7				20x...E1P7	2.6	4.1	1.6	2	4	5	5	4800	2	M-xxx-B25 (11)	9086
2 Hp	3	2.7				20x...E2P7	3.0	4.1	2.5	3	6	8	8	4800	3	M-xxx-B40 (11)	9086
3 Hp	3	3.9				20x...E3P9	4.3	5.9	3.7	5	8	11 (4), 10 (5)	11 (4), 20 (5)	4800	5	M-D8E-B63	9086
5 Hp	3	6.1				20x...E6P1	6.7	9.2	5.7	7	13	7	20	4800	10	M-D8E-B63	9086
7.5 Hp	3	9				20x...E9P0	9.9	13.5	8.4	11	19	25	30	4800	15	M-xxx-C10 (12)	9086
10 Hp	3	11				20x...E011	12.1	16.5	10.3	13	23	30	40	4800	15	M-xxx-C16 (12)	9086
15 Hp	3	17				20x...E017	18.7	25.5	16.0	20	36	50	50	4800	20	M-F8E-C20	9086
20 Hp	3	22				20x...E022	24.2	33.0	20.7	26	46	60	70	4800	30	M-F8E-C25	9086
4	22					20x...E027	33.0	40.5	20.7	26	46	60	70	4800	30	M-F8E-C25	9086
25 Hp	4	27				20x...E027	29.7	40.5	25.3	32	57	75	80	4800	35	M-F8E-C32	9086
30 Hp	4	32				20x...E032	35.2	48.0	30.0	38	68	90	100	4800	40	M-F8E-C32	9086
5	32					20x...E041	45.1	61.5	30.0	38	68	90	100	7200	40	M-F8E-C32	13630
40 Hp	5	41				20x...E052	61.5	78.0	38.5	48	87	115	120	7200	50		
50 Hp	5	52				20x...E052	57.2	78.0	48.8	61	110	145	150	7200	65		
7.5 Hp	6	9.1				20x...E012	13.7	18.0	8.5	11	19	25	30		15	M-xxx-C16 (12)	14400
10 Hp	6	12				20x...E018	18.0	27.0	11.3	14	25	35	40		15	M-xxx-C16 (12)	14400
15 Hp	6	18				20x...E023	27.0	34.5	16.9	21	38	50	60		25	M-F8E-C20	14400
20 Hp	6	23				20x...E028	34.5	42.0	21.6	27 (4), 25 (5)	49 (4), 50 (5)	65	70		30	M-F8E-C25	14400
6	24					20x...E024	26.4	36.0	22.5	28	51	70	70		30	M-F8E-C25	14400
6	22					20x...E024	33.0	39.6	20.7	26	46	60	70		30	M-F8E-C25	14400
6	28					20x...E033	42.0	50.4	26.3	35	60	80	80		35	M-F8E-C32	14400
30 Hp	6	33				20x...E042	49.5	63.0	31.0	40	70	95	100		40	M-F8E-C32	14400
40 Hp	6	42				20x...E053	63.0	79.5	39.4	50	90	120	120		50		
50 Hp	6	53 (4), 52 (5)				20x...E063	78.0	94.5	49.8 (4), 48.8 (5)	60	110	150 (4), 145 (5)	150		65		
60 Hp	6	63				20x...E077	94.5	115.5	59.1	75	135	175	180		75		

continued on page 51

Applied Rating (1)	Drive Sized For Normal Duty		Drive Sized For Heavy Duty		AC Input Protection Devices						DC Input Protection (14)		
	Catalog Number	Output Overload Amps	Catalog Number	Output Overload Amps	Continuous AC Input Amps	Dual Element Time Delay Fuse		Circuit Breaker Max Size (6)	Circuit Breaker, Dual Element Time Delay Fuse	Motor Circuit Protector (8)		140M Type E Combination Motor Controller with Adjustable Current Range (9) (10)	
						Min (2)	Max (3)					Cat. No.	Min Enclosure Volume (in. 3) (13)
75 Hp	20x...E077	84.7	20x...E099	115.5	72.3	90	165	215	220	95		Non-Time Delay Fuse	
100 Hp	20x...E099	108.9	20x...E125	148.5	92.9	115	210	280	280	120		HSI150	
125 Hp	20x...E125	137.5	20x...E144	187.5	117.4	145	265	350	360	150		HSI225	
150 Hp	20x...E144	158.4	20x...E192	216.0	135.2	170	300	400	400	170		HSI250	
200 Hp	20x...E192	211.2	20x...E242	288.0	180.3	225	405	540	550	230		HSI350	
250 Hp	20x...E242	266.2	20x...E289	363.0	227.2	285	510	680	690	285		HSI400	
300 Hp	20x...E289	317.9		433.5	271.3	340	600	800	800	340		HSI500	

(1) "Applied Rating" refers to the motor that is connected to the drive. For example, a "E063" drive can be used in Normal Duty mode on a 60 Hp motor, in Heavy Duty mode on a 50 Hp motor. The drive can be programmed for each mode. Wiring and fuses can be sized based on the programmed mode. For any given drive catalog number, Normal Duty mode provides higher continuous current but smaller overload current with respect to Heavy Duty mode. See Specifications for an explanation of Duty Ratings.

(2) Minimum protection device size is the lowest rated device that supplies maximum protection without nuisance tripping.

(3) Maximum protection device size is the highest rated device that supplies drive protection. For US NEC, minimum size is 125% of motor F.L.A. Ratings shown are maximum.

(4) Normal duty.

(5) Heavy duty.

(6) Circuit Breaker - inverse time breaker. For US NEC, minimum size is 125% of motor F.L.A. Ratings shown are maximum.

(7) When using a circuit breaker or time-delay fuse with a drive installed in a ventilated enclosure, the enclosure volume must be greater than or equal to the minimum volume specified in this column. Application specific thermal considerations can require a larger enclosure.

(8) Recommended Motor circuit protector - Instantaneous trip circuit breaker. The trip setting must be set to the input current of the drive and must be sized for the continuous current of the system.

(9) Bulletin 140M with adjustable current range must have the current trip set to the minimum range so that the device does not trip.

(10) Manual Self-Protected (Type E) Combination Motor Controller, UL listed for 480Y/277V and 600Y/347V AC Input. Not UL listed for use on 480V or 600V Delta/Delta, corner ground, or high-resistance ground systems.

(11) Bulletin 140M must be frame C (C2E), frame D (D8F), or frame F (F8E).

(12) Bulletin 140M must be frame D (D8F) or frame F (F8E).

(13) When using a Manual Self-Protected (Type E) Combination Motor Controller, the drive must be installed in a ventilated or non-ventilated enclosure with the minimum volume specified in this column. Application specific thermal considerations can require a larger enclosure.

(14) See Fuse Certification and Test Data in PowerFlex AC Drives in Common Bus Configurations Application Guidelines, publication [DRIVES-A1002](#), for fuse self-certification and test data for Bussmann 170M and JKS fuses recommended for the DC bus fusing.

600 Volt AC and 810V DC Input Protection Devices - Floor Mount Frames 8...10

Applied Rating ⁽¹⁾ Frame	Cont. Output Amps	Duty	Catalog Number	Output Overload Amps		AC Input Integral Semiconductor Fuse Size (170M) ⁽²⁾	DC Bay to Bay Integral Semiconductor Fuse Size (170M6648)	AC Input Protection Devices Recommended for Branch Circuit Protection <small>(Does not apply to 21G Drives with Options)</small>						DC Input Integral Semiconductor Fuse Size (170M6253) ⁽⁷⁾			
				1 min	3 sec			Dual Element Time Delay Fuse		Non-Time Delay Fuse		Circuit Breaker Max Size ⁽⁵⁾	Motor Circuit Protector ⁽⁶⁾				
								1/Phase Min ⁽³⁾	2/Phase Min ⁽³⁾	Max ⁽⁴⁾	1/Phase Min ⁽³⁾				2/Phase Min ⁽³⁾	Max ⁽⁴⁾	
Continuous AC Input		Amps		Amps		Amps		Amps		Amps		Amps					
600V AC Input																	
250Hp	8	272	Heavy	206...E295	408	490	257	900	350	175	600	350	175	800	800	350	1000
300Hp	8	295	Heavy	206...E355	443	533	278	900	350	175	700	350	175	900	900	350	1000
350Hp	8	295	Normal	206...E295	325	490	278	900	400	200	700	400	200	1000	1000	400	1000
		355	Light	206...E295	391	-	335	900	450	225	800	450	225	1100	1100	450	1000
400Hp	8	355	Normal	206...E355	391	533	335	900	450	225	800	450	225	1100	1100	450	1000
		329	Heavy	206...E395	494	593	310	900	400	200	700	400	200	1000	1000	400	1000
400Hp	8	355	Heavy	206...E435	533	639	335	900	450	225	800	450	225	1100	1100	450	1000
		395	Light	206...E355	435	-	373	900	500	250	900	500	250	1200	1200	500	1000
400Hp	8	395	Normal	206...E395	435	593	373	900	500	250	900	500	250	1200	1200	500	1000
		395	Heavy	206...E460	593	711	373	900	500	250	900	500	250	1200	1200	500	1000
450Hp	8	435	Light	206...E395	479	-	411	900	550	275	1000	550	275	1300	1300	550	1000
		435	Normal	206...E435	479	639	411	900	500	250	900	500	250	1200	1200	500	1000
450Hp	8	425	Heavy	206...E510	638	765	401	900	550	275	1000	550	275	1300	1300	550	1000
		460	Light	206...E435	506	-	434	900	550	275	1000	550	275	1300	1300	550	1000
500Hp	8	510	Light	206...E460	561	-	481	900	650	325	1100	650	325	1500	1500	650	1000
		460	Normal	206...E460	506	711	434	900	550	275	1000	550	275	1300	1300	550	1000
550Hp	8	510	Normal	206...E510	561	765	481	900	650	325	1100	650	325	1500	1500	650	1000
		545	Light	206...E510	600	-	514	900	650	325	1200	650	325	1600	1600	650	1000
500Hp	9	510	Heavy	206...E595	765	918	481	1000	600	300	1100	600	300	1400	1400	600	1000
		595	Heavy	206...E630	893	1071	562	1000	700	350	1300	700	350	1700	1700	700	1000
600Hp	9	595	Normal	206...E595	655	918	562	1000	700	350	1300	700	350	1700	1700	700	1000
		630	Heavy	206...E760	945	1149	595	1000	750	375	1300	750	375	1800	1800	750	1000
700Hp	9	630	Normal	206...E630	693	1071	595	1000	750	375	1300	750	375	1800	1800	750	1000
		595	Light	206...E595	693	-	651	1000	800	400	1500	800	400	2000	2000	800	1000
750Hp	9	700	Heavy	206...E825	1050	1260	661	1000	850	425	1500	850	425	2000	2000	850	1000
		760	Heavy	206...E900	1140	1368	717	1000	900	450	1600	900	450	2200	2200	900	1000
800Hp	9	760	Normal	206...E760	836	1140	717	1000	900	450	1600	900	450	2200	2200	900	1000
		760	Light	206...E630	836	-	717	1000	900	450	1600	900	450	2200	2200	900	1000

continued on page 53

Applied Rating ⁽¹⁾	Cont. Output Amps	Duty	Catalog Number	Output Overload Amps		AC Input Integral Semiconductor Fuse Size (170M) ⁽²⁾	DC Bay to Bay Integral Semiconductor Fuse Size (170M6648)	AC Input Protection Devices Recommended for Branch Circuit Protection (Does not apply to 21G Drives with Options)						DC Input Integral Semiconductor Fuse Size (170M6253) ⁽⁷⁾				
				1 min	3 sec			Continuous AC Input Amps	Dual Element Time Delay Fuse		Non-Time Delay Fuse		Circuit Breaker Max Size ⁽⁵⁾		Motor Circuit Protector ⁽⁶⁾			
									1/Phase Min ⁽³⁾	2/Phase Min ⁽³⁾	Max ⁽⁴⁾	1/Phase Min ⁽³⁾				2/Phase Min ⁽³⁾	Max ⁽⁴⁾	
600V AC Input (continued)													810V DC Input (continued)					
900 Hp	9	815	Heavy	206...E980	1223	1470	769	900	1000	950	475	1700	950	475	2300	2300	950	1000
		825	Normal	206...E825	908	1260	779	900	1000	950	475	1800	950	475	2300	2300	950	1000
		835	Light	206...E760	919	-	788	900	1000	1000	500	1800	1000	500	2400	2400	1000	1000
950 Hp	9	900	Normal	206...E900	990	1368	849	900	1000	1050	525	1900	1050	525	2500	2500	1050	1000
		900	Light	206...E825	990	-	849	900	1000	1050	525	1900	1050	525	2500	2500	1050	1000
1000 Hp	9	980	Normal	206...E980	1078	1470	925	900	1000	1150	575	2100	1150	575	2800	2800	1150	1000
		980	Light	206...E900	1078	-	925	900	1000	1150	575	2100	1150	575	2800	2800	1150	1000
		920	Heavy	206...E1K1	1380	1665	868	900	1000	1100	550	2000	1100	550	2600	2600	1100	1000
1100 Hp	9	1045	Light	206...E980	1150	-	986	900	1000	1250	625	2200	1250	625	3000	3000	1250	1000
		1110	Normal	206...E1K1	1221	1665	1048	900	1000	1300	650	2400	1300	650	3100	3100	1300	1000
1200 Hp	10	1220	Light	206...E1K1	1342	1464	1151	900	1000	1450	725	2600	1450	725	3500	3500	1450	1000
1250 Hp	10	1190	Heavy	206...E1K4	1785	2145	1123	900	1000	1400	700	2500	1400	700	3400	3400	1400	1000
1400 Hp	10	1430	Normal	206...E1K4	1573	2145	1350	900	1000	1700	850	3000	1700	850	4100	4100	1700	1000
1500 Hp	10	1530	Light	206...E1K4	1683	1836	1444	900	1000	1800	900	3200	1800	900	4300	4300	1800	1000

(1) "Applied Rating" refers to the motor that is connected to the drive. For example, a "420" drive can be used in Normal Duty mode on a 450 Hp motor, in Heavy Duty mode on a 350 Hp motor or in Light Duty mode on a 500 Hp motor. The drive can be programmed for each mode. Wiring and fuses can be sized based on the programmed mode. For any given drive catalog number, Normal Duty mode provides higher continuous current but smaller overload current with respect to Heavy Duty mode. See parameter 306 [Duty Rating]. See Specifications for an explanation of Duty Ratings.

(2) These AC line fuses (with blown fuse indicators) are included in the drive to provide drive short circuit protection. AC input protection devices for branch circuit protection based on US NEC are listed in the table. Each drive bay has one fuse per phase.

(3) Minimum protection device size is the lowest rated device that supplies maximum protection without nuisance tripping.

(4) Maximum protection device size is the highest rated device that supplies drive protection. For US NEC, minimum size is 125% of motor FLA. Ratings shown are maximum.

(5) Circuit Breaker - inverse time breaker. For US NEC, minimum size is 125% of motor FLA. Ratings shown are maximum.

(6) Recommended Motor circuit protector - instantaneous trip circuit breaker. The trip setting must be set to the input current of the drive and must be sized for the continuous current of the system.

(7) These DC line fuses (with blown fuse indicators) are included in the drive to provide drive short circuit protection.

690 Volt AC and 932V DC Input Protection Devices - Wall Mount Frames 6 and 7

Applied Rating ⁽¹⁾	Frame	Drive Sized For Normal Duty		Drive Sized For Heavy Duty		AC Input Protection Devices				DC Input Protection						
		Cont. Output Amps	Catalog Number (x = F or G)	Output Overload Amps 1 min	Output Overload Amps 3 sec	Catalog Number (x = F or G)	Output Overload Amps 1 min	Output Overload Amps 3 sec	Continuous AC Input Amps	Dual Element Time Delay Fuse Min ⁽²⁾	Non-Time Delay Fuse Max ⁽⁵⁾	Non-Time Delay Fuse Max ⁽⁵⁾	Continuous DC Input Amps	Non-Time Delay Fuse		
690 Volt AC Input																
5.5 kW	6	9				20x...F011	13.5	18.0	8.4	11	19	11	25	30	15	HS115
7.5 kW	6	12		13.2	18.0	20x...F011	18.0	22.5	11.2	14	25	14	35	40	15	HS120
11 kW	6	15		16.5	22.5	20x...F015	22.5	30.0	14.1	18	32	18	40	50	20	HS125
15 kW	6	20		22.0	30.0	20x...F020	30.0	36.0	18.7	23	42	23	55	60	25	HS135
18.5 kW	6	23		25.3	34.5	20x...F023	34.5	45.0	21.6	27 ⁽³⁾ , 25 ⁽⁴⁾	48 ⁽³⁾ , 50 ⁽⁴⁾	27 ⁽³⁾ , 25 ⁽⁴⁾	65	70	30	HS140
22 kW	6	30		33.0	45.0	20x...F030	45.0	54.0	28.1	35	65	35	85	90	40	HS150
30 kW	6	34		37.4	51.0	20x...F034	51.0	69.0	31.9	40	70	40	95	100	40	HS160
37 kW	6	46		50.6	69.0	20x...F046	69.0	82.8	43.1	55	95	55	130	130	55	HS180
45 kW	6	50		55.0	75.0	20x...F050	75.0	91.5	46.9	60	105	60	140	150	60	HS190
55 kW	6	61		67.1	91.5	20x...F061	91.5	123.0	57.2	70	130	70	170	180	75	HS1100
75 kW	6	82		90.2	123.0	20x...F082	123.0	147.6	76.8	95	175	95	230	240	100	HS1150
90 kW	6	98		107.8	147.0	20x...F098	147.0	178.5	91.8	115	205	115	275	280	115	HS1175
110 kW	6	119		130.9	178.5	20x...F119	178.5	214.2	111.5	140	250	140	335	340	140	HS1200
132 kW	6	142		156.2	213.0	20x...F142	213.0		133.1	165	300	165	400	400	170	HS1250
160 kW	7	171		188.1	256.5	20x...F171	256.5	318.0	160.2	200	360	200	480	490	205	HS1250
200 kW	7	212		233.2	318.0	20x...F212	318.0	394.5	198.7	250	445	250	595	600	250	HS1500
250 kW	7	263		289.3	394.5	20x...F263	394.5		246.5	310	555	310	740	740	310	HS1500

(1) "Applied Rating" refers to the motor that is connected to the drive. For example, a "F061" drive can be used in Normal Duty mode on a 55 kW motor, in Heavy Duty mode on a 45 kW motor. The drive can be programmed for each mode. Wiring and fuses can be sized based on the programmed mode. For any given drive catalog number, Normal Duty mode provides higher continuous current but smaller overload current with respect to Heavy Duty mode. See parameter 306 [Duty Rating]. See Specifications for an explanation of Duty Ratings.

(2) Minimum protection device size is the lowest rated device that supplies maximum protection without nuisance tripping.

(3) Normal duty.

(4) Heavy duty.

(5) Maximum protection device size is the highest rated device that supplies drive protection. For US NEC, minimum size is 125% of motor FLA. Ratings shown are maximum.

(6) Circuit Breaker - inverse time breaker. For US NEC, minimum size is 125% of motor FLA. Ratings shown are maximum.

(7) Recommended Motor circuit protector - Instantaneous trip circuit breaker. The trip setting must be set to the input current of the drive and must be sized for the continuous current of the system.

690 Volt AC and 932V DC Input Protection Devices - Floor Mount Frames 8...10

Applied Rating ⁽¹⁾	Frame	Cont. Output Amps	Duty	Catalog Number	Output Overload Amps		AC Input Integral Semiconductor Fuse Size (170M) ⁽²⁾	DC Bay to Bay Integral Semiconductor Fuse Size (170M6648)	AC Input Protection Devices Recommended for Branch Circuit Protection (Does not apply to 21G Drives with Options)						DC Input Integral Semiconductor Fuse Size (170M6253) ⁽⁷⁾		
					1 min	3 sec			Continuous AC Input		Dual Element Time Delay Fuse		Non-Time Delay Fuse			Circuit Breaker Max Size ⁽⁵⁾	Motor Circuit Protector ⁽⁶⁾
									Amps	Amps	1/Phase Min ⁽³⁾	2/Phase Min ⁽³⁾	1/Phase Min ⁽³⁾	2/Phase Min ⁽³⁾			
690V AC Input																	
200kW	8	215	Heavy	206...F265	323	375	203	900	250	125	500	250	125	600	600	250	1000
250kW	8	265	Normal	206...F265	292	375	250	900	300	150	600	300	150	800	800	300	1000
	8	265	Heavy	206...F330	398	473	250	900	300	150	600	300	150	800	800	300	1000
300kW	8	308	Heavy	206...F370	462	555	290	900	400	200	700	400	200	900	900	400	1000
315kW	8	330	Light	206...F265	363	-	311	900	400	200	700	400	200	900	900	400	1000
	8	330	Normal	206...F330	363	473	311	900	400	200	700	400	200	900	900	400	1000
355kW	8	370	Light	206...F330	407	-	349	900	450	225	800	450	225	1100	1100	450	1000
	8	370	Normal	206...F370	407	555	349	900	450	225	800	450	225	1100	1100	450	1000
	8	370	Heavy	206...F415	555	639	349	900	450	225	800	450	225	1100	1100	450	1000
375kW	8	375	Heavy	206...F460	563	675	353	900	450	225	800	450	225	1100	1100	450	1000
400kW	8	410	Light	206...F370	451	-	386	900	500	250	900	500	250	1200	1200	500	1000
	8	415	Normal	206...F415	457	639	391	900	500	250	900	500	250	1200	1200	500	1000
	8	413	Heavy	206...F500	620	750	389	900	500	250	900	500	250	1200	1200	500	1000
450kW	8	460	Light	206...F415	506	-	433	900	550	275	1000	550	275	1300	1300	550	1000
	8	460	Normal	206...F460	506	675	433	900	550	275	1000	550	275	1300	1300	550	1000
500kW	8	500	Light	206...F460	550	-	471	900	600	300	1100	600	300	1500	1500	600	1000
	8	500	Normal	206...F500	550	750	471	900	600	300	1100	600	300	1500	1500	600	1000
530kW	8	530	Light	206...F500	583	-	499	900	650	325	1200	650	325	1500	1500	650	1000
450kW	9	460	Heavy	206...F590	690	885	433	1000	550	275	1000	550	275	1300	1300	550	1000
500kW	9	500	Heavy	206...F650	750	975	471	1000	600	300	1100	600	300	1400	1400	600	1000
560kW	9	590	Heavy	206...F710	885	1065	556	1000	700	350	1300	700	350	1700	1700	700	1000
	9	590	Normal	206...F590	649	885	556	1000	700	350	1300	700	350	1700	1700	700	1000
630kW	9	650	Heavy	206...F765	975	1170	612	1000	750	375	1400	750	375	1800	1800	750	1000
	9	650	Normal	206...F650	715	975	612	1000	750	375	1400	750	375	1800	1800	750	1000
	9	650	Light	206...F590	715	-	612	1000	750	375	1400	750	375	1800	1800	750	1000
710kW	9	750	Heavy	206...F795	1125	1350	706	1000	900	450	1600	900	450	2100	2100	900	1000
	9	710	Normal	206...F710	781	1065	669	1000	900	450	1600	900	450	2100	2100	900	1000
	9	710	Light	206...F650	781	-	669	1000	900	450	1600	900	450	2100	2100	900	1000
750kW	9	765	Normal	206...F765	842	1170	721	1000	900	450	1600	900	450	2200	2200	900	1000

continued on page 56

Applied Rating (1)	Frame	Cont. Output Amps	Duty	Catalog Number	Output Overload Amps		AC Input Integral Semiconductor Fuse Size (170M) (2)	DC Bay to Bay Integral Semiconductor Fuse Size (170M6648)	AC Input Protection Devices Recommended for Branch Circuit Protection (Does not apply to 21G Drives with Options)						DC Input Integral Semiconductor Fuse Size (170M6253) (7)		
					1 min	3 sec			Continuous AC Input Amps		Dual Element Time Delay Fuse		Non-Time Delay Fuse			Circuit Breaker Max Size (5)	Motor Circuit Protector (6)
690V AC Input (continued)														932V DC Input (continued)			
800 kW	9	795	Heavy	206...F960	1193	1440	749	1000	950	475	1700	950	475	2200	2200	875	1000
		795	Normal	206...F795	875	1350	749	1000	950	475	1700	950	475	2200	2200	875	1000
		790	Light	206...F710	869	-	744	1000	950	475	1700	950	475	2200	2200	869	1000
850 kW	9	860	Light	206...F765	946	-	810	1000	1000	500	1800	1000	500	2400	2400	946	1000
900 kW	9	960	Normal	206...F960	1056	1440	904	1000	1150	575	2000	1150	575	2700	2700	1056	1000
		960	Light	206...F795	1056	-	904	1000	1150	575	2000	1150	575	2700	2700	1056	1000
1000 kW	10	865	Heavy	206...F1K0	1298	1560	815	1000	1000	500	1800	1000	500	2400	2400	952	1000
	9	1020	Light	206...F795	1122	-	904	1000	1200	600	2200	1200	600	2900	2900	1056	1000
1100 kW	10	1040	Normal	206...F1K0	1144	1560	980	1000	1250	625	2200	1250	625	2900	2900	1144	1000
1120 kW	10	1150	Light	206...F1K0	1265	1380	1083	1000	1350	675	2400	1350	675	3200	3200	1265	1000
1400 kW	10	1160	Heavy	206...F1K4	1740	2100	1093	1000	1350	675	2500	1350	675	3300	3300	1276	1000
1500 kW	10	1400	Normal	206...F1K4	1540	2100	1319	1000	1650	825	3000	1650	825	4000	4000	1540	1000
	10	1485	Light	206...F1K4	1634	1782	1399	1000	1750	875	3100	1750	875	4200	4200	1634	1000

(1) "Applied Rating" refers to the motor that is connected to the drive. For example, a "F400" drive can be used in Normal Duty mode on a 400 kW motor, in Heavy Duty mode on a 355 kW motor or in Light Duty mode on a 450 kW motor. The drive can be programmed for each mode. Wiring and fuses can be sized based on the programmed mode. For any given drive catalog number, Normal Duty mode provides higher continuous current but smaller overload current with respect to Heavy Duty mode. See parameter 306 [Duty Rating]. See Specifications for an explanation of Duty Ratings.

(2) These AC line fuses (with blown fuse indicators) are included in the drive to provide drive short circuit protection. AC input protection devices for branch circuit protection based on US NEC are listed in the table. Each drive bay has one fuse per phase. (3) Minimum protection device size is the lowest rated device that supplies maximum protection without nuisance tripping.

(4) Maximum protection device size is the highest rated device that supplies drive protection. For US NEC, minimum size is 125% of motor FLA. Ratings shown are maximum.

(5) Circuit Breaker - inverse time breaker. For US NEC, minimum size is 125% of motor FLA. Ratings shown are maximum.

(6) Recommended Motor circuit protector - instantaneous trip circuit breaker. The trip setting must be set to the input current of the drive and must be sized for the continuous current of the system.

(7) These DC line fuses (with blown fuse indicators) are included in the drive to provide drive short circuit protection.

Short-Circuit Current Ratings for Drives with Options

Default ratings (no added protection) shown. A “•” indicates ratings that can be achieved with additional protection.

400V AC Input

Drive Catalog Number	Frame	Duty Cycle	kW	Short-Circuit Current Rating (kA)			
				Circuit Breaker Only (P3) ⁽¹⁾	Circuit Breaker with Input Contactor (P3 with P11) ⁽¹⁾	Molded Case Switch Only (P5) ⁽²⁾	Molded Case Switch with Input Contactor (P5 with P11) ⁽²⁾
400 Volt AC Input							
21G...C460	8	LD	315	100	30	65 or • 100 w/700...800 A Class L fuse	5 or • 30 w/700...1200 A Class L fuse • 30 w/700...1200 A CB
		ND	250	100	30 or • 65 w/600 A Class J fuse	65	5 or • 65 w/600 A Class J fuse • 30 w/600...1000 A Class L fuse • 30 w/600...1200 A CB
		HD	200	100	5 or • 100 w/500...600 A Class J fuse • 18 w/600...800 A Class L fuse • 18 w/500 A CB	65	5 or • 100 w/500...600 A Class J fuse • 18 w/600...800 A Class L fuse • 18 w/500 A CB
21G...C540	8	LD	315	100	30	65 or • 100 w/750...800 A Class L fuse	5 or • 30 w/750...1300 A Class L fuse • 30 w/800...1200 A CB
		ND	315	100	30	65 or • 100 w/700...800 A Class L fuse	5 or • 30 w/700...1200 A Class L fuse • 30 w/700...1200 A CB
		HD	250	100	30 or • 65 w/600 A Class J fuse	65	5 or • 65 w/600 A Class J fuse • 30 w/600...1000 A Class L fuse • 30 w/600...1200 A CB
21G...C567	8	LD	355	100	30	65 or • 100 w/800 A Class L fuse	5 or • 30 w/800...1300 A Class L fuse • 30 w/800...1200 A CB
		ND	315	100	30	65 or • 100 w/750...800 A Class L fuse	5 or • 30 w/750...1200 A Class L fuse • 30 w/800...1200 A CB
		HD	250	100	30 or • 65 w/600 A Class J fuse	65	5 or • 65 w/600 A Class J fuse • 30 w/600...1000 A Class L fuse • 30 w/600...1200 A CB
21G...C650	8	LD	400	100	42	65 or • 100 w/1000...1200 A Class L fuse	5 or • 42 w/1000...1600 A Class L fuse • 42 w/1000...1200 A CB
		ND	355	100	42	65 or • 100 w/850...1200 A Class L fuse	5 or • 42 w/850...1400 A Class L fuse • 42 w/900...1200 A CB
		HD	315	100	30	65 or • 100 w/700...800 A Class L fuse	5 or • 30 w/700...1200 A Class L fuse • 30 w/700...1200 A CB
21G...C750	8	LD	450	100	42	65 or • 100 w/1000...1200 A Class L fuse	5 or • 42 w/1000...1700 A Class L fuse • 42 w/1000...1200 A CB
		ND	400	100	42	65 or • 100 w/1000...1200 A Class L fuse	5 or • 42 w/1000...1600 A Class L fuse • 42 w/1000...1200 A CB
		HD	315	100	30	65 or • 100 w/700...800 A Class L fuse	5 or • 30 w/750...1300 A Class L fuse • 30 w/800...1200 A CB
21G...C770	8	LD	450	100	42	65 or • 100 w/1000...1200 A Class L fuse	5 or • 42 w/1100...1800 A Class L fuse • 42 w/1100...1200 A CB
		ND	400	100	42	65 or • 100 w/1000...1200 A Class L fuse	5 or • 42 w/1000...1700 A Class L fuse • 42 w/1000...1200 A CB
		HD	355	100	42	65 or • 100 w/700...800 A Class L fuse	5 or • 42 w/800...1400 A Class L fuse • 42 w/800...1200 A CB

continued on [page 58](#)

Drive Catalog Number	Frame	Duty Cycle	kW	Short-Circuit Current Rating (kA)			
				Circuit Breaker Only (P3) ⁽¹⁾	Circuit Breaker with Input Contactor (P3 with P11) ⁽¹⁾	Molded Case Switch Only (P5) ⁽²⁾	Molded Case Switch with Input Contactor (P5 with P11) ⁽²⁾
400 Volt AC Input							
21G...C910	9	LD	560	100			
		ND	500	100			
		HD	400	100			
21G...C1K0	9	LD	630	100			
		ND	560	100			
		HD	500	100			
21G...C1K1	9	LD	710	100			
		ND	630	100			
		HD	500	100			
21G...C1K2	9	LD	800	100			
		ND	710	100			
		HD	560	100			
21G...C1K4	9	LD	850	100			
		ND	800	100			
		HD	630	100			
21G...C1K5	9	LD	900	100			
		ND	850	100			
		HD	710	100			
21G...C1K6	10	LD	1000	N/A			
		ND	900	N/A			
		HD	710	N/A			
21G...C2K1	10	LD	1400	N/A			
		ND	1250	N/A			
		HD	1000	N/A			

- (1) These circuit breakers are considered Branch Circuit Protection for the unit.
 (2) No additional protection is provided with the P5 Molded Case Switch option. Branch circuit protection is required based on NEC guidelines.

480V AC Input

Drive Catalog Number	Frame	Duty Cycle	Hp	Short-Circuit Current Rating (kA)			
				Circuit Breaker Only (P3) ⁽¹⁾	Circuit Breaker with Input Contactor (P3 with P11) ⁽¹⁾	Molded Case Switch Only (P5) ⁽²⁾	Molded Case Switch with Input Contactor (P5 with P11) ⁽²⁾
480 Volt AC Input							
21G...D430	8	LD	400	100	30 or • 65 w/600 A Class J fuse	65	5 or • 65 w/600 A Class J fuse • 30 w/600...1000 A Class L fuse • 30 w/600...1200 A CB
		ND	350	100	30 or • 65 w/550...600 A Class J fuse	65	30 or • 65 w/550...600 A Class J fuse
		HD	300	100	5 or • 100 w/450...600 A Class J fuse • 18 w/600...800 A Class L fuse • 18 w/500 A CB	65	5 or • 100 w/500...600 A Class J fuse • 18 w/600...800 A Class L fuse • 18 w/500 A CB
21G...D485	8	LD	450	100	30	65 or • 100 w/800 A Class L fuse	5 or • 30 w/650...1200 A Class L fuse • 30 w/700...1200 A CB
		ND	400	100	30 or • 65 w/600 A Class J fuse	65	5 or • 65 w/600 A Class J fuse • 30 w/600...1000 A Class L fuse • 30 w/600...1200 A CB
		HD	350	100	5 or • 100 w/500...600 A Class J fuse • 18 w/600...900 A Class L fuse	65	5 or • 100 w/500...600 A Class J fuse • 18 w/600...900 A Class L fuse

continued on [page 59](#)

Drive Catalog Number	Frame	Duty Cycle	Hp	Short-Circuit Current Rating (kA)			
				Circuit Breaker Only (P3) ⁽¹⁾	Circuit Breaker with Input Contactor (P3 with P11) ⁽¹⁾	Molded Case Switch Only (P5) ⁽²⁾	Molded Case Switch with Input Contactor (P5 with P11) ⁽²⁾
480 Volt AC Input							
21G...D545	8	LD	500	100	30	65 or • 100 w/800 A Class L fuse	5 or • 30 w/700...1300 A Class L fuse • 30 w/700...1200 A CB
		ND	450	100	30	65 or • 100 w/650...800 A Class L fuse	5 or • 30 w/650...1200 A Class L fuse • 30 w/700...1200 A CB
		HD	350	100	30 or • 65 w/550...600 A Class J fuse	65	5 or • 65 w/550...600 A Class J fuse • 30 w/600...1000 A Class L fuse • 30 w/600...1200 A CB
21G...D617	8	LD	600	100	42	65 or • 100 w/850...1200 A Class L fuse	5 or • 42 w/850...1500 A Class L fuse • 42 w/900...1200 A CB
		ND	500	100	30	65 or • 100 w/750...800 A Class L fuse	5 or • 30 w/750...1300 A Class L fuse • 30 w/800...1200 A CB
		HD	400	100	30 or • 65 w/600 A Class J fuse	65	5 or • 65 w/600 A Class J fuse • 30 w/600...1000 A Class L fuse • 30 w/600...1200 A CB
21G...D710	8	LD	650	100	42	65 or • 100 w/1000...1200 A Class L fuse	5 or • 42 w/1000...1700 A Class L fuse • 42 w/1000...2000 A CB
		ND	600	100	42	65 or • 100 w/850...1200 A Class L fuse	5 or • 42 w/850...1500 A Class L fuse • 42 w/900...1200 A CB
		HD	450	100	30	65 or • 100 w/650...800 A Class L fuse	5 or • 30 w/650...1200 A Class L fuse • 30 w/700...1200 A CB
21G...D740	8	LD	700	100	42	65 or • 100 w/1000...1200 A Class L fuse	5 or • 42 w/1000...1700 A Class L fuse • 42 w/1000...2000 A CB
		ND	650	100	42	65 or • 100 w/900...1200 A Class L fuse	5 or • 42 w/900...1600 A Class L fuse • 42 w/900...2000 A CB
		HD	500	100	30	65 or • 100 w/750...800 A Class L fuse	5 or • 30 w/750...1300 A Class L fuse • 30 w/800...1200 A CB
21G...D800	9	LD	800	100			
		ND	700	100			
		HD	600	100			
21G...D960	9	LD	900	100			
		ND	800	100			
		HD	700	100			
21G...D1K0	9	LD	1000	100			
		ND	900	100			
		HD	750	100			
21G...D1K2	9	LD	1100	100			
		ND	1000	100			
		HD	800	100			
21G...D1K3	9	LD	1250	100			
		ND	1100	100			
		HD	900	100			
21G...D1K4	9	LD	1350	100			
		ND	1250	100			
		HD	1000	100			
21G...D1K5	10	LD	1500	N/A			
		ND	1350	N/A			
		HD	1100	N/A			

continued on [page 60](#)

Drive Catalog Number	Frame	Duty Cycle	Hp	Short-Circuit Current Rating (kA)			
				Circuit Breaker Only (P3) ⁽¹⁾	Circuit Breaker with Input Contactor (P3 with P11) ⁽¹⁾	Molded Case Switch Only (P5) ⁽²⁾	Molded Case Switch with Input Contactor (P5 with P11) ⁽²⁾
480 Volt AC Input							
21G...D2K0	10	LD	2000	N/A			
		ND	1750	N/A			
		HD	1650	N/A			

- (1) These circuit breakers are considered Branch Circuit Protection for the unit.
- (2) No additional protection is provided with the P5 Molded Case Switch option. Branch circuit protection is required based on NEC guidelines.

600V AC Input

Drive Catalog Number	Frame	Duty Cycle	Hp	Short-Circuit Current Rating (kA)			
				Circuit Breaker Only (P3) ⁽¹⁾	Circuit Breaker with Input Contactor (P3 with P11) ⁽¹⁾	Molded Case Switch Only (P5) ⁽²⁾	Molded Case Switch with Input Contactor (P5 with P11) ⁽²⁾
600 Volt AC Input							
21G...E295	8	LD	350	50	<ul style="list-style-type: none"> • 18 w/601...700 A Class L fuse • 18 w/500 A CB • 100 w/600 A Class J fuse 	25	• 25 w/600 A Class J fuse
		ND	300	50	<ul style="list-style-type: none"> • 18 w/600 A Class L fuse • 18 w/500 A CB • 100 w/600 A Class J fuse 	25	• 25 w/600 A Class J fuse
		HD	250	50	<ul style="list-style-type: none"> • 18 w/600 A Class L fuse • 18 w/500 A CB • 100 w/600 A Class J fuse 	25	• 25 w/600 A Class J fuse
21G...E355	8	LD	400	50	<ul style="list-style-type: none"> • 18 w/601...800 A Class L fuse • 18 w/500 A CB • 100 w/600 A Class J fuse 	25	• 25 w/600 A Class J fuse
		ND	350	50	<ul style="list-style-type: none"> • 18 w/601...700 A Class L fuse • 18 w/500 A CB • 100 w/600 A Class J fuse 	25	• 25 w/600 A Class J fuse
		HD	300	50	<ul style="list-style-type: none"> • 18 w/600 A Class L fuse • 18 w/500 A CB • 100 w/600 A Class J fuse 	25	• 25 w/600 A Class J fuse
21G...E395	8	LD	450	50	<ul style="list-style-type: none"> • 30 w/601...900 A Class L fuse • 30 w/1000 A CB 	• 100 w/800 A max Class L fuse	• 30 w/800 A Class L fuse
		ND	400	50	<ul style="list-style-type: none"> • 18 w/601...800 A Class L fuse • 18 w/500 A CB • 100 w/600 A Class J fuse 	25	• 25 w/600 A Class J fuse
		HD	350	50	<ul style="list-style-type: none"> • 18 w/601...700 A Class L fuse • 18 w/500 A CB • 100 w/600 A Class J fuse 	25	• 25 w/600 A Class J fuse
21G...E435	8	LD	500	50	<ul style="list-style-type: none"> • 30 w/601...1000 A Class L fuse • 30 w/1000 A CB 	• 100 w/800 A max Class L fuse	• 30 w/800 A Class L fuse
		ND	450	50	<ul style="list-style-type: none"> • 30 w/601...900 A Class L fuse • 30 w/1000 A CB 	• 100 w/800 A max Class L fuse	• 30 w/800 A Class L fuse
		HD	350	50	<ul style="list-style-type: none"> • 18 w/601...700 A Class L fuse • 18 w/500 A CB • 100 w/600 A Class J fuse 	25	• 25 w/600 A Class J fuse
21G...E460	8	LD	500	35	<ul style="list-style-type: none"> • 30 w/601...1000 A Class L fuse • 30 w/1000 A CB 	• 100 w/800 A max Class L fuse	• 30 w/800 A Class L fuse
		ND	500	50	<ul style="list-style-type: none"> • 30 w/601...1000 A Class L fuse • 30 w/1000 A CB 	• 100 w/800 A max Class L fuse	• 30 w/800 A Class L fuse
		HD	400	50	<ul style="list-style-type: none"> • 18 w/601...800 A Class L fuse • 18 w/500 A CB • 100 w/600 A Class J fuse 	25	• 25 w/600 A Class J fuse
21G...E510	8	LD	550	35	<ul style="list-style-type: none"> • 30 w/601...1100 A Class L fuse • 30 w/1100 A CB 	• 100 w/800 A max Class L fuse	• 30 w/800 A Class L fuse
		ND	500	35	<ul style="list-style-type: none"> • 30 w/601...1000 A Class L fuse • 30 w/1000 A CB 	• 100 w/800 A max Class L fuse	• 30 w/800 A Class L fuse
		HD	450	50	<ul style="list-style-type: none"> • 30 w/601...900 A Class L fuse • 30 w/1000 A CB 	• 100 w/800 A max Class L fuse	• 30 w/800 A Class L fuse
21G...E595	9	LD	700	50			
		ND	600	50			
		HD	500	50			

continued on [page 61](#)

Drive Catalog Number	Frame	Duty Cycle	Hp	Short-Circuit Current Rating (kA)		
				Circuit Breaker Only (P3) ⁽¹⁾	Circuit Breaker with Input Contactor (P3 with P11) ⁽¹⁾	Molded Case Switch Only (P5) ⁽²⁾
600 Volt AC Input						
21G...E630	9	LD	800	50		
		ND	700	50		
		HD	600	50		
21G...E760	9	LD	900	50		
		ND	800	50		
		HD	700	50		
21G...E825	9	LD	950	50		
		ND	900	50		
		HD	750	50		
21G...E900	9	LD	1000	65		
		ND	950	50		
		HD	800	50		
21G...E980	9	LD	1100	65		
		ND	1000	65		
		HD	900	50		
21G...E1K1	10	LD	1220	N/A		
		ND	1100	N/A		
		HD	1000	N/A		
21G...E1K4	10	LD	1500	N/A		
		ND	1400	N/A		
		HD	1250	N/A		

(1) These circuit breakers are considered Branch Circuit Protection for the unit if the tap is within 10 ft of the breaker input.

(2) These are 21G, SCCR ratings with no additional protection provided. Branch circuit protection (fuse) is required based on NEC guidelines for options with P5.

690V AC Input

Drive Catalog Number	Frame	Duty Cycle	kW	Short-Circuit Current Rating (kA)		
				Circuit Breaker Only (P3) ⁽¹⁾	Circuit Breaker with Input Contactor (P3 with P11) ⁽¹⁾	Molded Case Switch Only (P5) ⁽²⁾
690 Volt AC Input						
21G...F265	8	LD	315	30	SCCR rating for 690V input contactor not available at time of publication.	SCCR rating for 690V input contactor not available at time of publication.
		ND	250	30		
		HD	200	30		
21G...F330	8	LD	355	30		
		ND	315	30		
		HD	250	30		
21G...F370	8	LD	400	30		
		ND	355	30		
		HD	300	30		
21G...F415	8	LD	450	30		
		ND	400	30		
		HD	355	30		
21G...F460	8	LD	500	25		
		ND	450	30		
		HD	375	30		
21G...F500	8	LD	530	25		
		ND	500	25		
		HD	400	30		

continued on [page 62](#)

Drive Catalog Number	Frame	Duty Cycle	kW	Short-Circuit Current Rating (kA)		
				Circuit Breaker Only (P3) ⁽¹⁾	Circuit Breaker with Input Contactor (P3 with P11) ⁽¹⁾	Molded Case Switch Only (P5) ⁽²⁾
690 Volt AC Input						
21G...F590	9	LD	630	35		
		ND	560	35		
		HD	450	35		
21G...F650	9	LD	710	35		
		ND	630	35		
		HD	500	35		
21G...F710	9	LD	800	35		
		ND	710	35		
		HD	560	35		
21G...F765	9	LD	850	35		
		ND	750	35		
		HD	630	35		
21G...F795	9	LD	900	35		
		ND	800	35		
		HD	710	35		
21G...F960	9	LD	1000	35		
		ND	900	35		
		HD	800	35		
21G...F1K0	10	LD	1100	N/A		
		ND	1000	N/A		
		HD	900	N/A		
21G...F1K4	10	LD	1500	N/A		
		ND	1400	N/A		
		HD	1120	N/A		

- (1) These circuit breakers are considered Branch Circuit Protection for the unit if the tap is within 10 ft of the breaker input.
- (2) These are 21G, SCCR ratings with no additional protection provided. Branch circuit protection (fuse) is required based on NEC guidelines for options with P5.

Cable Considerations

Power Cable Types Acceptable for 200...600 Volt Installations

A variety of cable types are acceptable for drive installations. For an in-depth discussion of cable types, including a table of maximum motor cable lengths, see the *Wiring and Grounding Guidelines for Pulse Width Modulated (PWM) AC Drives*, publication [DRIVES-IN001](#).

Recommended Cable Design

Rating/Type	Description
600V 75 °C (167 °F)	<ul style="list-style-type: none"> Four tinned copper conductors with XLPE insulation. Copper braid/aluminum foil combination shield and tinned copper drain wire. PVC jacket.

Wiring Considerations

Type		Wire Type(s)	Description	Min. Insulation Rating
Power (1) (2)	Standard	–	<ul style="list-style-type: none"> Four tinned copper conductors with XLPE insulation. Copper braid/aluminum foil combination shield and tinned copper drain wire. PVC jacket. 	600V, 75 °C (167 °F)
	Standard Analog I/O	–	0.750 mm ² (18 AWG), twisted pair, 100% shield w/drain.	300V, 75...90 °C (167...194 °F)
Signal (1) (3) (4)	Remote Pot	–	0.750 mm ² (18 AWG), 3 conductor, shielded.	
	Encoder/ Pulse I/O < 30 m (100 ft)	Combined	0.196 mm ² (24 AWG) individually shielded pairs.	
	Encoder/ Pulse I/O 30 to 152 m (100 to 500 ft)	Signal	0.196 mm ² (24 AWG) individually shielded pairs.	
		Power	0.750 mm ² (18 AWG) in. individually shielded pairs	
		Combined	0.330 mm ² (22 AWG), power is 0.500 mm ² (20 AWG) individually shielded pairs.	
	Encoder/ Pulse I/O 152 to 259 m (500 to 850 ft)	Signal	0.196 mm ² (24 AWG) individually shielded pairs.	
Power		0.750 mm ² (18 AWG) individually shielded pairs.		
Combined		0.750 mm ² (18 AWG) individually shielded pairs.		
Digital I/O Safety Inputs Homing Inputs (1) (3) (4)	Un-shielded	–	Per US NEC or applicable national or local code.	300V, 60 °C (140 °F)
	Shielded	Multi-conductor shielded cable	0.750 mm ² (18 AWG), 3 conductor, shielded.	

(1) Control and signal wires must be separated from power wires by at least 0.3 meters (1 foot).

(2) The use of shielded wire for AC input power may not be necessary but is always recommended.

(3) If the wires are short and contained within a cabinet that has no sensitive circuits, the use of shielded wire may not be necessary, but is always recommended.

(4) I/O terminals labeled “(–)” or “Common” are not referenced to earth ground and are designed to greatly reduce common mode interference. Grounding these terminals can cause signal noise. For CE installations, 115V I/O must use shielded cable or have a cable length less than 30 m (98 ft).

Power Wiring Options

The following table describes the cabling options available for each frame 8...10 drive enclosure. See pages [89...114](#) for conduit plate dimensions.

<div style="background-color: #cccccc; width: 40px; height: 15px; margin: 0 auto;"></div> <p>Adequate Spacing Available conduit plates provide adequate spacing for typical cabling.</p>	<div style="background-color: #cccccc; width: 40px; height: 15px; margin: 0 auto; text-align: center;">0</div> <p>Possible – Evaluation is Required Available conduit plates must be evaluated to determine if cabling fits.</p>	<div style="background-color: #cccccc; width: 40px; height: 15px; margin: 0 auto; text-align: center;">X</div> <p>Not Possible – Insufficient Spacing Conduit plates are not available for the specified configuration.</p>
---	---	--

Frame	Enclosure Rating	Enclosure Code	Cabinet Layout	Top Entry/ Top Exit	Top Entry/ Bottom Exit	Bottom Entry/ Top Exit	Bottom Entry/ Bottom Exit
8	IP20, NEMA/UL Type 1	B	600 mm Drive Cabinet	X		X	0
		L, P, W	800 mm Drive Cabinet	0		0	
		B	600 mm Drive with Power Option Bay			X	0
		L, P, W	800 mm Drive with Power Option Bay			0	
		B	600 mm Drive with Wiring Bay				
		L, P, W	800 mm Drive with Wiring Bay				
		B	600 mm Drive with Power Option and Wiring Bays				
		L, P, W	800 mm Drive with Power Option Bay and Wiring Bays				
	IP54, NEMA 12	J, K, Y	800 mm Drive Cabinet	X	X	X	
		J, K, Y	800 mm Drive with Power Option Bay	X		0	0
		J, K, Y	800 mm Drive with Wiring Bay				
		J, K, Y	800 mm Drive with Power Option Bay and Wiring Bays				
9	IP20, NEMA/UL Type 1	B	600 mm Drive Cabinet	0		0	0
		L, P, W	800 mm Drive Cabinet				
		B	600 mm Drive with Power Option Bay			X	
		L, P, W	800 mm Drive with Power Option Bay			0	
		B	600 mm Drive with Wiring Bay				
		L, P, W	800 mm Drive with Wiring Bay				
		B	600 mm Drive with Power Option and Wiring Bays				
		L, P, W	800 mm Drive with Power Option Bay and Wiring Bays				
	IP54, NEMA 12	J, K, Y	800 mm Drive Cabinet	X	X	X	
		J, K, Y	800 mm Drive with Power Option Bay	0		0	
		J, K, Y	800 mm Drive with Wiring Bay				
		J, K, Y	800 mm Drive with Power Option Bay and Wiring Bays				
10	IP20, NEMA/UL Type 1	B	600 mm Drive Cabinet	0		0	0
		L, P, W	800 mm Drive Cabinet			0	
		B	600 mm Drive with Power Option Bay	X		X	
		L, P, W	800 mm Drive with Power Option Bay	0		0	
		B	600 mm Drive with Wiring Bay				
		L, P, W	800 mm Drive with Wiring Bay				
		B	600 mm Drive with Power Option and Wiring Bays				
		L, P, W	800 mm Drive with Power Option Bay and Wiring Bays			X	
	IP54, NEMA 12	J, K, Y	800 mm Drive Cabinet	X	X	X	
		J, K, Y	800 mm Drive with Power Option Bay	X	0	0	
		J, K, Y	800 mm Drive with Wiring Bay	0			
		J, K, Y	800 mm Drive with Power Option Bay and Wiring Bays				

Motor Considerations

Due to the operational characteristics of AC variable frequency drives, motors with inverter grade insulation systems designed to meet or exceed NEMA MG1 Part 31.40.4.2 standards for resistance to spikes of 1600 volts are recommended.

Guidelines must be followed when using non-inverter grade motors to avoid premature motor failures. See Wiring and Grounding Guidelines for Pulse Width Modulated (PWM) AC Drives, publication [DRIVES-IN001](#) for recommendations.

Allen-Bradley Permanent Magnet Servo Motors

When using a PowerFlex 755 to control a permanent magnet motor, the motor feedback device must have a resolution such that the number of pulses per revolution (PPR) is an exponent of 2 (for example: 512, 1024, 2048, 4096, 8192 and so on).

The following table contains a list of specifications for Allen-Bradley servo motors compatible with PowerFlex 750-Series drives. This list primarily includes 460V rated MP-Series™ and 1326AB/1326AS servo motors. This information is provided to help configure a PowerFlex 750-Series drive with the appropriate servo motor data. For information regarding compatibility and configuration of Allen-Bradley servo motors (including Bulletin RDB or RDD-Series™ Direct Drive Motors) and third-party PM motors not listed here, contact Allen-Bradley Drives Technical Support.

Model Number	Motor NP Volts (line-line V rms)	Motor NP Amps (A rms)	Motor NP Hertz (Hz)	Motor NP RPM (oper. rpm)	Motor NP Power (kW)	Motor Poles	Current peak (A rms)	System Cont. Stall Torque (N·m)	Motor Max RPM
MPL-B4530K	460	7.8	200.7	3010	2.6	8	19.1	8.25	4000
MPL-B4560F	460	8.3	144.7	2170	3.2	8	25.5	14.1	3000
MPL-B520K	460	8.1	208	3120	3.5	8	23.3	10.7	4000
MPL-B540K	460	14.5	177.3	2660	5.4	8	42.4	19.4	4000
MPL-B560F	460	14.5	130.7	1960	5.5	8	42.4	26.8	3000
MPL-B580F	460	18.4	132.7	1990	7.1	8	66.5	34	3000
MPL-B580J	460	22.6	148	2220	7.9	8	66.5	34	3800
MPL-B640F	460	22.7	106	1590	6.11	8	46	36.7	3000
MPL-B660F	460	27.2	81.3	1220	6.15	8	67.9	48	3000
MPL-B680D	460	24	94	1410	9.3	8	66.5	62.8	2000
MPL-B680F	460	33.9	79.3	1190	7.5	8	67.9	60	3000
MPL-B860D	460	33.6	96	1440	12.5	8	67.5	83.1	2000
MPL-B880C	460	33.6	72.7	1090	12.6	8	69	110	1500
MPL-B880D	460	40.3	86.7	1300	15	8	113.2	110	2000
MPL-B960B	460	29.7	62	930	12.7	8	63.6	130	1200
MPL-B960C	460	38.9	76	1140	14.8	8	88.4	124.3	1500
MPL-B960D	460	50.2	76.7	1150	15	8	102.5	124.3	2000
MPL-B980B	460	31.8	59.3	890	15.02	8	70.7	162.7	1000
MPL-B980C	460	48.2	67.3	1010	16.8	8	99	158.2	1500
MPL-B980D	460	63.6	74.7	1120	18.6	8	141.4	158.2	2000
MPM-B1151F	480	1.5	266.7	4000	0.75	8	7	2.18	5000
MPM-B1151T	480	3.1	333.3	5000	0.9	8	14.5	2.18	7000

Model Number	Motor NP Volts (line-line V rms)	Motor NP Amps (A rms)	Motor NP Hertz (Hz)	Motor NP RPM (oper. rpm)	Motor NP Power (kW)	Motor Poles	Current peak (A rms)	System Cont. Stall Torque (N·m)	Motor Max RPM
MPM-B1152C	480	2.3	166.7	2500	1.2	8	8.8	2.18	3000
MPM-B1152F	480	2.9	266.7	4000	1.4	8	15.5	4.74	5200
MPM-B1152T	480	5.2	266.7	4000	1.4	8	26.8	4.74	7000
MPM-B1153E	480	2.7	200	3000	1.4	8	15.3	6.55	3500
MPM-B1153F	480	3.2	266.7	4000	1.45	8	22.6	6.55	5500
MPM-B1153T	480	5.5	266.7	4000	1.45	8	39.2	6.55	7000
MPM-B1302F	480	3.4	266.7	4000	1.65	8	15.6	5.99	4500
MPM-B1302M	480	4.9	266.7	4000	1.65	8	22.6	5.99	6000
MPM-B1302T	480	6.6	266.7	4000	1.65	8	30.7	5.99	7000
MPM-B1304C	480	3.4	183.3	2750	2	8	15.8	10.2	2750
MPM-B1304E	480	4.1	166.7	2500	2.2	8	24.2	10.2	4000
MPM-B1304M	480	7.3	233.3	3500	2.2	8	42.9	10.2	6000
MPM-B1651C	480	4.7	200	3000	2.5	8	20.6	10.7	3500
MPM-B1651F	480	8.2	200	3000	2.5	8	36	10.7	5000
MPM-B1651M	480	10.9	200	3000	2.5	8	40.2	10.7	5000
MPM-B1652C	480	7	166.7	2500	3.8	8	23.8	16	2500
MPM-B1652E	480	8	233.3	3500	4.3	8	42.8	19.4	3500
MPM-B1652F	480	11	233.3	3500	4.3	8	59.5	19.4	4500
MPM-B1653C	480	10.5	133.3	2000	4.6	8	41.9	26.8	2500
MPM-B1653E	480	10.2	200	3000	5.1	8	51.6	26.8	3500
MPM-B1653F	480	13.2	200	3000	5.1	8	66.7	26.8	4000
MPM-B2152C	480	12.3	133.3	2000	5.6	8	39.2	36.7	2500
MPM-B2152F	480	18.7	166.7	2500	5.9	8	69.3	33	4500
MPM-B2152M	480	21	166.7	2500	5.9	8	54	30	5000
MPM-B2153B	480	12.7	116.7	1750	6.8	8	42.4	48	2000
MPM-B2153E	480	19.3	133.3	2000	7.2	8	69.7	48	3000
MPM-B2153F	480	22.1	133.3	2000	7.2	8	69.6	45	3800
MPM-B2154B	480	13.9	116.7	1750	6.9	8	69.3	62.8	2000
MPM-B2154e	480	18.3	133.3	2000	7.5	8	69.5	56	3000
MPM-B2154F	480	19.8	133.3	2000	7.5	8	59.3	56	3300
1326AB-B515G ⁽¹⁾	460	9.5	88.7	2660	2.9	4	28.5	10.4	5000
1326AB-B520F ⁽¹⁾	460	8.8	70.3	2110	2.9	4	26.4	13.1	3500
1326AB-B530E ⁽¹⁾	460	9.5	74.3	2230	4.2	4	28.5	18	3000
1326AB-B720E ⁽¹⁾	460	17.5	70	2100	6.8	4	52.5	30.9	3500
1326AB-B720F ⁽¹⁾	460	27.5	117	3510	11.7	4	66.5	31.8	5000
1326AB-B730E ⁽¹⁾	460	22.8	78.3	2350	9.6	4	66.5	39	3350
1326AB-B740C ⁽¹⁾	460	20.9	52.3	1570	8.7	4	62.7	53	2200
1326AB-B740E ⁽¹⁾	460	32	79.7	2390	12.7	4	66.5	50.8	3400
MPG-B050-031 ⁽²⁾	460	16.3	92	920	1.2	12	32.5	12.4	2510

Model Number	Motor NP Volts (line-line V rms)	Motor NP Amps (A rms)	Motor NP Hertz (Hz)	Motor NP RPM (oper. rpm)	Motor NP Power (kW)	Motor Poles	Current peak (A rms)	System Cont. Stall Torque (N·m)	Motor Max RPM
MPG-B110-031 ⁽²⁾	460	12.9	112	1120	2	12	31.1	17	2420
MPG-B110-091 ⁽²⁾	460	10.6	184	1840	1.6	12	20.5	8.3	3500
1326AS-B630F ⁽²⁾	460	7.8	142.7	2140	2.4	8	18.5	10.7	4500
1326AS-B660E ⁽²⁾	460	11.8	100.7	1510	3.4	8	29.8	21.5	3000
1326AS-B690E ⁽²⁾	460	19	87.3	1310	5	8	41.3	36.4	3000
1326AS-B840E ⁽²⁾	460	21.2	79.3	1190	4.7	8	39.5	37.6	3000
1326AS-B860C ⁽²⁾	460	17.6	77.3	1160	6	8	44.4	49.3	2000

(1) 1326AB-series motors are being replaced by MPM-series motors. They are available for a limited time. Do not specify for new projects.

(2) 1326AS and MPG-series motors are no longer available. Do not specify for new projects.

For motor power and feedback cable information, see the Kinetix Motion Control Selection Guide (publication [GMC-SG001](#)).

Dimensions and Weights

Frame/Rating Cross-reference

400/480V AC

Catalog Number	Light Duty kW Output	Normal Duty kW Output	Heavy Duty kW Output	Catalog Number	Light Duty Hp Output	Normal Duty Hp Output	Heavy Duty Hp Output	Enclosure Code/Frame Size					
								B, J, L, T	F	G	N	K, P, W, Y	R
400 Volt				480 Volt									
20x...C2P1	–	0.75	0.75	20x...D2P1	–	1	1	–	2	2	2	–	1
20x...C3P5	–	1.5	1.5	20x...D3P4	–	2	2						
20x...C5P0	–	2.2	2.2	20x...D5P0	–	3	3						
20x...C8P7	–	4	4	20x...D8P0	–	5	5						
20x...C011	–	5.5	5.5	20x...D011	–	7.5	7.5						
20x...C015	–	7.5	5.5	20x...D014	–	10	7.5						
20x...C022	–	11	7.5	20x...D022	–	15	10						
20x...C030	–	15	11	20x...D027	–	20	15		3	3	3		
20x...C037	–	18.5	15	20x...D034	–	25	20						
20x...C043	–	22	18.5	20x...D040	–	30	25						
20x...C060	–	30	22	20x...D052	–	40	30		4	4	4		
20x...C072	–	37	30	20x...D065	–	50	40			5			
20x...C085	–	45	37	20x...D077	–	60	50		5		5		
20x...C104	–	55	45	20x...D096	–	75	60			6			
20x...C140	–	75	55	20x...D125	–	100	75		(1)		6		
20x...C170	–	90	75	20x...D156	–	125	100						
20x...C205	–	110	90	20x...D186	–	150	125						
20x...C260	–	132	110	20x...D248	–	200	150			7			
20x...C302	–	160	132	20x...D302	–	250	200				7		
20x...C367	–	200	160	20x...D361	–	300	250						
20x...C456	–	250	200	20x...D415	–	350	300						
2xG...C460	315	250	200	20x...D430	400	350	300	8	–	–	–	8	
2xG...C477	–	270	200	20x...D477	–	400	300	–	(1)	–	7	–	
2xG...C540	315	315	250	20x...D485	450	400	350	8	–	–	–	8	
2xG...C567	355	315	250	20x...D545	500	450	350						
2xG...C650	400	355	315	20x...D617	600	500	400						
2xG...C750	450	400	355	20x...D710	650	600	450						
2xG...C770	450	400	355	20x...D740	700	650	500						
2xG...C910	560	500	400	20x...D800	800	700	600	9				9	
2xG...C1K0	630	560	500	20x...D960	900	800	700						
2xG...C1K1	710	630	500	20x...D1K0	1000	900	750						
2xG...C1K2	800	710	560	20x...D1K2	1100	1000	800						
2xG...C1K4	850	800	630	20x...D1K3	1250	1100	900						
2xG...C1K5	900	850	710	20x...D1K4	1350	1250	1000						
2xG...C1K6	1000	900	710	20x...D1K5	1500	1350	1100	10				10	
2xG...C2K1	1400	1250	1000	20x...D2K0	2000	1750	1650						

(1) For frames 6 and 7 a user installed Flange kit (20-750-FLNG4-Fx) is available to convert a Code N drive that provides a NEMA/UL Type 4X/12 back.

600/690V AC

Catalog Number	Light Duty kW Output	Normal Duty kW Output	Heavy Duty kW Output	Catalog Number	Light Duty Hp Output	Normal Duty Hp Output	Heavy Duty Hp Output	Enclosure Code/Frame Size						
								B, J, L, T	F		G, N		K, P, W, Y	R
									690V	600V	690V	600V		
690 Volt				600 Volt										
				20x...E1P7	–	1	0.5	–	–	3	–	3	–	–
				20x...E2P7	–	2	1							
				20x...E3P9	–	3	2							
				20x...E6P1	–	5	3							
				20x...E9P0	–	7.5	5							
				20x...E011	–	10	7.5							
20x...F012	–	7.5	5.5	20x...E012	–	10	7.5			–	6	6		
				20x...E017	–	15	10			3	–	3		
20x...F015	–	11	7.5	20x...E018	–	15	10			–	6	6		
				20x...E022	–	20	15			3	–	3		
20x...F020	–	15	11	20x...E023	–	20	15			–	6	6		
20x...F023	–	18.5	15	20x...E024	–	20	20			–	6	6		
				20x...E027	–	25	20			4	–	4		
20x...F030	–	22	18.5	20x...E028	–	25	20			–	6	6		
				20x...E032	–	30	25			4	–	4		
20x...F034	–	30	22	20x...E033	–	30	25			–	6	6		
				20x...E041	–	40	30			5	–	5		
20x...F046	–	37	30	20x...E042	–	40	30			–	6	6		
				20x...E052	–	50	40			5	–	5		
20x...F050	–	45	37	20x...E053	–	50	40			–	6	6		
20x...F061	–	55	45	20x...E063	–	60	50							
20x...F082	–	75	55	20x...E077	–	75	60							
20x...F098	–	90	75	20x...E099	–	100	75							
20x...F119	–	110	90	20x...E125	–	125	100							
20x...F142	–	132	110	20x...E144	–	150	125							
20x...F171	–	160	132	20x...E192	–	200	150							
20x...F212	–	200	160	20x...E242	–	250	200							
20x...F263	–	250	200	20x...E289	–	300	250							
2xG...F265	315	250	200	20x...E295	350	300	250	8						
2xG...F330	355	315	250	20x...E355	400	350	300							
2xG...F370	400	355	300	20x...E395	450	400	350							
2xG...F415	450	400	355	20x...E435	500	450	350							
2xG...F460	500	450	375	20x...E460	500	500	400							
2xG...F500	530	500	400	20x...E510	550	500	450							
2xG...F590	630	560	450	20x...E595	700	600	500	9						
2xG...F650	710	630	500	20x...E630	800	700	600							
2xG...F710	800	710	560	20x...E760	900	800	700							
2xG...F765	850	750	630	20x...E825	950	900	750							
2xG...F795	900	800	710	20x...E900	1000	950	800							
2xG...F960	1000	900	800	20x...E980	1100	1000	900							
2xG...F1K0	1100	1000	900	20x...E1K1	1200	1100	1000	10						10
2xG...F1K4	1500	1400	1120	20x...E1K4	1500	1400	1250							

Enclosure Options

IMPORTANT IP00, IP20, and NEMA/UL Open Type PowerFlex 750-Series drives must be mounted in a clean, dry location. Contaminants such as oils, corrosive vapors and abrasive debris must be kept out of the enclosure. These enclosures are intended for indoor use primarily to provide a degree of protection against contact with enclosed equipment. These enclosures offer no protection against airborne contaminants. See the following tables for an explanation of enclosure options and the environmental specifications found on [page 7](#).

Pollution Degree Ratings According to EN 61800-5-1

Pollution Degree	Description
1	No pollution or only dry, non-conductive pollution occurs. The pollution has no influence.
2	Normally, only non-conductive pollution occurs. Occasionally, however, a temporary conductivity caused by condensation is to be expected, when the drive is out of operation.
3	Conductive pollution or dry non-conductive pollution occurs, which becomes conductive due to condensation, which is to be expected.
4	The pollution generates persistent conductivity caused, for example by conductive dust or rain or snow.

Drive Enclosure Ratings

Frames	Enclosure Type (Cat. No. Position 6)	Installed Accessory Kit	Front Side Rating		Back Side/Heat Sink Rating	
			Enclosure Type	Pollution Degree	Enclosure Type	Pollution Degree
1	R	None	IP20, NEMA/UL Open Type	1, 2	IP20, NEMA/UL Open Type	1, 2
		NEMA Type 1	IP20, NEMA/UL Type 1	1, 2	IP20, NEMA/UL Type 1	1, 2
2...5	N	None	IP20, NEMA/UL Open Type	1, 2	IP20, NEMA/UL Open Type	1, 2
		NEMA Type 1	IP20, NEMA/UL Type 1	1, 2	IP20, NEMA/UL Type 1	1, 2
		Flange	IP20, NEMA/UL Type 1	1, 2	IP20, NEMA/UL Type 1	1, 2
	F	None	IP20, NEMA/UL Open Type	1, 2	IP66, NEMA/UL Type 4X	1, 2, 3, 4
	G	None	IP54, NEMA/UL Type 12	1, 2, 3, 4	IP54, NEMA/UL Type 12	1, 2, 3, 4
6 and 7	N	None	IP00, NEMA/UL Open Type	1, 2	IP00, NEMA/UL Open Type Kit	1, 2
		NEMA Type 1	IP20, NEMA/UL Type 1	1, 2	IP20, NEMA/UL Type 1	1, 2
		NEMA Type 4X Flange	IP00, NEMA/UL Open Type	1, 2	IP66, NEMA/UL Type 4X	1, 2, 3, 4
	G	None	IP54, NEMA/UL Type 12	1, 2, 3, 4	IP54, NEMA/UL Type 12	1, 2, 3, 4
8...10	B, L, P, W	None	IP20, NEMA/UL Type 1, MCC	1, 2	IP20, NEMA/UL Type 1	1, 2
	J, K, Y	None	IP54, NEMA 12	1, 2, 3, 4	IP54, NEMA 12	1, 2, 3, 4

Minimum Mounting Clearances

Specified vertical clearance requirements (indicated below) are intended to be from the drive to the closest object that can restrict airflow through the drive heat sink and chassis. The drive must be mounted in a vertical orientation as shown and must make full contact with the mounting surface. Do not use standoffs or spacers. In addition, inlet air temperature must not exceed the product specification.

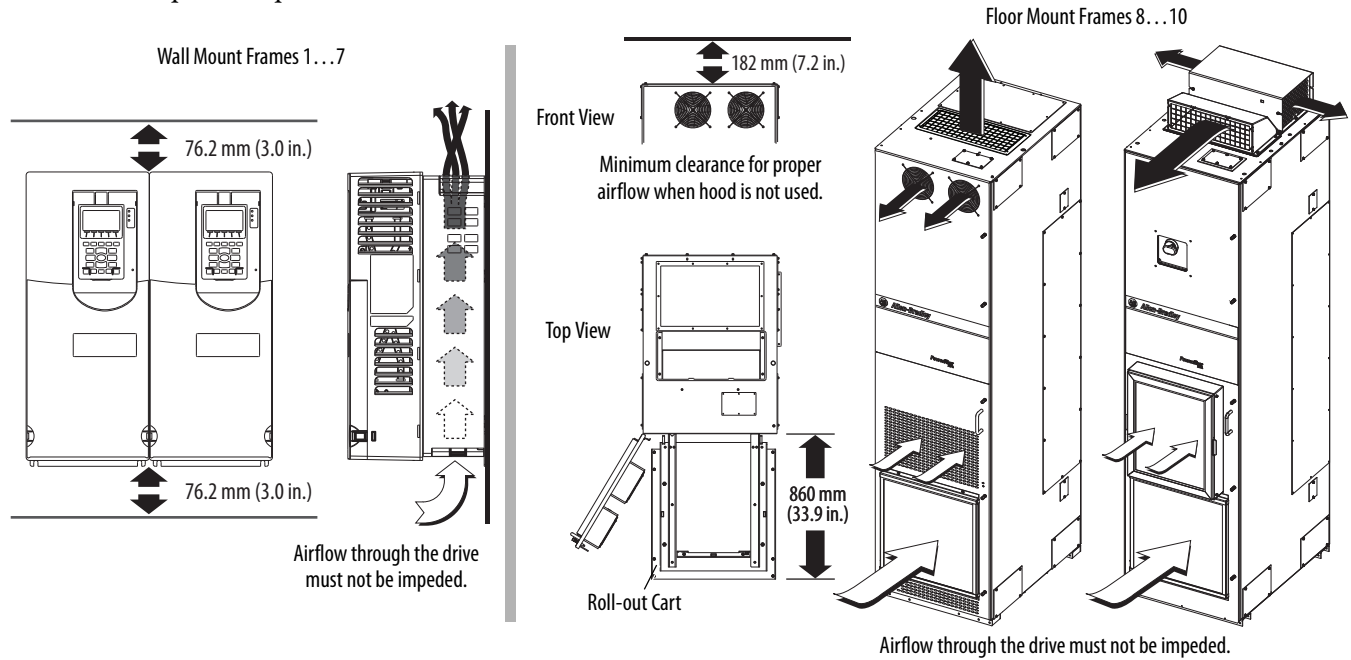

Approximate Weights

Drive	Frame Size	Drive Rating		Enclosure Code/Weight <i>kg (lb)</i>				
		kW (400V, 690V)	Hp (480V, 600V)	F	GN		R	
Standard (20F, 20G)	AC Input and Common DC Input	1	0.75...7.5	1...10				6 (13)
		2	0.75...11	1...15	8 (17)	8 (17)	8 (17)	
		3	15...22	0.5...30	12 (26)	12 (26)	12 (26)	
		4	30...37	20...50	14 (30)	14 (30)	14 (30)	
		5	45...55	30...70	20 (45)	20 (45)	20 (45)	
		6	5.5...7.5	7.5...100	37 (82)	89 (197)	37 (82)	
			45...132	50...200	38 (84)	91 (200)	39 (85)	
7	132...200	150...300	69 (152)	135 (297)	79 (174)			
	200...270	300...400	96 (212)	162 (357)	106 (234)			
				B, L	P, W	J	K, Y	
Standard (20G)	AC Input	8	250...400	350...650	623 (1374)	1145 (2525)	644 (1419)	1166 (2570)
		9	500...850	700...1250	1246 (2748)	2290 (5051)	1287 (2838)	2332 (5141)
		10	900...1250	1350...1750	1869 (4122)	3435 (7576)	1931 (4257)	3498 (7711)
	Common DC Input	8	250...400	350...650	566 (1248)	1088 (2400)	586 (1293)	1109 (2445)
		9	500...850	700...1250	1132 (2497)	2176 (4799)	1173 (2587)	2218 (4889)
		10	900...1250	1350...1750	1698 (3745)	3264 (7199)	1760 (3880)	3327 (7334)
with Options (21G)	AC Input	8	250...400	350...650	1145 (2525)	1675 (3694)	1166 (2570)	1696 (3739)
		9	500...850	700...1250	1730 (3815)	2820 (6219)	1771 (3905)	2862 (6309)
		10	900...1250	1350...1750	2315 (5106)	3965 (8745)	2377 (5241)	4028 (8880)

Maximum Component Weights - Frames 8...10

Component	AC Input - <i>kg (lb)</i>	Common DC Input - <i>kg (lb)</i>
Converter/DC Input w/Precharge	64 (140)	64 (140)
Inverter	222 (490)	165 (363)
Drive Assembly (Open, IP00)	286 (630)	229 (504)

Approximate Dimensions

Dimension Drawing Index

Frame	Description	Page
1	IP20, NEMA/UL Type Open	73
2	IP20, NEMA/UL Type Open	73
	Flange Mount	74
	IP54, NEMA/UL Type 12	75
3	IP20, NEMA/UL Open Type	75
	Flange Mount	76
	IP54, NEMA/UL Type 12	77
4	IP20, NEMA/UL Open Type	77
	Flange Mount	78
	IP54, NEMA/UL Type 12	79
5	IP20, NEMA/UL Open Type	79
	Flange Mount	80
	IP54, NEMA/UL Type 12	81
6	IP00, NEMA/UL Open Type	82
	Flange Mount	83
	IP54, NEMA/UL Type 12	84
7	IP00, NEMA/UL Open Type	85
	Flange Mount	86
	NEMA/UL Type 1	87
	IP54, NEMA/UL Type 12	88
8	MCC Style Cabinet, 600 mm (23.6 in.) Deep - IP20	89
	MCC Style Cabinet with Wiring Bay, 600 mm (23.6 in.) Deep - IP20	90
	MCC Style Cabinet with Cabinet Option Bay, 600 mm (23.6 in.) Deep - IP20	91
	MCC Style Cabinet with Wiring Bay and Cabinet Option Bay, 600 mm (23.6 in.) Deep - IP20	92
	MCC Style Cabinet, 800 mm (31.5 in.) Deep - IP20	93
	MCC Style Cabinet with Wiring Bay, 800 mm (31.5 in.) Deep - IP20	94
	MCC Style Cabinet with Cabinet Option Bay, 800 mm (31.5 in.) Deep - IP20	95
	MCC Style Cabinet with Wiring Bay and Cabinet Option Bay, 800 mm (31.5 in.) Deep - IP20	96
	MCC Style Cabinet, 800 mm (31.5 in.) Deep - IP54	97
	MCC Style Cabinet with Wiring Bay, 800 mm (31.5 in.) Deep - IP54	98
	MCC Style Cabinet with Cabinet Option Bay, 800 mm (31.5 in.) Deep - IP54	99
	MCC Style Cabinet with Wiring Bay and Cabinet Option Bay, 800 mm (31.5 in.) Deep - IP54	100
	Open Style - AC Input	101
	Open Style - DC Input	102
9	MCC Style Cabinet, 600 mm (23.6 in.) Deep - IP20	103
	MCC Style Cabinet with Wiring Bay, 600 mm (23.6 in.) Deep - IP20	104
	MCC Style Cabinet with Cabinet Option Bay, 600 mm (23.6 in.) Deep - IP20	105
	MCC Style Cabinet with Cabinet Option Bay and Wiring Bay, 600 mm (23.6 in.) Deep - IP20	106
	MCC Style Cabinet, 800 mm (31.5 in.) Deep - IP20	107
	MCC Style Cabinet with Wiring Bay, 800 mm (31.5 in.) Deep - IP20	108
	MCC Style Cabinet with Cabinet Option Bay, 800 mm (31.5 in.) Deep - IP20	109
	MCC Style Cabinet with Cabinet Option Bay and Wiring Bay, 800 mm (31.5 in.) Deep - IP20	110
	MCC Style Cabinet, 800 mm (31.5 in.) Deep - IP54	111
	MCC Style Cabinet with Wiring Bay, 800 mm (31.5 in.) Deep - IP54	112
	MCC Style Cabinet with Cabinet Option Bay, 800 mm (31.5 in.) Deep - IP54	113
	MCC Style Cabinet with Cabinet Option Bay and Wiring Bay, 800 mm (31.5 in.) Deep - IP54	114
	Open Style - AC Input	115
	Open Style - DC Input	116

Frame	Description	Page
10	MCC Style Cabinet, 600 mm (23.6 in.) Deep - IP20	117
	MCC Style Cabinet, 800 mm (31.5 in.) Deep - IP20	118
	MCC Style Cabinet 800 mm (31.5 in.) Deep - IP54	119
	Open Style - AC Input	120
	Open Style - DC Input	121
1...6	NEMA/UL Type 1 Kit	122
1...5	NEMA/UL Type 1 Bottom View	123
1...5	EMC Plate and Cores Kit	124

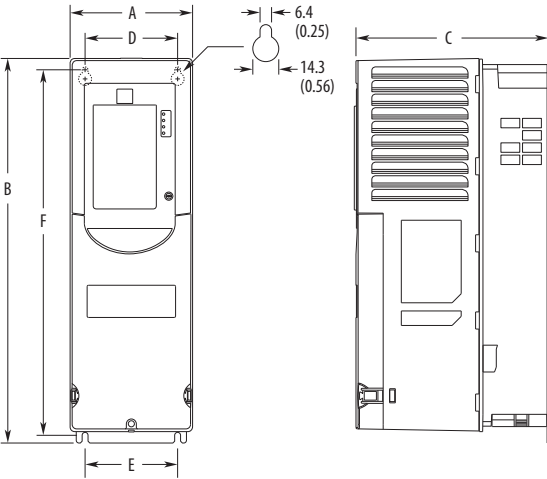
Frame	Type	Approximate Dimensions – mm (in.)																									
1,2	IP20, NEMA/UL Type Open		<p>Frame 2 Shown</p> <table border="1"> <thead> <tr> <th>Frame</th> <th>A</th> <th>B</th> <th>C</th> <th>D</th> <th>E</th> <th>F</th> <th>Weight kg (lb)</th> </tr> </thead> <tbody> <tr> <td>1</td> <td>110.0 (4.33)</td> <td>400.5 (15.77)</td> <td>211.0 (8.31)</td> <td>68.0 (2.68)</td> <td>82.0 (3.23)</td> <td>390.4 (15.37)</td> <td>6.0 (12.75)</td> </tr> <tr> <td>2</td> <td>134.5 (5.30)</td> <td>424.2 (16.70)</td> <td>212.0 (8.35)</td> <td>100.0 (3.94)</td> <td>100.0 (3.94)</td> <td>404.2 (15.91)</td> <td>7.8 (17.2)</td> </tr> </tbody> </table>	Frame	A	B	C	D	E	F	Weight kg (lb)	1	110.0 (4.33)	400.5 (15.77)	211.0 (8.31)	68.0 (2.68)	82.0 (3.23)	390.4 (15.37)	6.0 (12.75)	2	134.5 (5.30)	424.2 (16.70)	212.0 (8.35)	100.0 (3.94)	100.0 (3.94)	404.2 (15.91)	7.8 (17.2)
Frame	A	B	C	D	E	F	Weight kg (lb)																				
1	110.0 (4.33)	400.5 (15.77)	211.0 (8.31)	68.0 (2.68)	82.0 (3.23)	390.4 (15.37)	6.0 (12.75)																				
2	134.5 (5.30)	424.2 (16.70)	212.0 (8.35)	100.0 (3.94)	100.0 (3.94)	404.2 (15.91)	7.8 (17.2)																				

Frame	Type	Approximate Dimensions – mm (in.)
-------	------	-----------------------------------

2 Flange Mount

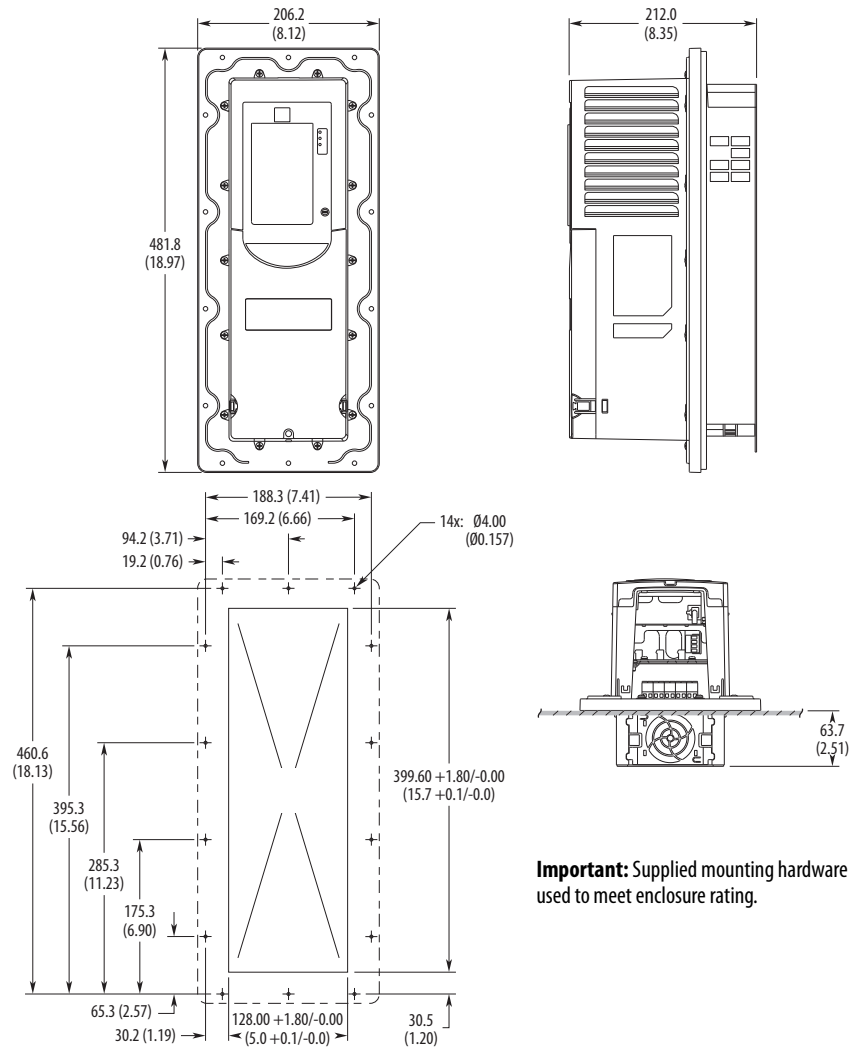

Important: Supplied mounting hardware must be used to meet enclosure rating.

Frame	Type	Approximate Dimensions – mm (in.)
-------	------	-----------------------------------

2 IP54,
NEMA/UL Type 12

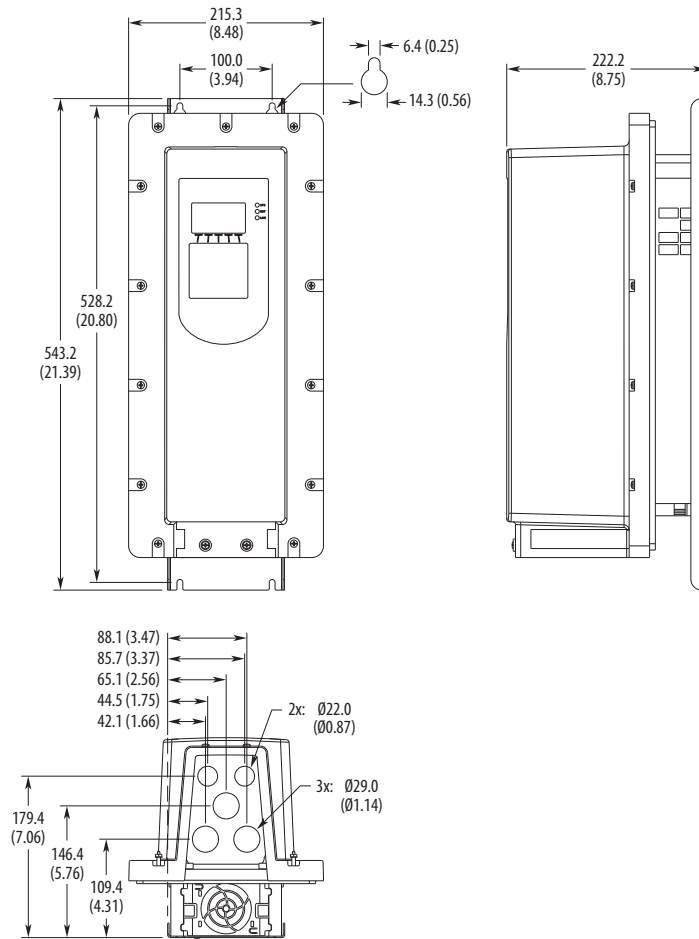

3 IP20,
NEMA/UL Open Type

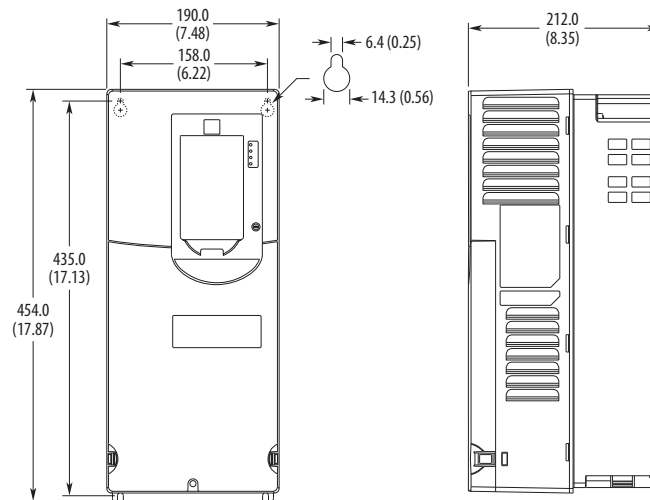

Frame	Type	Approximate Dimensions – mm (in.)
3	Flange Mount	

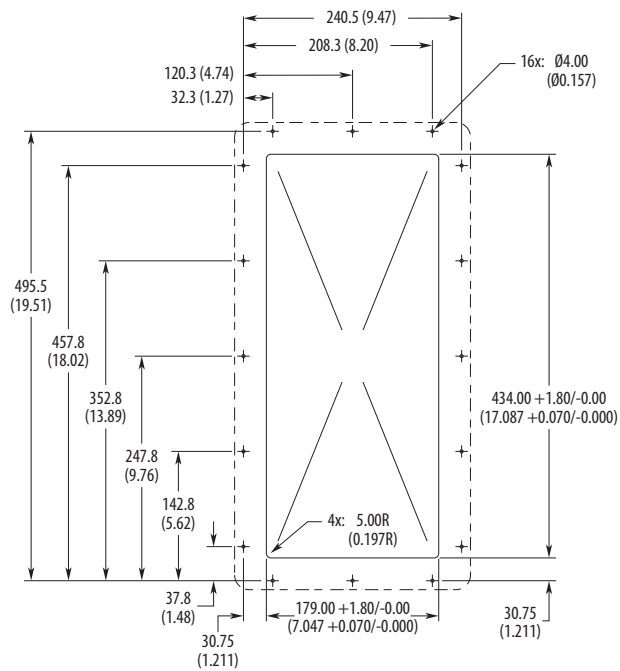
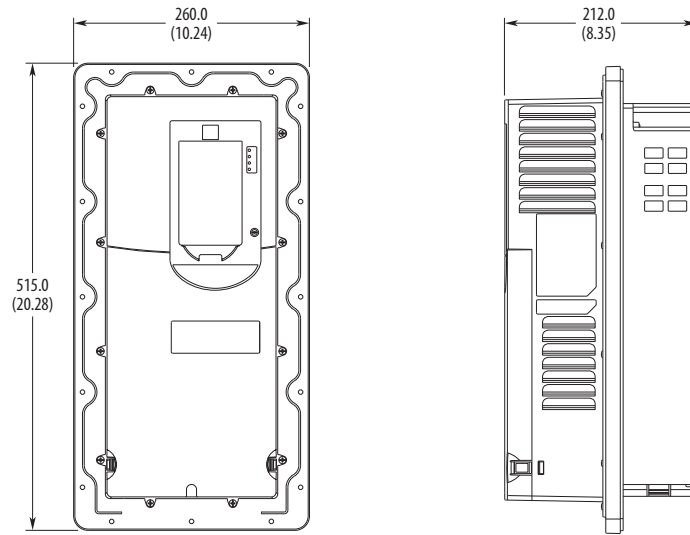

Important: Supplied mounting hardware must be used to meet enclosure rating.

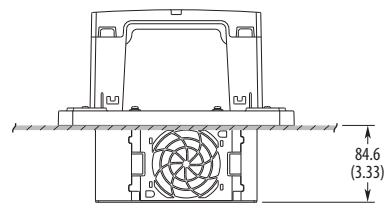

Frame	Type	Approximate Dimensions – mm (in.)
-------	------	-----------------------------------

3 IP54,
NEMA/UL Type 12

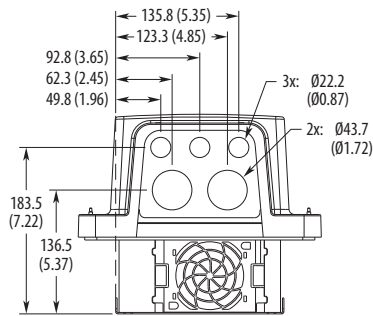
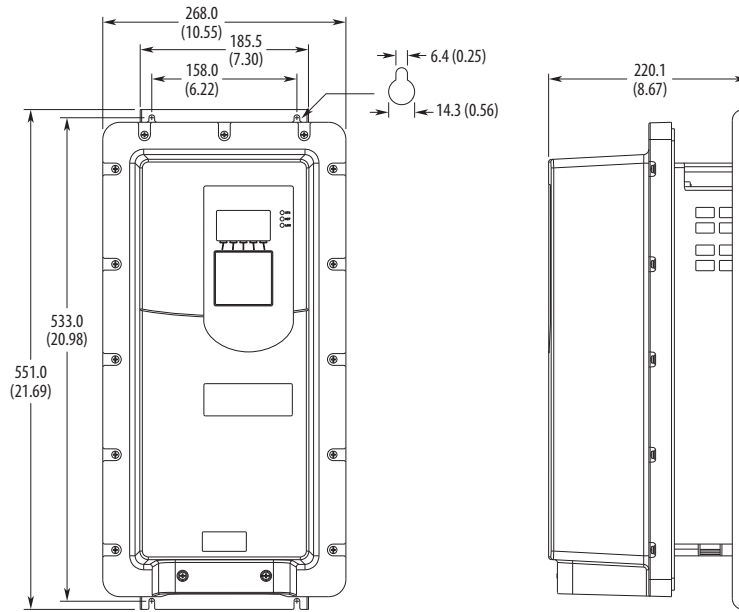

4 IP20,
NEMA/UL Open Type

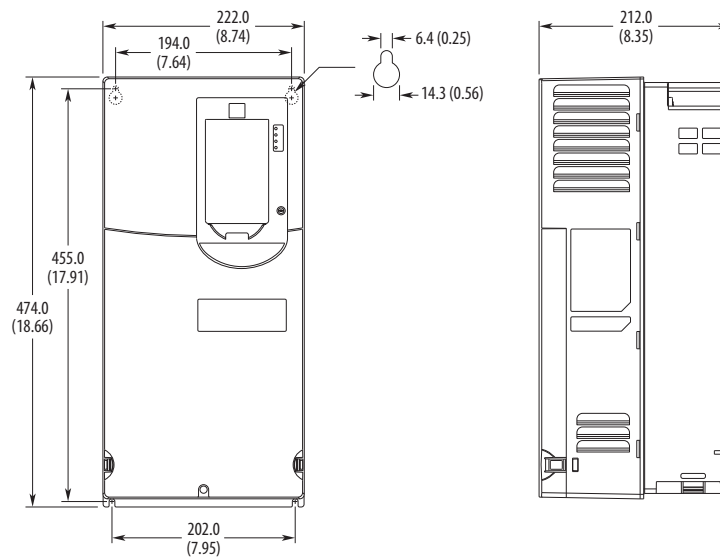

Frame	Type	Approximate Dimensions – mm (in.)
-------	------	-----------------------------------

4 Flange Mount

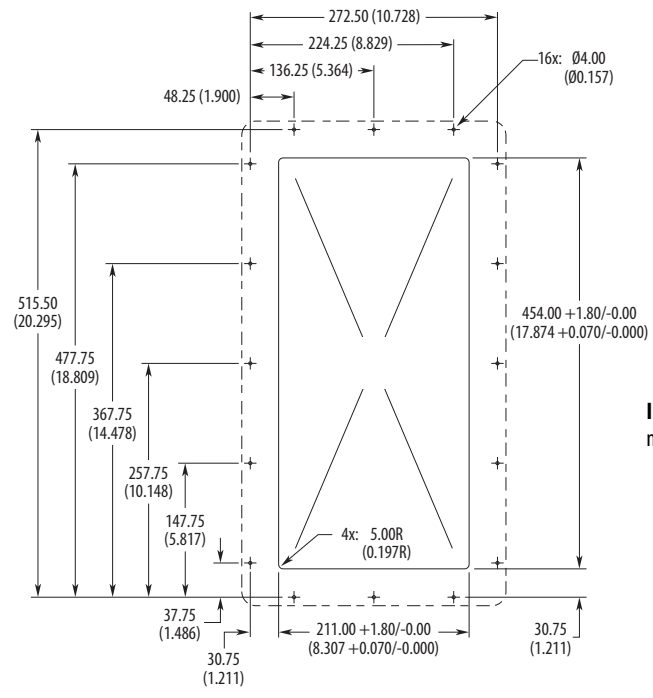
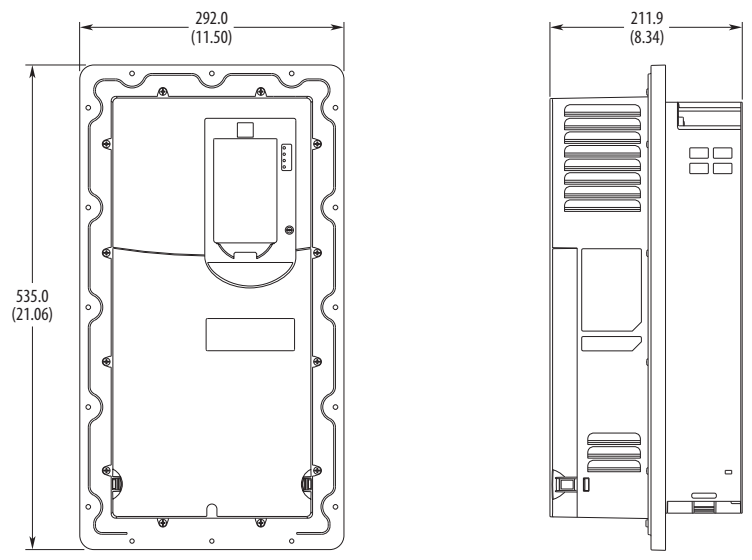

Important: Supplied mounting hardware must be used to meet enclosure rating.

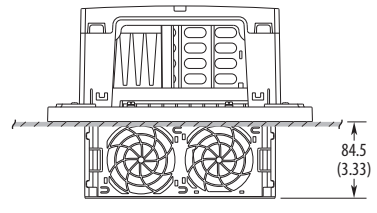

Frame	Type	Approximate Dimensions – mm (in.)
-------	------	-----------------------------------

4 IP54,
NEMA/UL Type 12

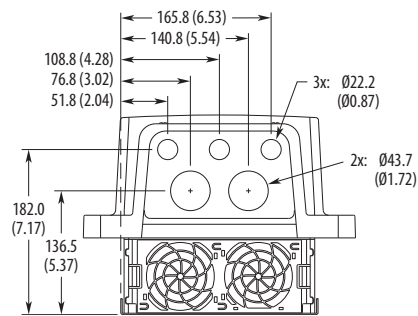
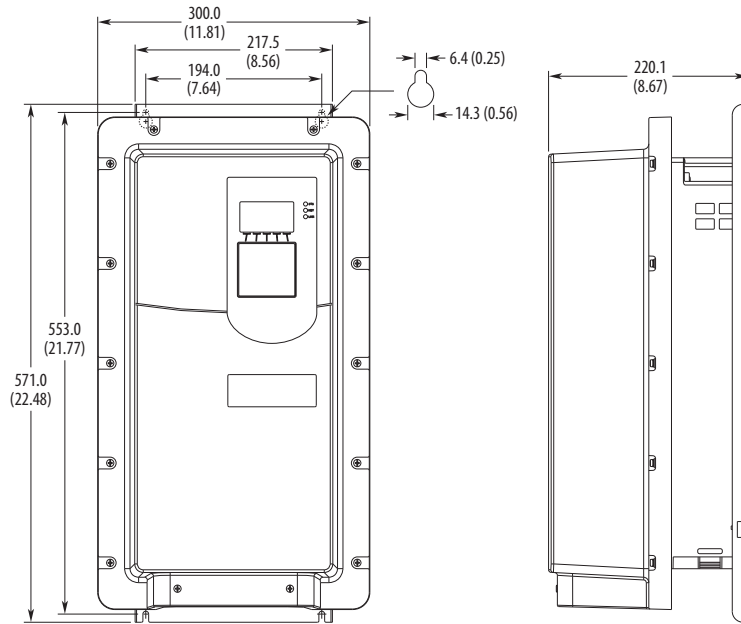

5 IP20,
NEMA/UL Open Type

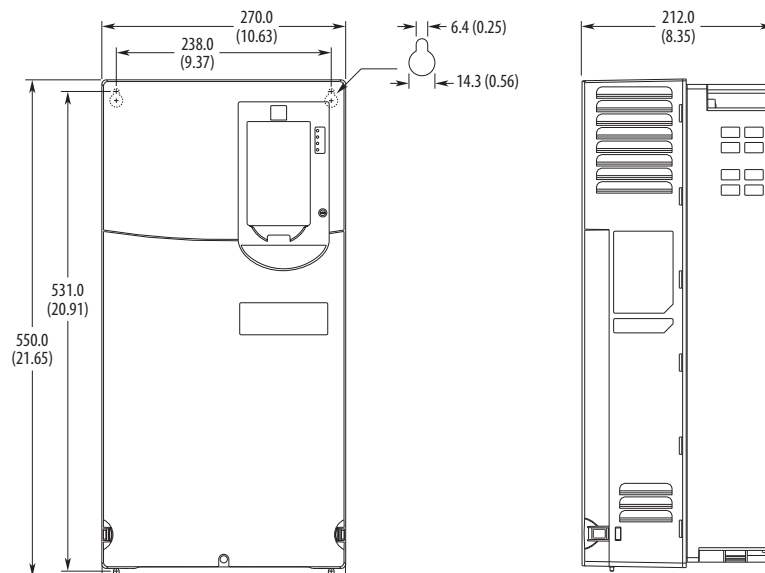

Frame	Type	Approximate Dimensions – mm (in.)
5	Flange Mount	

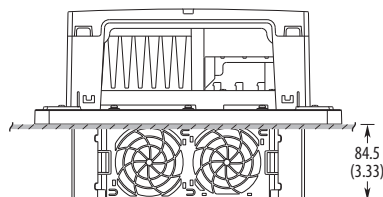
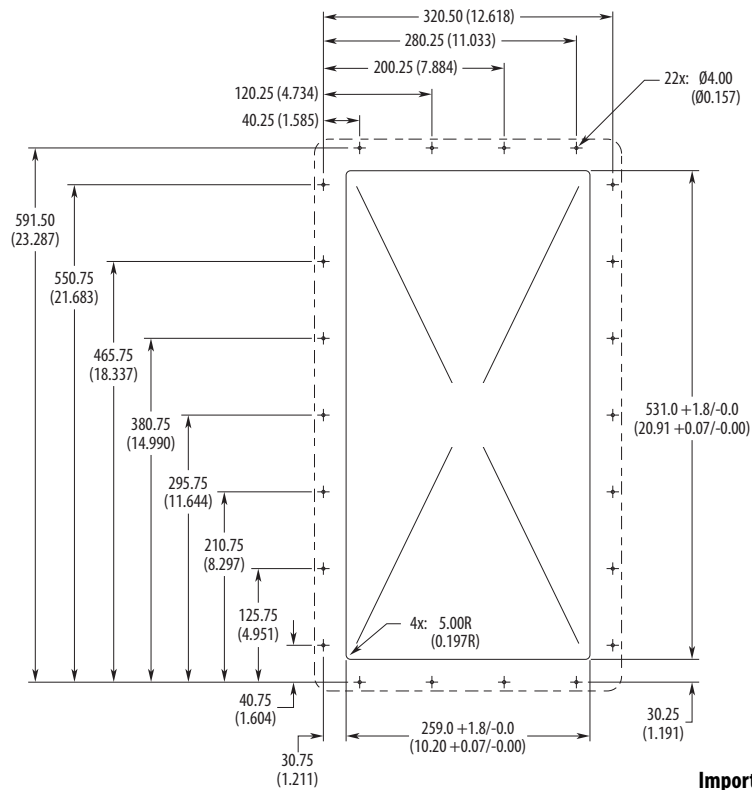
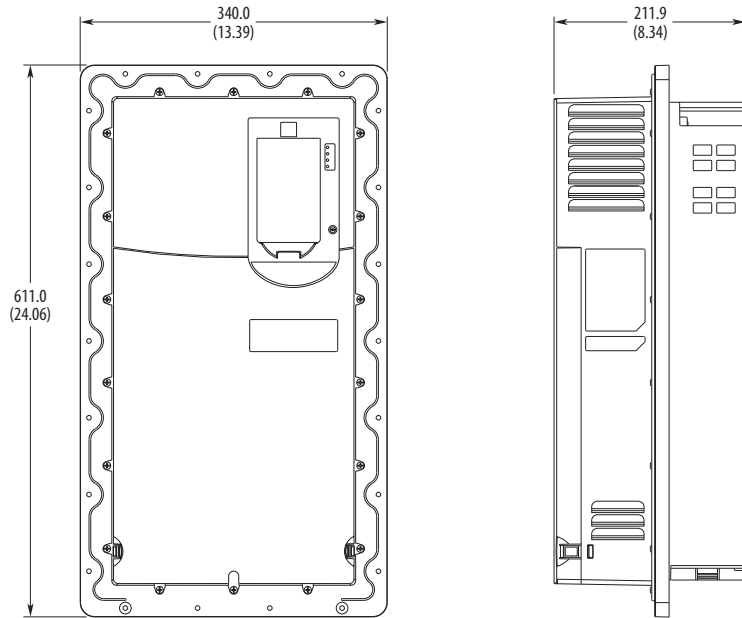

Important: Supplied mounting hardware must be used to meet enclosure rating.

Frame	Type	Approximate Dimensions – mm (in.)
-------	------	-----------------------------------

5	IP54, NEMA/UL Type 12	
---	--------------------------	--

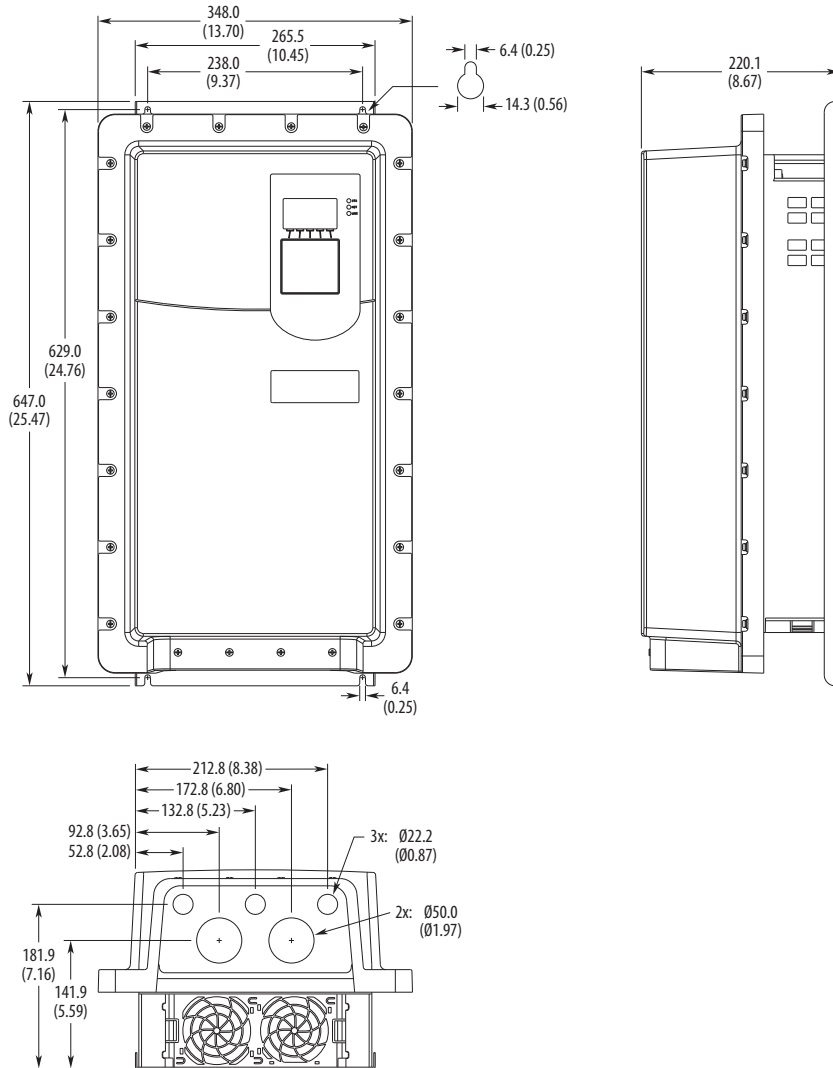

Frame	Type	Approximate Dimensions – mm (in.)
-------	------	-----------------------------------

6	IP00, NEMA/UL Open Type	
---	----------------------------	--

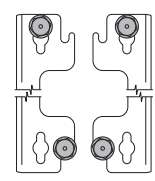
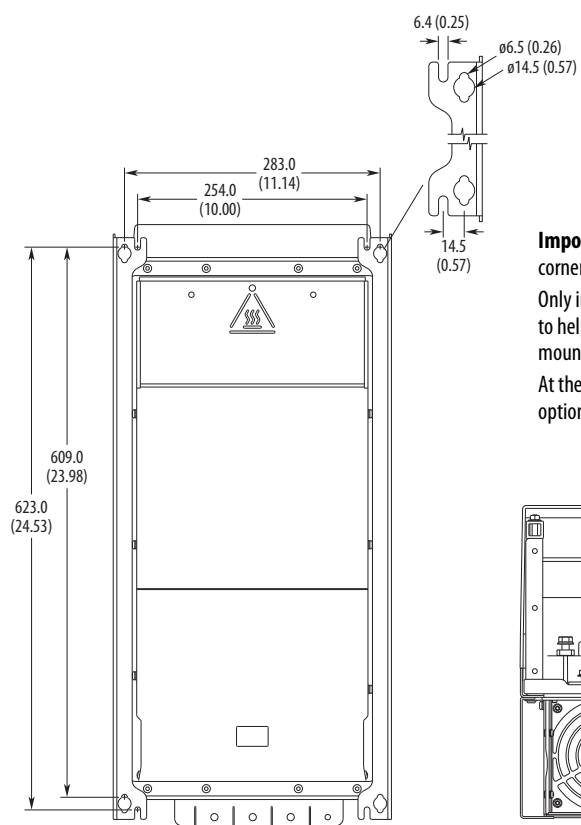
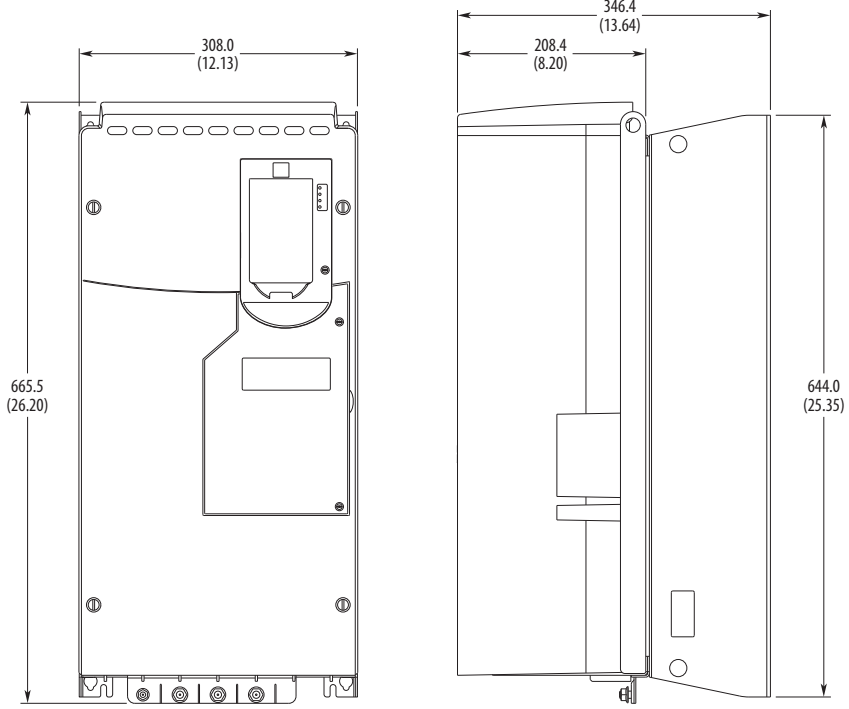

Important: Always install mounting hardware in all four corners of the mounting legs for stability.

Only install mounting hardware through the top key holes to help insure the drive is securely fastened to the mounting surface.

At the bottom of the mounting legs, either the key holes or optional open mounting slots can be used.

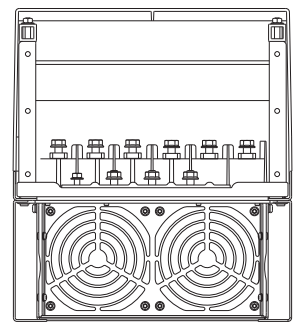

Frame

Type

Approximate Dimensions – mm (in.)

6 Flange Mount

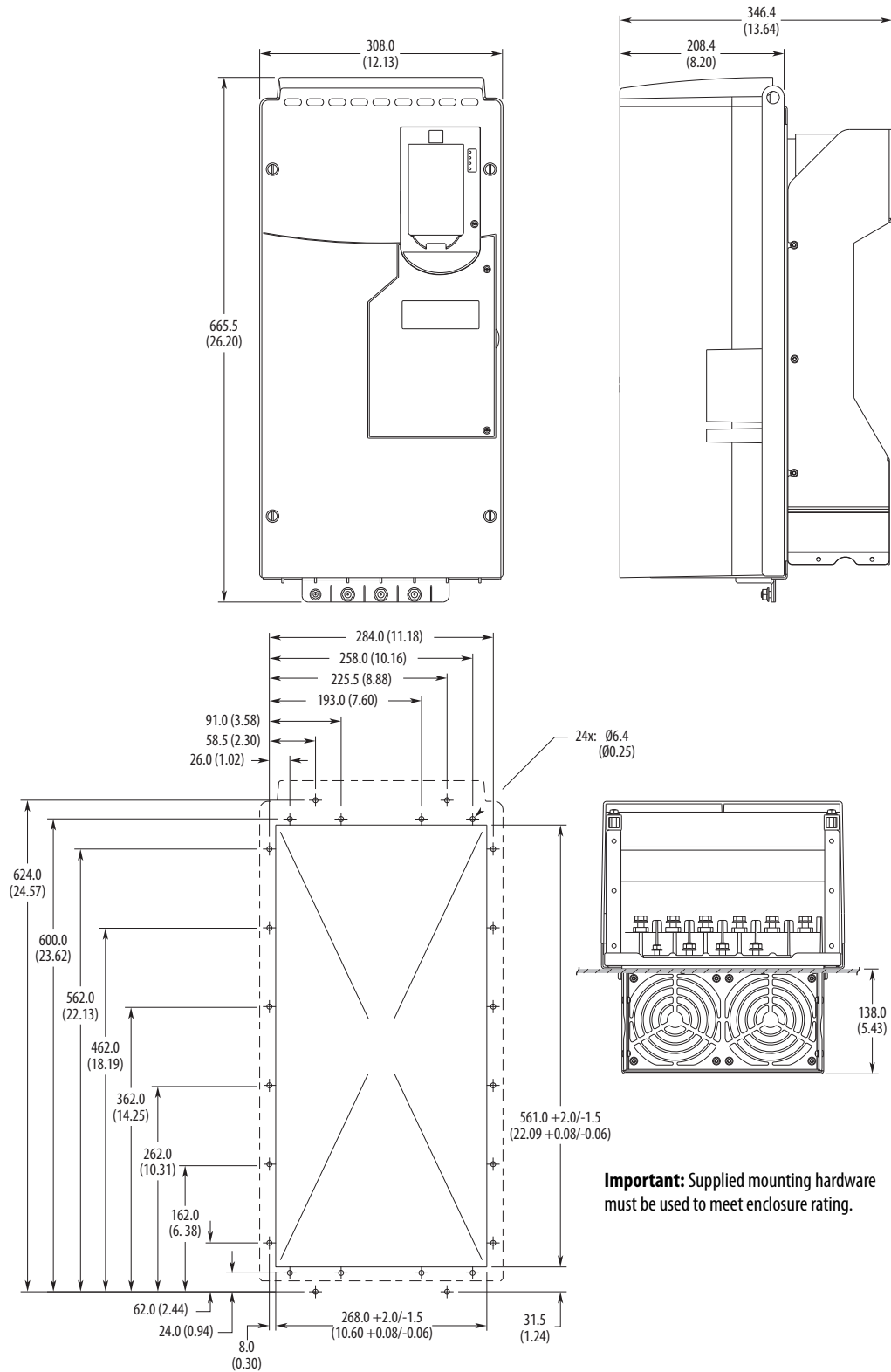

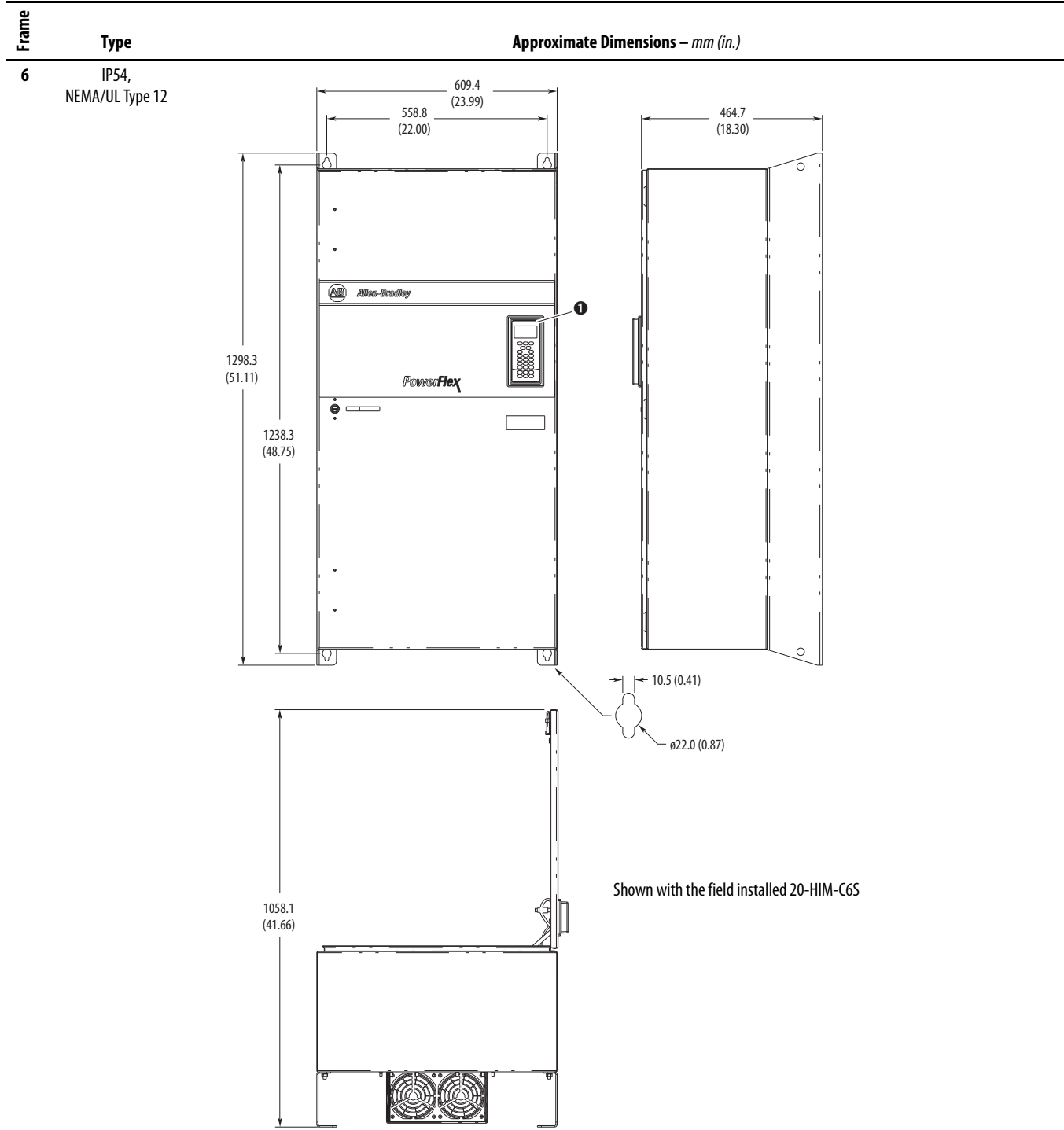

Frame	Type	Approximate Dimensions – mm (in.)
-------	------	-----------------------------------

7	IP00, NEMA/UL Open Type	
---	----------------------------	--

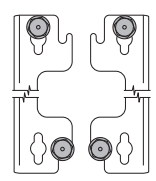
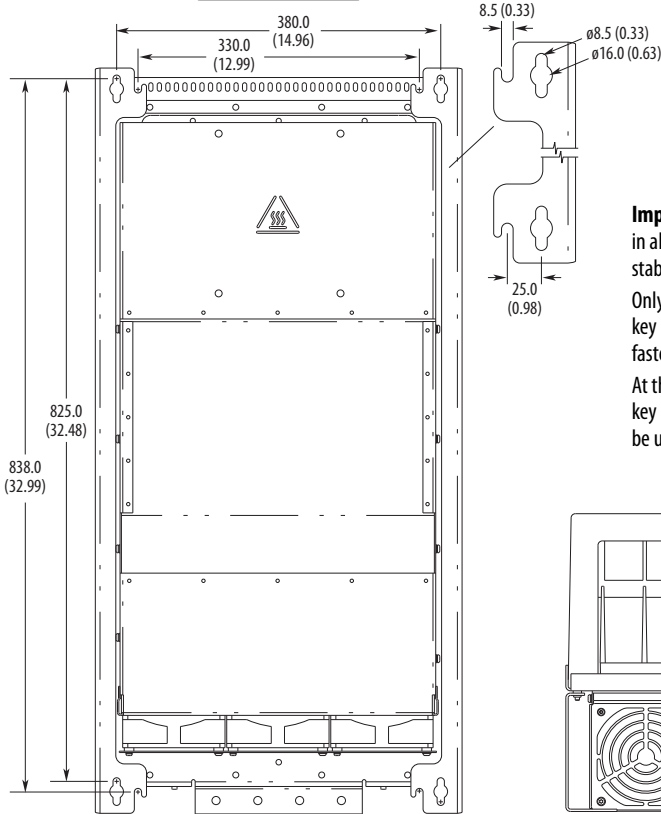
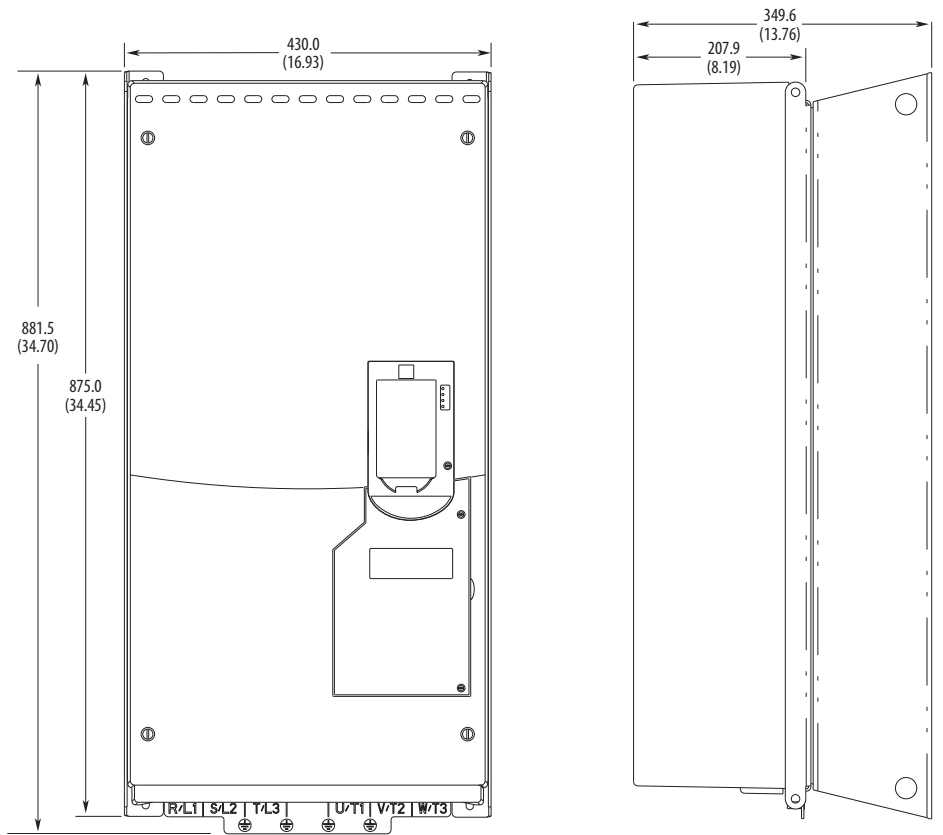

Important: Always install mounting hardware in all four corners of the mounting legs for stability.

Only install mounting hardware through the top key holes to help insure the drive is securely fastened to the mounting surface.

At the bottom of the mounting legs, either the key holes or optional open mounting slots can be used.

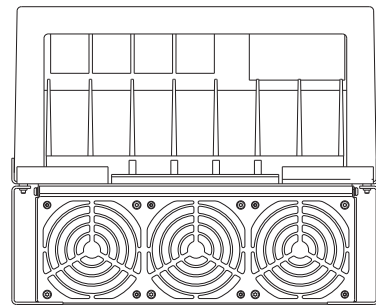

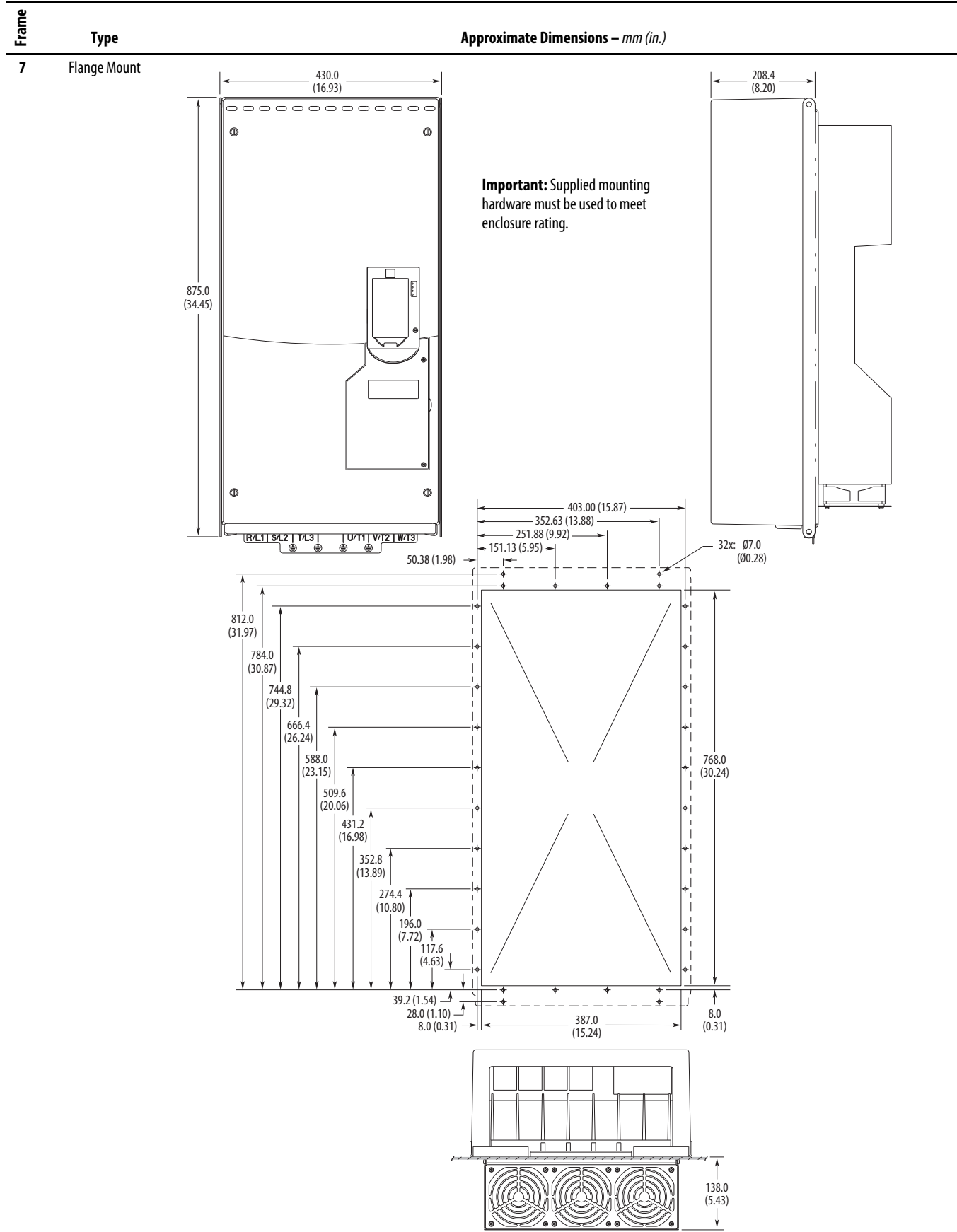

Frame	Type	Approximate Dimensions – mm (in.)
-------	------	-----------------------------------

7 NEMA/UL Type 1

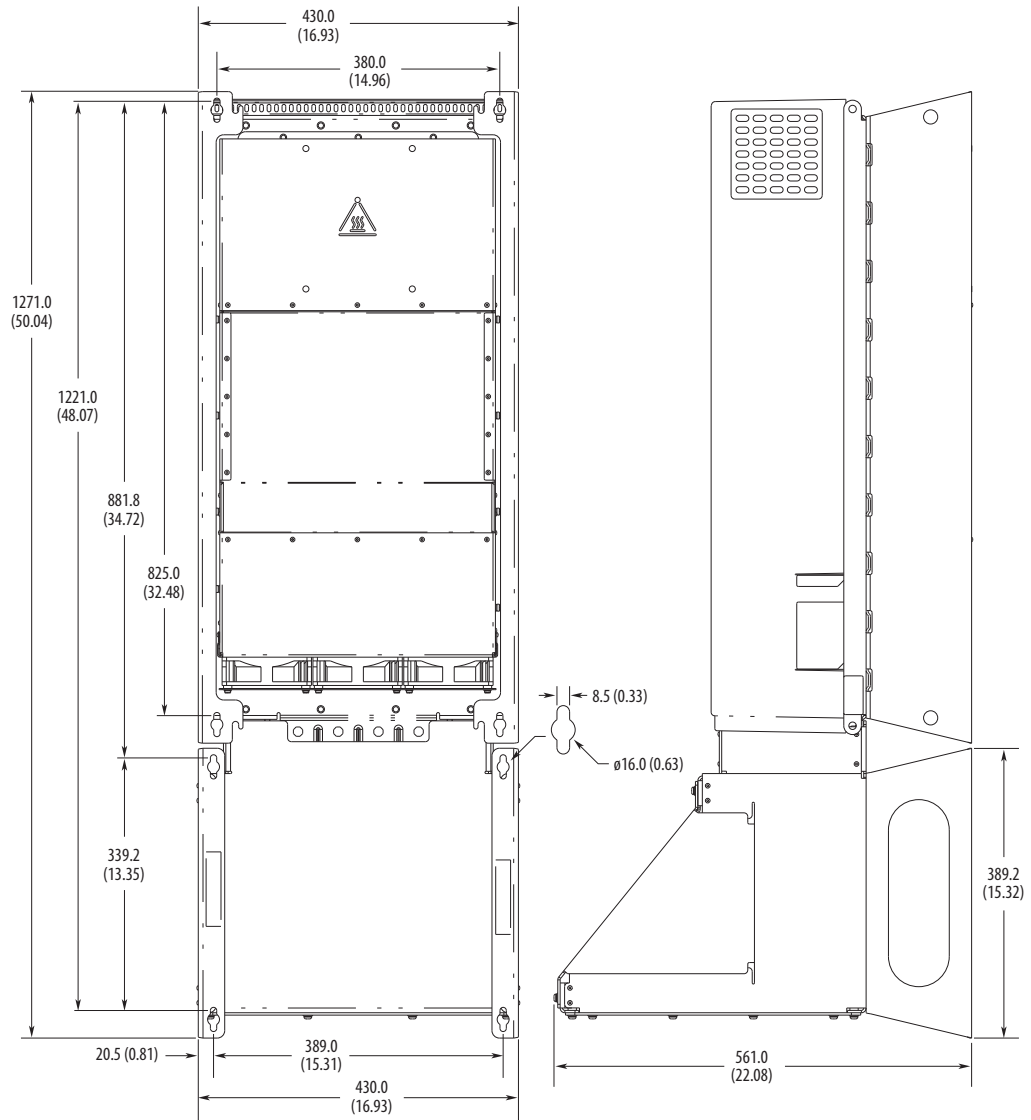

Frame	Type	Approximate Dimensions – mm (in.)
7	IP54, NEMA/UL Type 12	

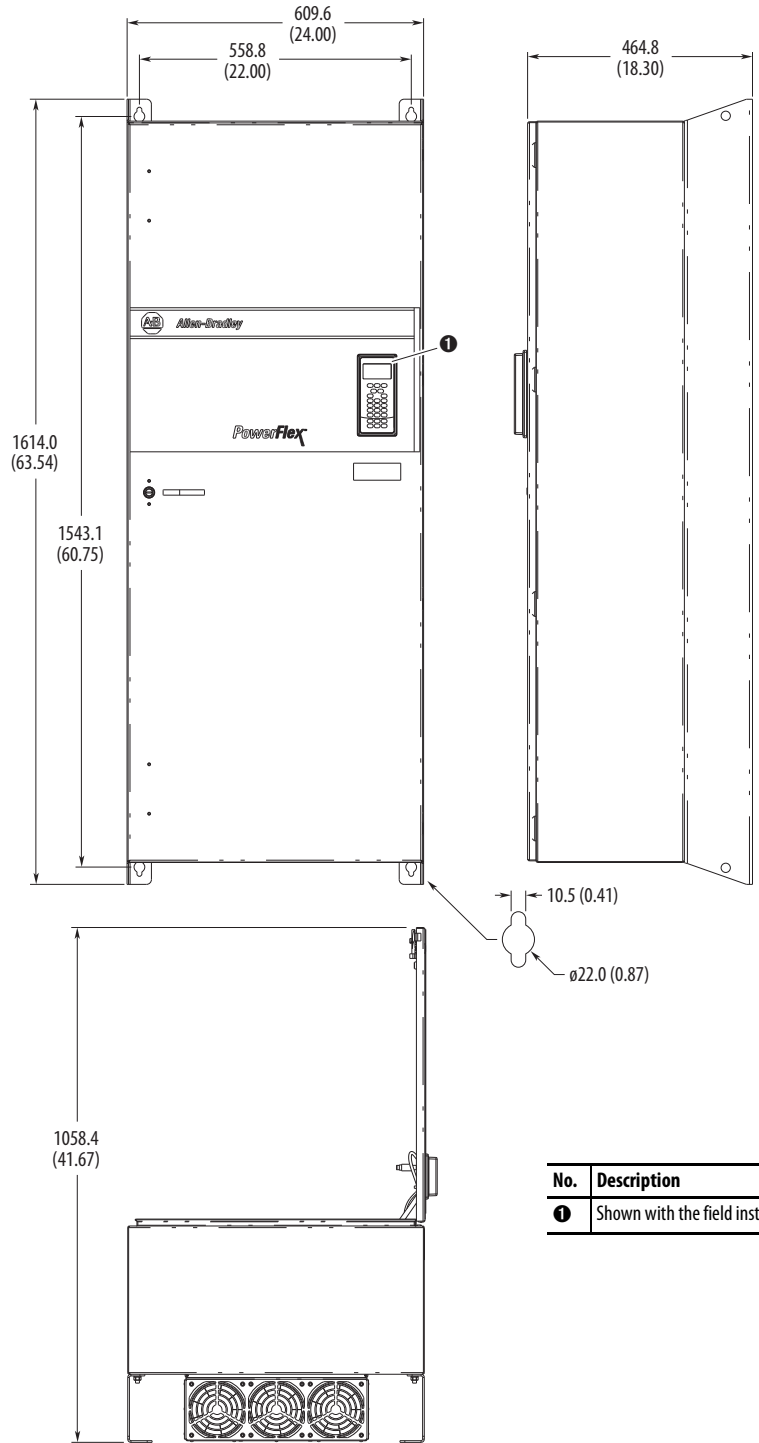

No.	Description
1	Shown with the field installed 20-HIM-C6S

Frame

Type

Approximate Dimensions – mm (in.)

- 8** MCC Style Cabinet,
600 mm (23.6 in.)
Deep
IP20, NEMA/UL Type 1
Enclosure Code B

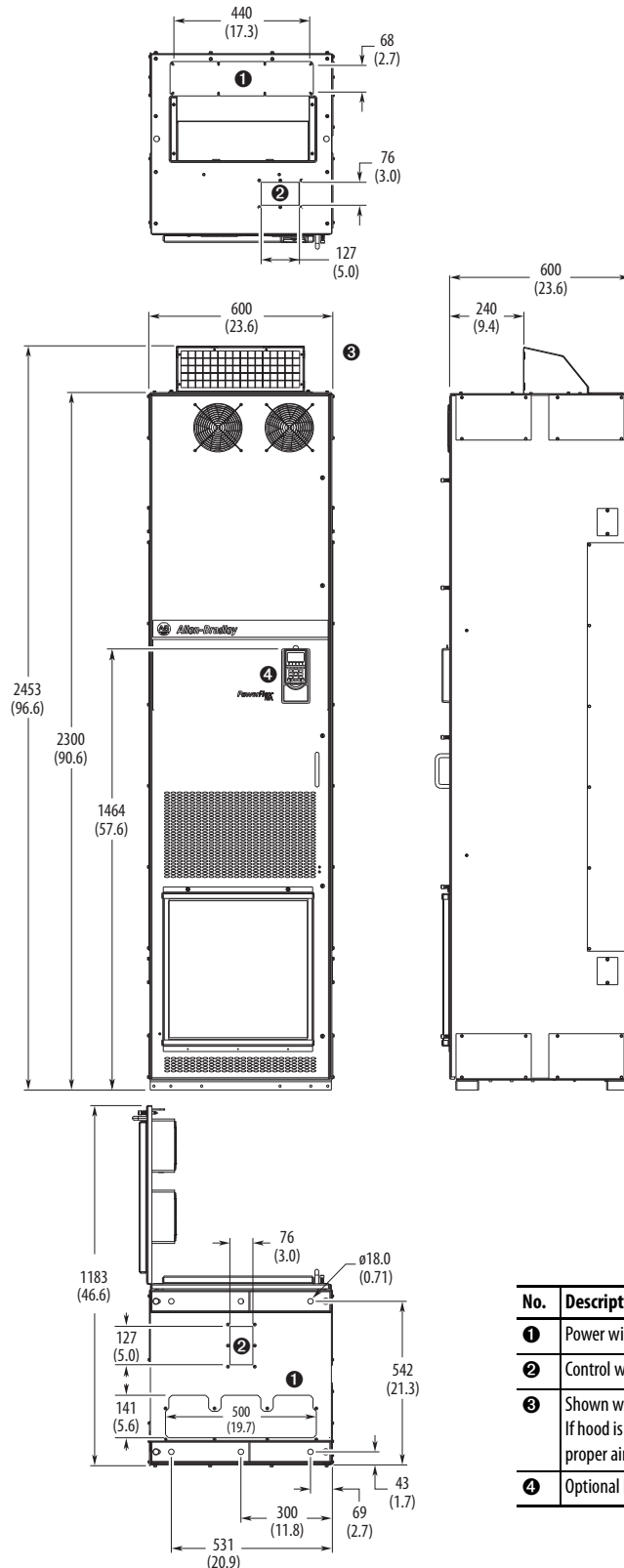

No.	Description
1	Power wiring conduit plates.
2	Control wiring conduit plates.
3	Shown with optional hood (20-750-HOOD1-F8). If hood is not used, allow sufficient top clearance for proper airflow. See page 71 .
4	Optional HIM.

Frame

Type

Approximate Dimensions – mm (in.)

- 8** MCC Style Cabinet with Wiring Bay, 600 mm (23.6 in.) Deep IP20, NEMA/UL Type 1 Enclosure Code B

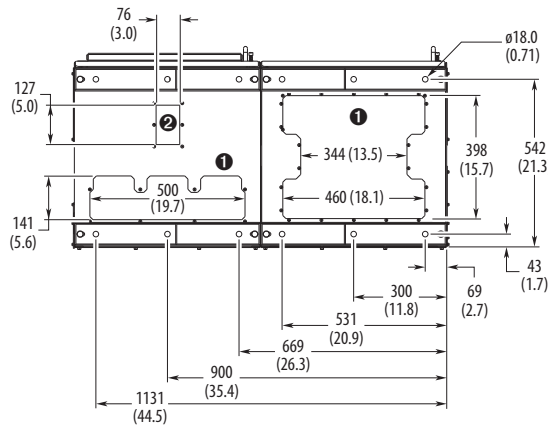
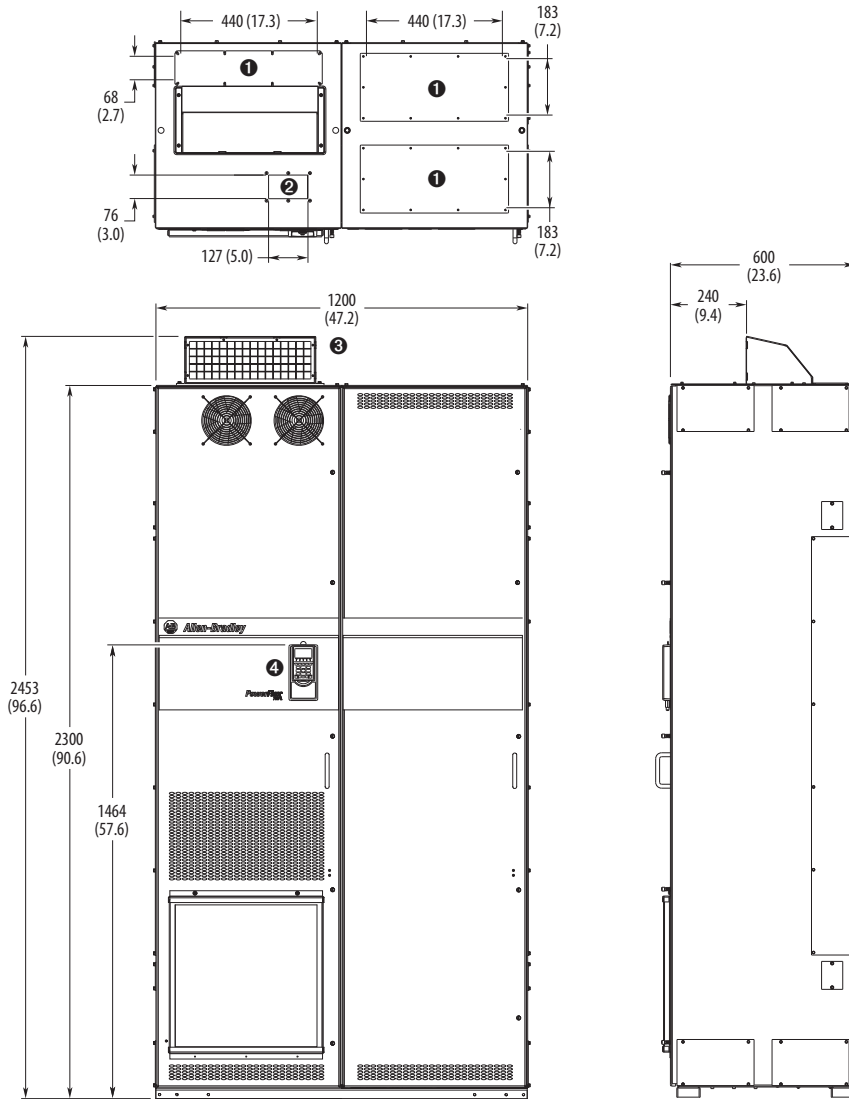

No.	Description
1	Power wiring conduit plates.
2	Control wiring conduit plates.
3	Shown with optional hood (20-750-HOOD1-F8). If hood is not used, allow sufficient top clearance for proper airflow. See page 71 .
4	Optional HIM.

Frame

Type

Approximate Dimensions – mm (in.)

- 8** MCC Style Cabinet with Cabinet Option Bay, 600 mm (23.6 in.) Deep
- IP20, NEMA/UL Type 1 Enclosure Code B

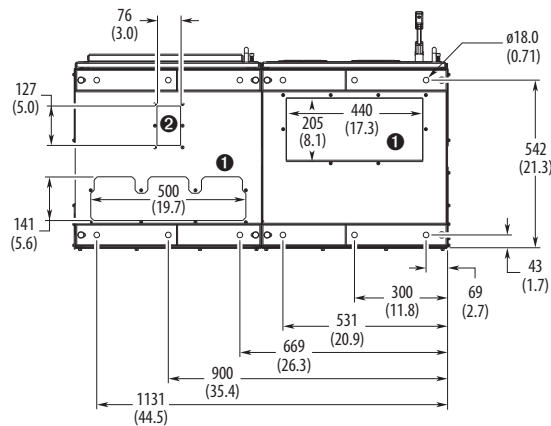
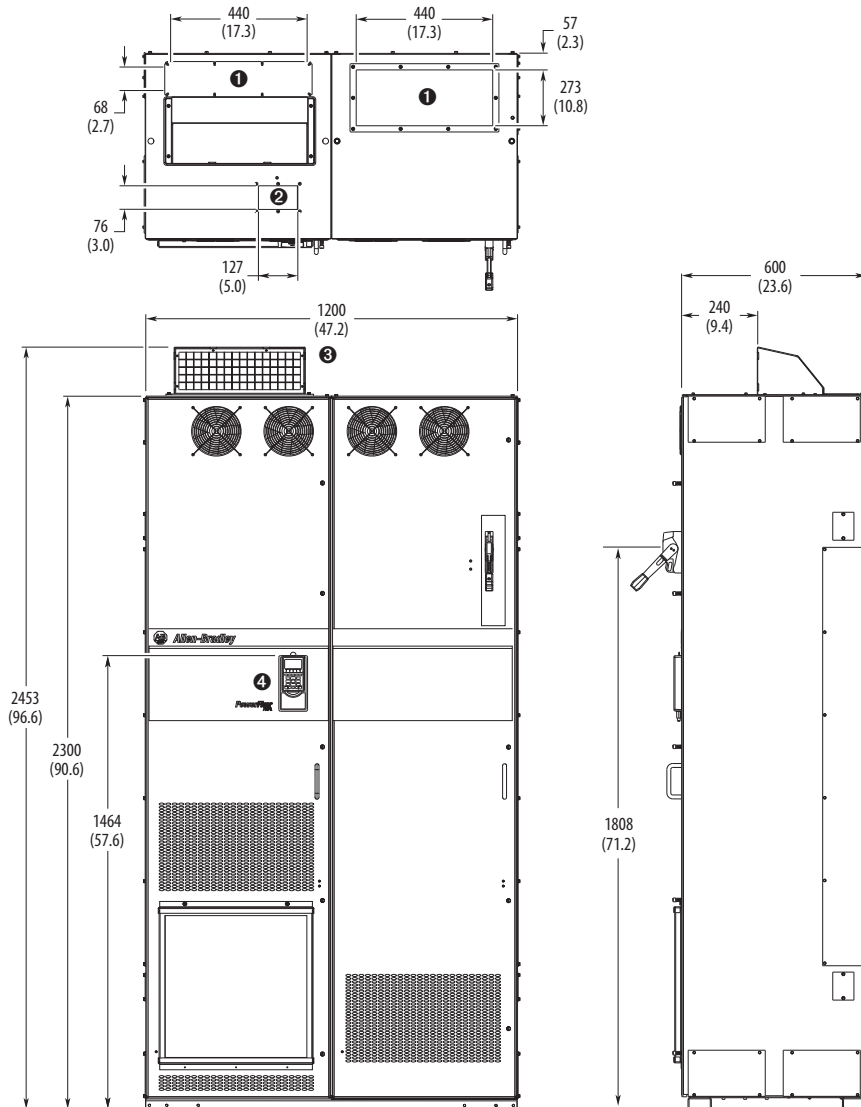

No.	Description
1	Power wiring conduit plates.
2	Control wiring conduit plates.
3	Shown with optional hood (20-750-HOOD1-F8). If hood is not used, allow sufficient top clearance for proper airflow. See page 71 .
4	Optional HIM.

Frame

Type

Approximate Dimensions – mm (in.)

- 8** MCC Style Cabinet with Wiring Bay and Cabinet Option Bay, 600 mm (23.6 in.) Deep
- IP20, NEMA/UL Type 1 Enclosure Code B

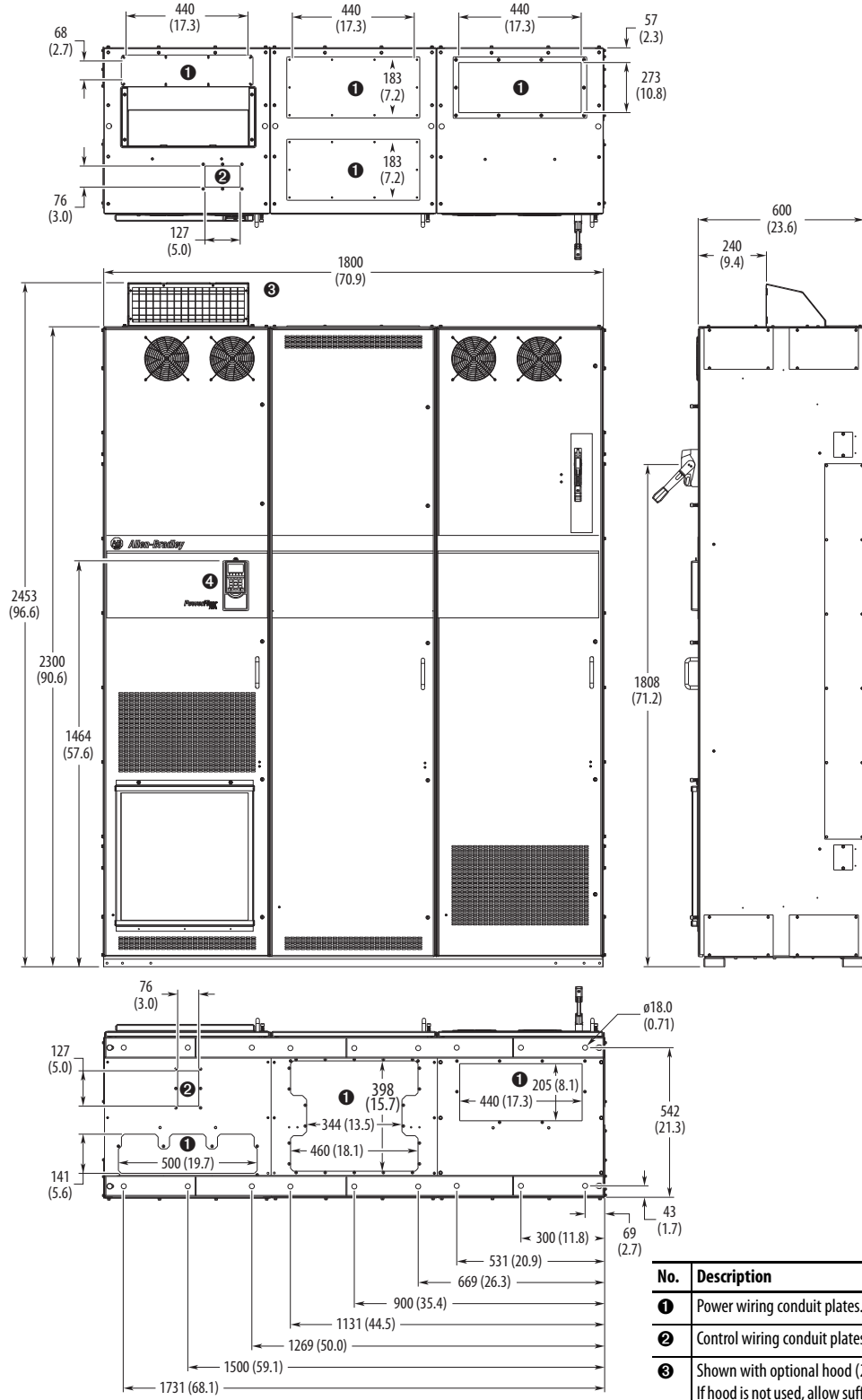

No.	Description
1	Power wiring conduit plates.
2	Control wiring conduit plates.
3	Shown with optional hood (20-750-HOOD1-F8). If hood is not used, allow sufficient top clearance for proper airflow. See page 71 .
4	Optional HIM.

Frame

Type

Approximate Dimensions – mm (in.)

- 8 MCC Style Cabinet,
800 mm (31.5 in.)
Deep
- IP20, NEMA/UL Type 1
Enclosure Code L
(AC Input)
- Enclosure Codes P, W
(DC Input)

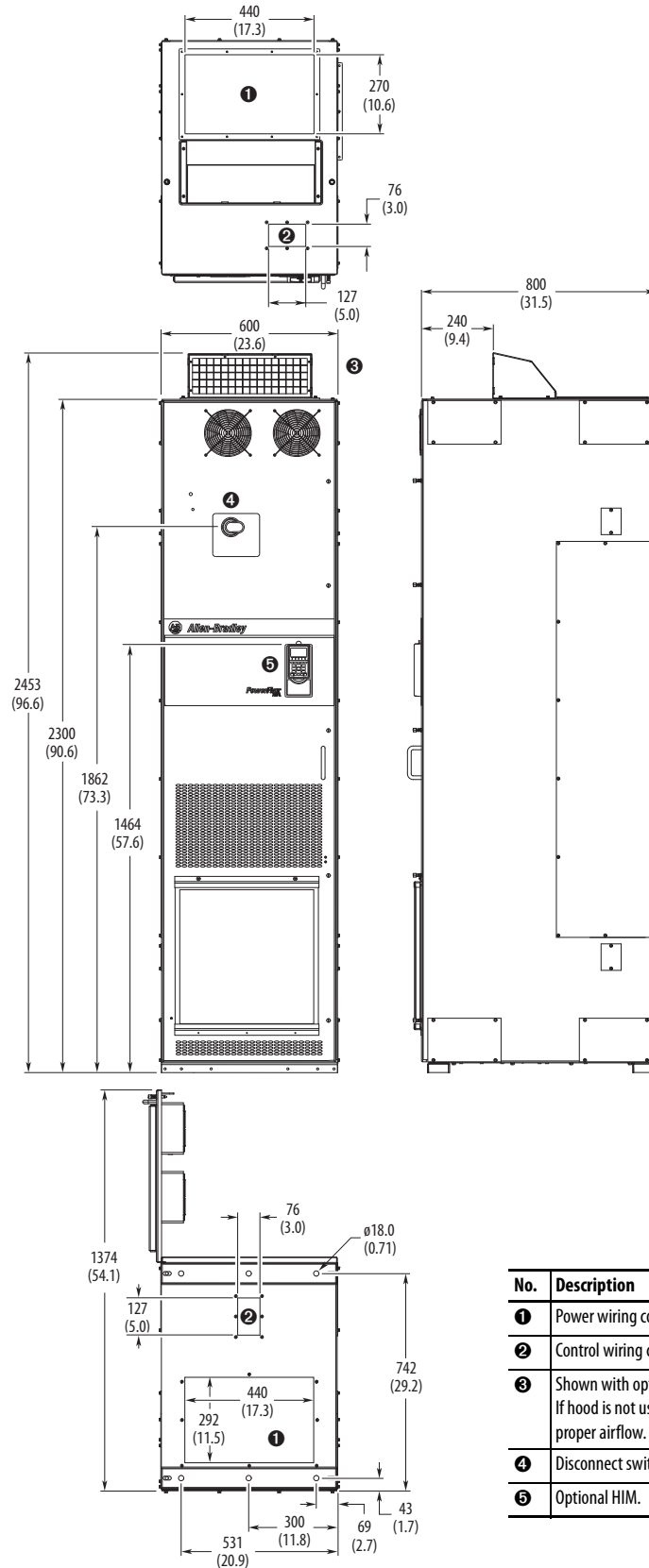

No.	Description
1	Power wiring conduit plates.
2	Control wiring conduit plates.
3	Shown with optional hood (20-750-HOOD1-F8). If hood is not used, allow sufficient top clearance for proper airflow. See page 71 .
4	Disconnect switch - Common DC Input drives.
5	Optional HIM.

Frame

Type

Approximate Dimensions – mm (in.)

- 8 MCC Style Cabinet with Wiring Bay, 800 mm (31.5 in.) Deep IP20, NEMA/UL Type 1 Enclosure Code L, P, W

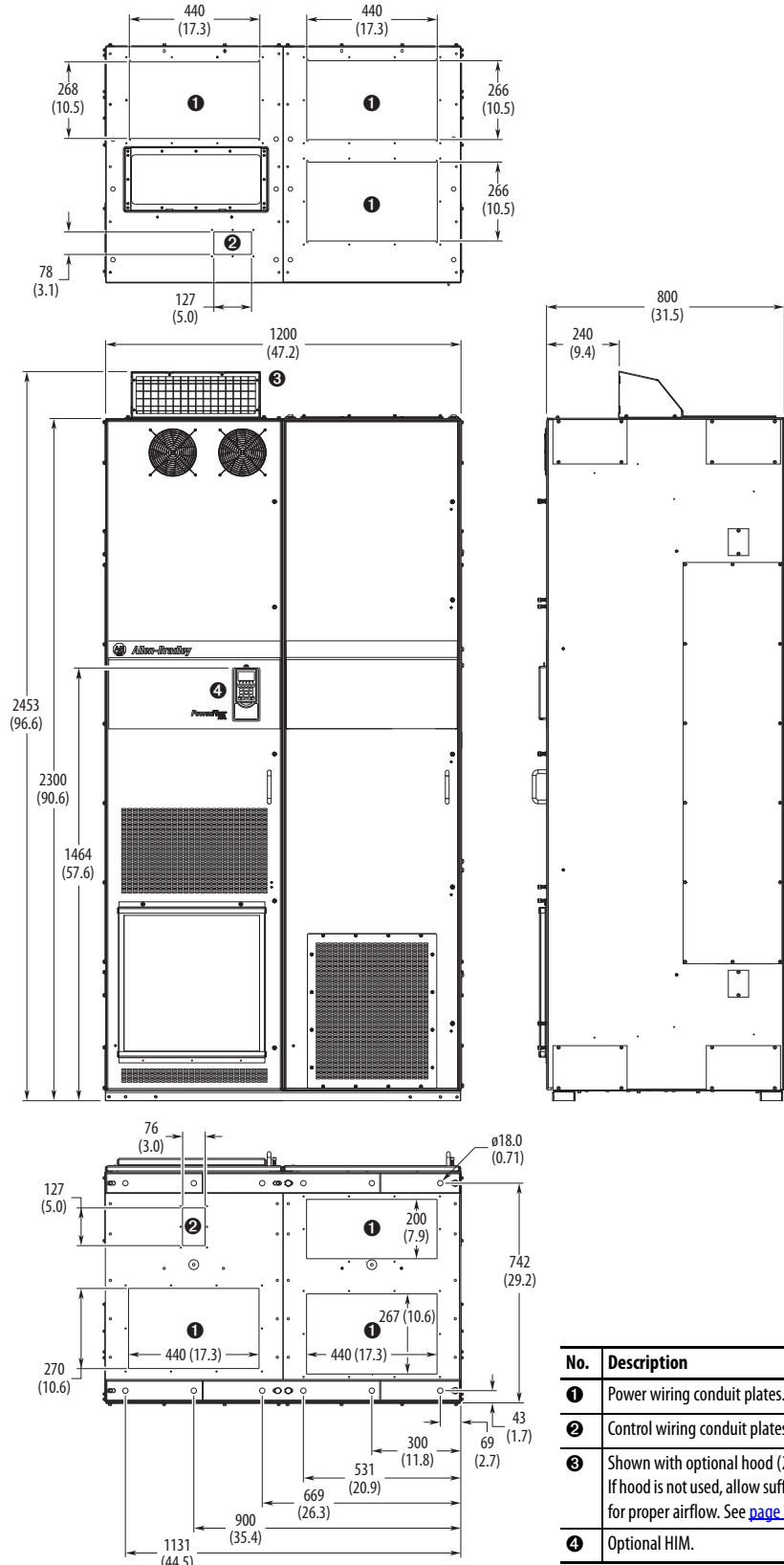

No.	Description
1	Power wiring conduit plates.
2	Control wiring conduit plates.
3	Shown with optional hood (20-750-HOOD1-F8). If hood is not used, allow sufficient top clearance for proper airflow. See page 71 .
4	Optional HIM.

Frame

Type

Approximate Dimensions – mm (in.)

- 8** MCC Style Cabinet with Cabinet Option Bay, 800 mm (31.5 in.) Deep
- IP20, NEMA/UL Type 1 Enclosure Codes L, P, W

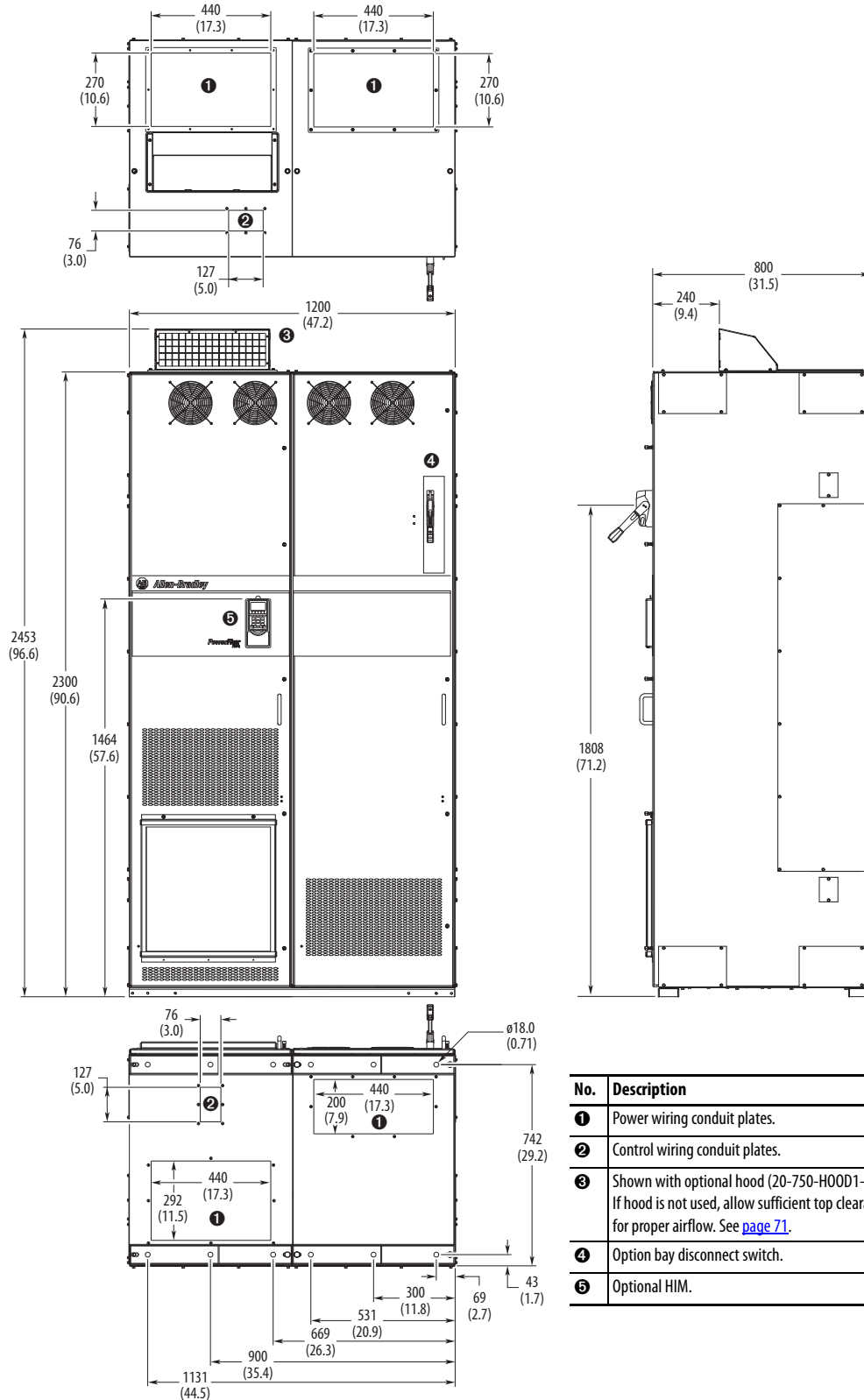

No.	Description
1	Power wiring conduit plates.
2	Control wiring conduit plates.
3	Shown with optional hood (20-750-HOOD1-F8). If hood is not used, allow sufficient top clearance for proper airflow. See page 71 .
4	Option bay disconnect switch.
5	Optional HIM.

Frame

Type

Approximate Dimensions – mm (in.)

8 MCC Style Cabinet with Wiring Bay and Cabinet Option Bay, 800 mm (31.5 in.) Deep
IP20, NEMA/UL Type 1 Enclosure Code L, P, W

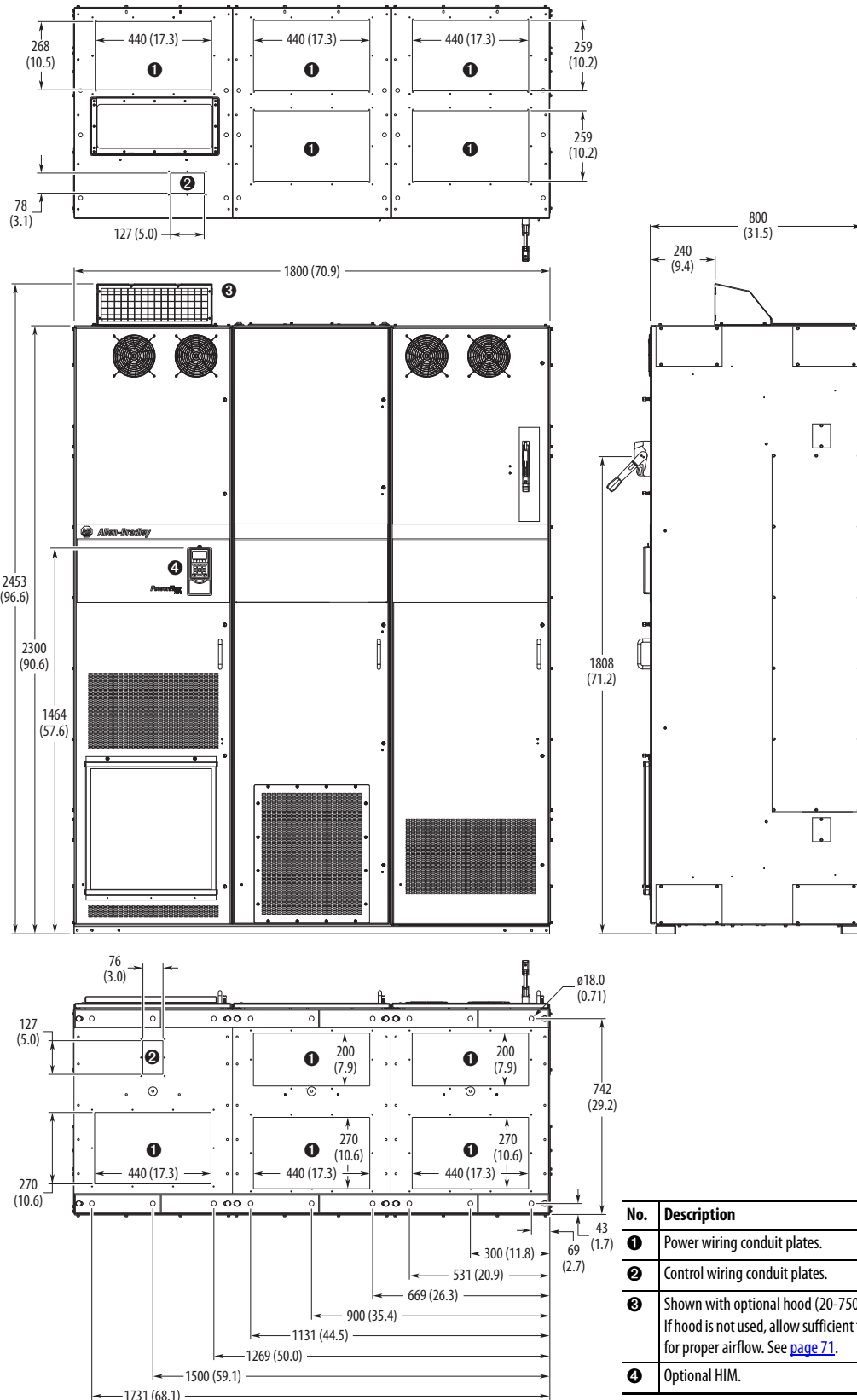

No.	Description
1	Power wiring conduit plates.
2	Control wiring conduit plates.
3	Shown with optional hood (20-750-HOOD1-F8). If hood is not used, allow sufficient top clearance for proper airflow. See page 71 .
4	Optional HIM.

Frame

Type

Approximate Dimensions – mm (in.)

- 8** MCC Style Cabinet,
800 mm (31.5 in.)
Deep
- IP54, NEMA 12
Enclosure Codes K, Y
(DC Input)
- IP54, UL Type 12
Enclosure Code J
(AC Input)

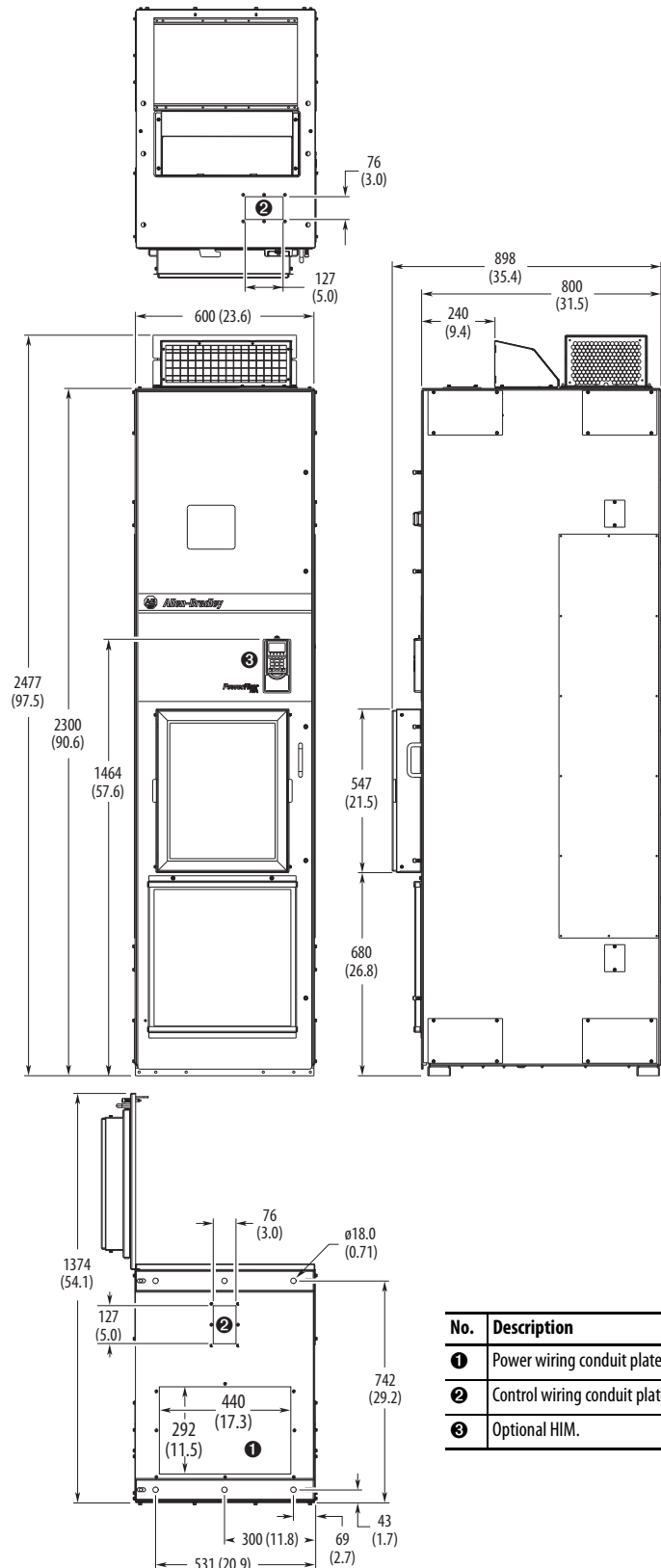

No.	Description
1	Power wiring conduit plates.
2	Control wiring conduit plates.
3	Optional HIM.

Frame

Type

Approximate Dimensions – mm (in.)

- 8 MCC Style Cabinet with Wiring Bay, 800 mm (31.5 in.) Deep
- IP54, NEMA 12 Enclosure Codes K, Y (DC Input)
- IP54, UL Type 12 Enclosure Code J (AC Input)

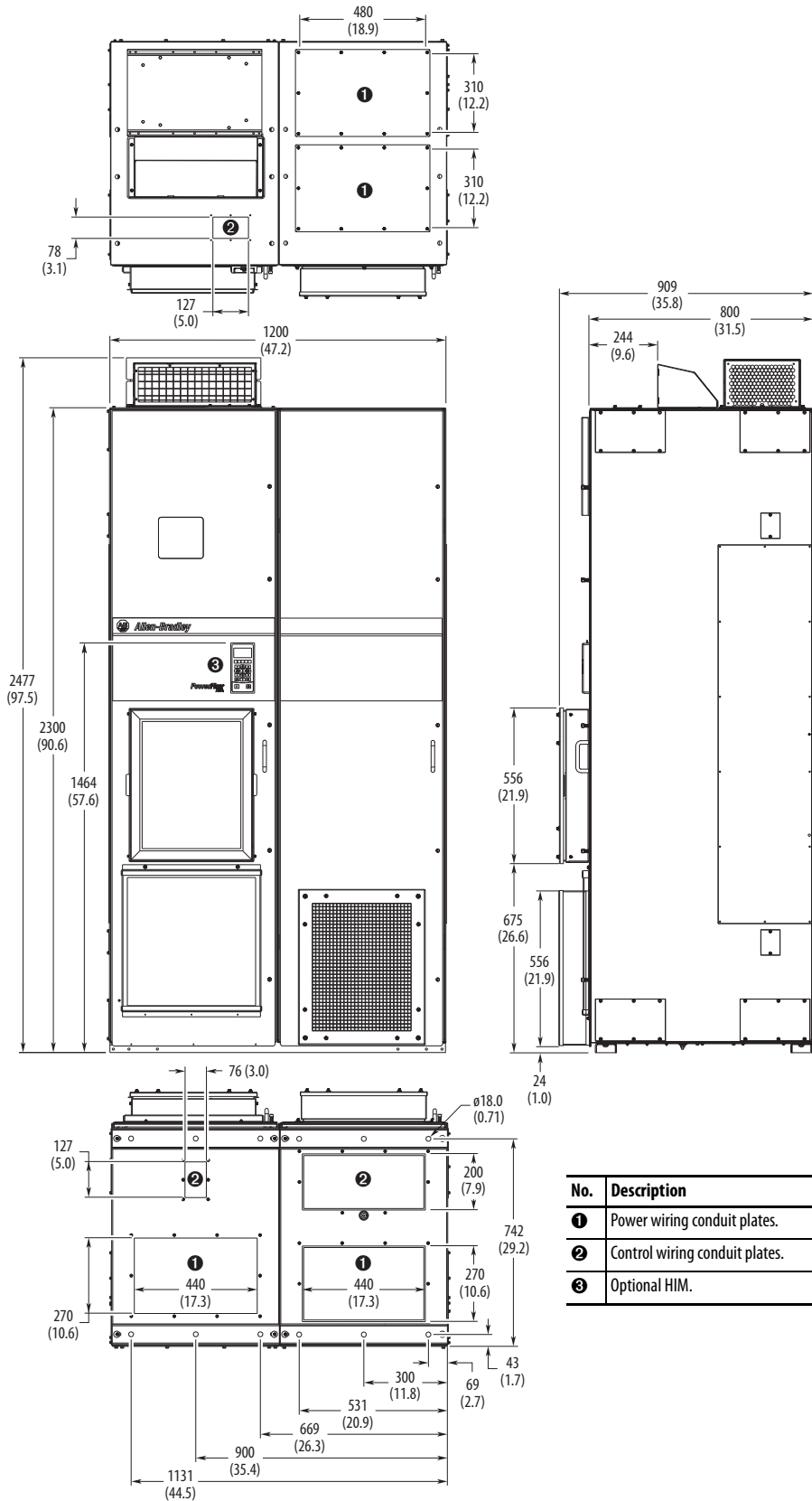

No.	Description
1	Power wiring conduit plates.
2	Control wiring conduit plates.
3	Optional HIM.

Frame

Type

Approximate Dimensions – mm (in.)

- 8** MCC Style Cabinet with Cabinet Option Bay, 800 mm (31.5 in.) Deep
- IP54, NEMA 12 Enclosure Codes K, Y (DC Input)
- IP54, UL Type 12 Enclosure Code J (AC Input)

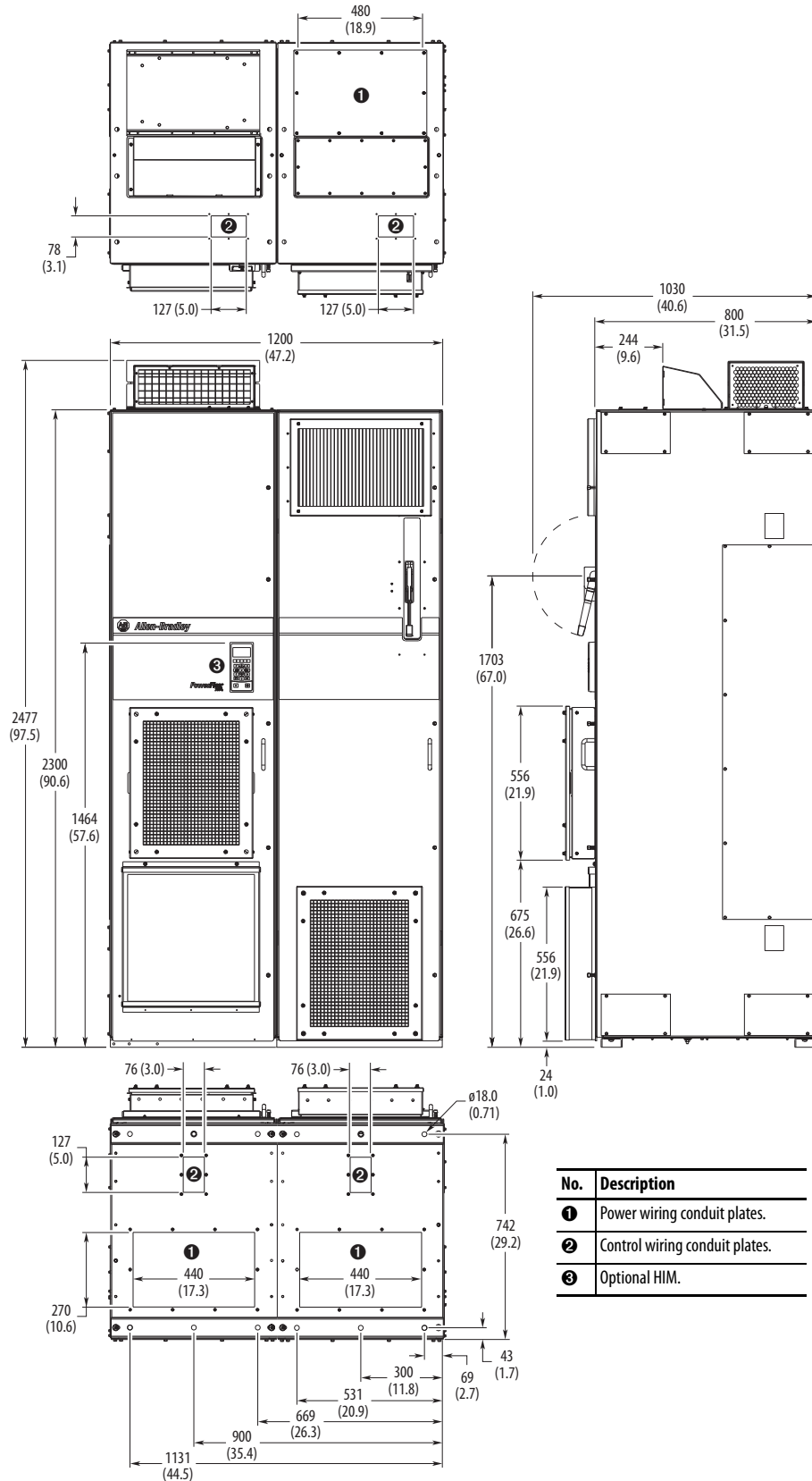

No.	Description
1	Power wiring conduit plates.
2	Control wiring conduit plates.
3	Optional HIM.

Frame

Type

Approximate Dimensions – mm (in.)

- 8 MCC Style Cabinet with Wiring Bay and Cabinet Option Bay, 800 mm (31.5 in.) Deep
- IP54, NEMA 12 Enclosure Codes K, Y (DC Input)
- IP54, UL Type 12 Enclosure Code J (AC Input)

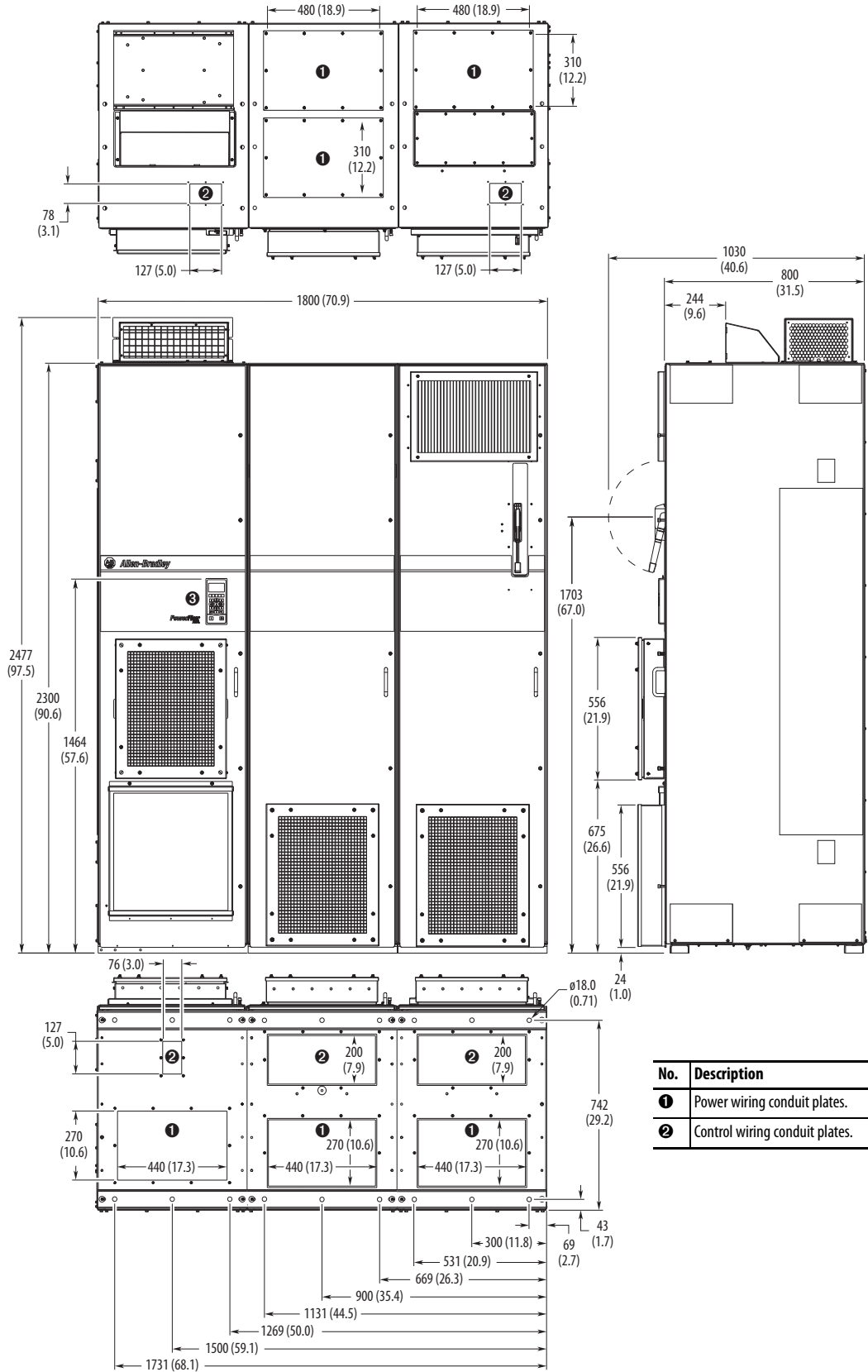

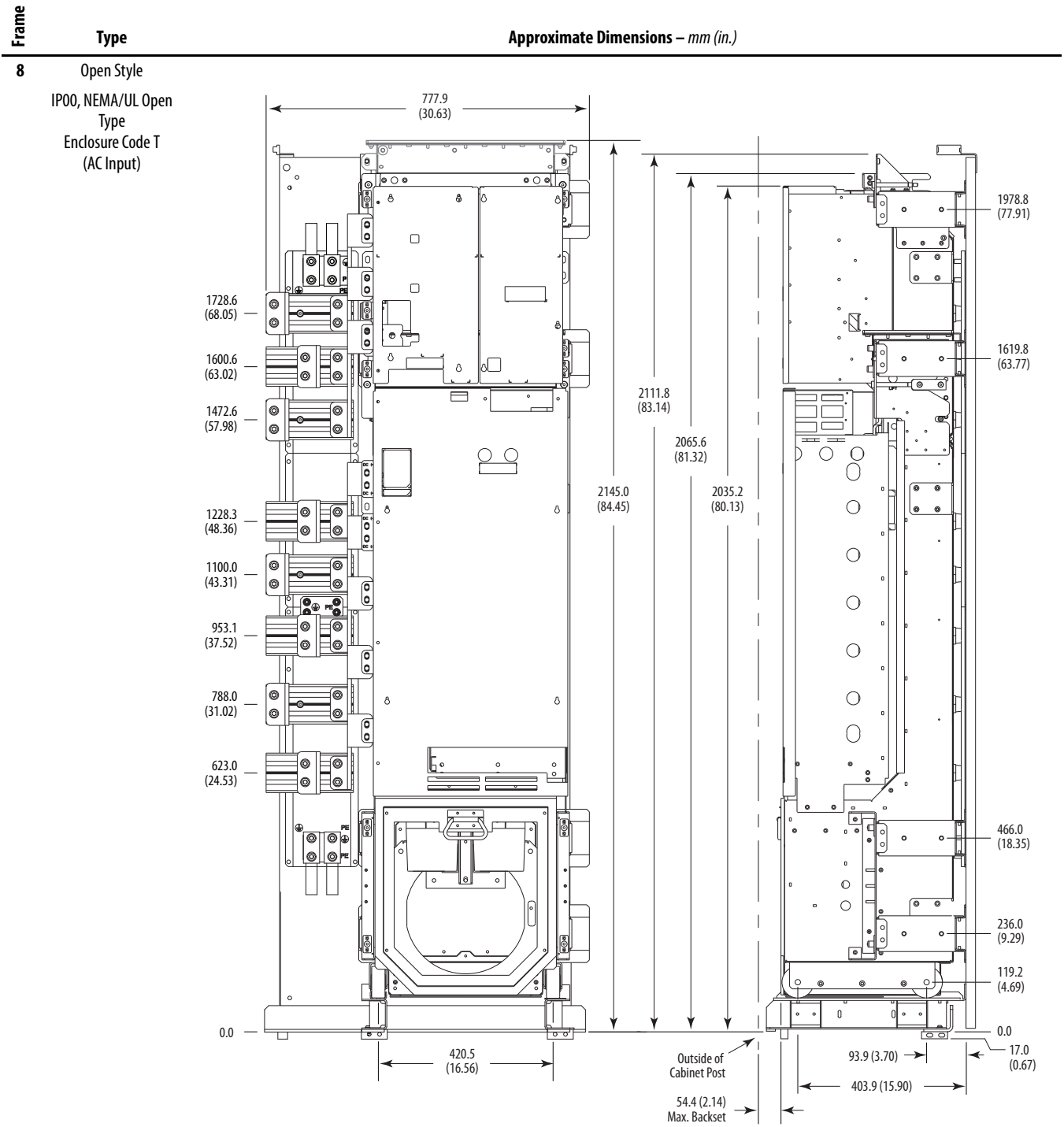

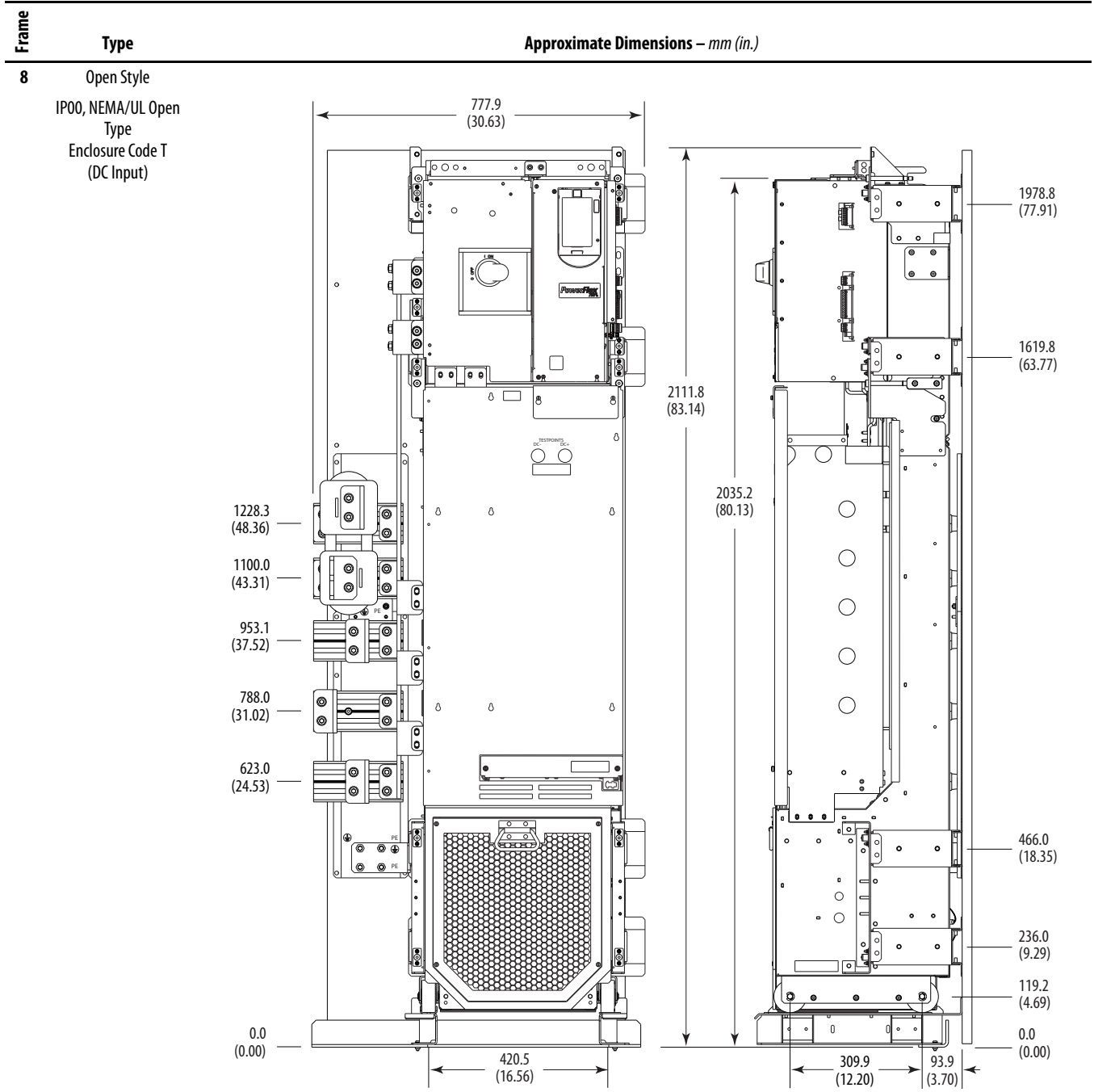

Frame

Type

Approximate Dimensions – mm (in.)

- 9 MCC Style Cabinet,
600 mm (23.6 in.)
Deep
IP20, NEMA/UL Type 1
Enclosure Code B

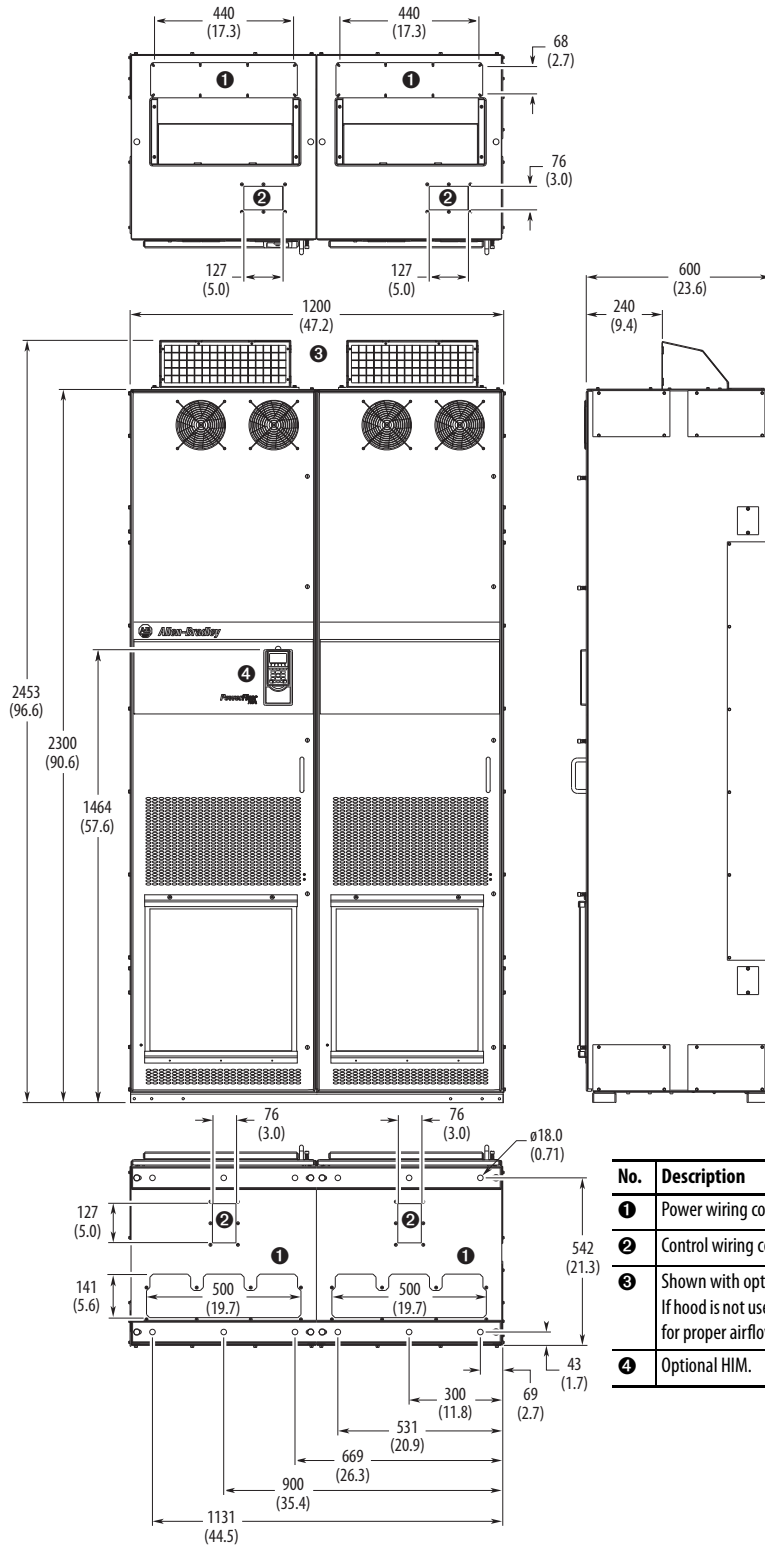

No.	Description
1	Power wiring conduit plates.
2	Control wiring conduit plates.
3	Shown with optional hood (20-750-HOOD1-F8). If hood is not used, allow sufficient top clearance for proper airflow. See page 71 .
4	Optional HIM.

Frame

Type

Approximate Dimensions – mm (in.)

- 9 MCC Style Cabinet with Wiring Bay, 600 mm (23.6 in.) Deep IP20, NEMA/UL Type 1 Enclosure Code B

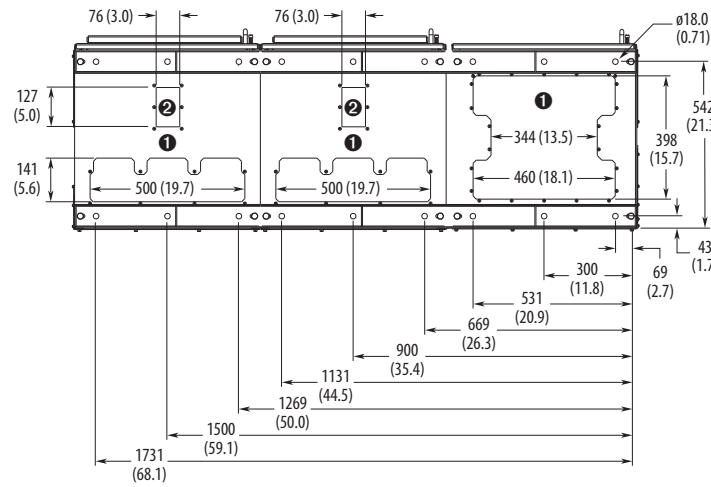
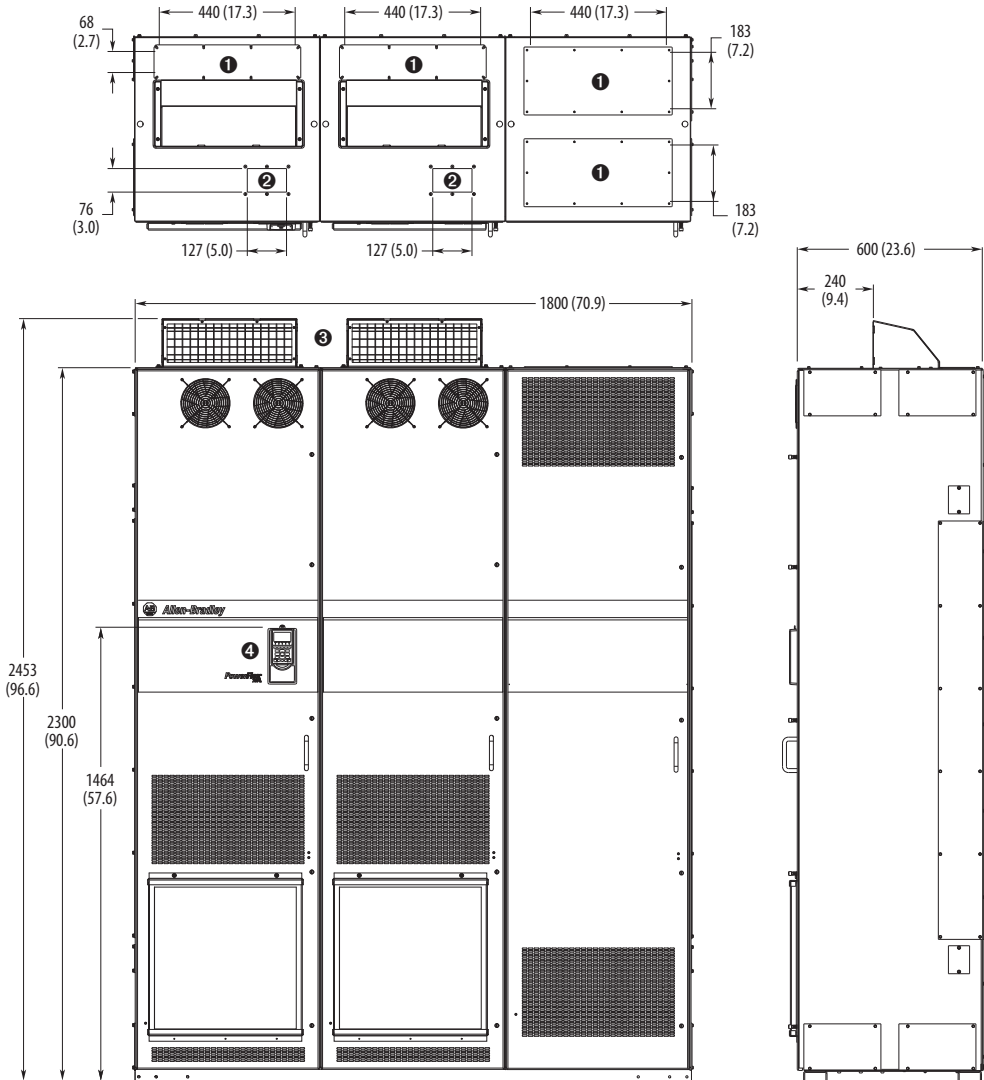

No.	Description
1	Power wiring conduit plates.
2	Control wiring conduit plates.
3	Shown with optional hood (20-750-HOOD1-F8). If hood is not used, allow sufficient top clearance for proper airflow. See page 71 .
4	Optional HIM.

Frame

Type

Approximate Dimensions – mm (in.)

- 9** MCC Style Cabinet with Cabinet Option Bay, 600 mm (23.6 in.) Deep
- IP20, NEMA/UL Type 1 Enclosure Code L (AC Input)
- Enclosure Codes P, W (DC Input)

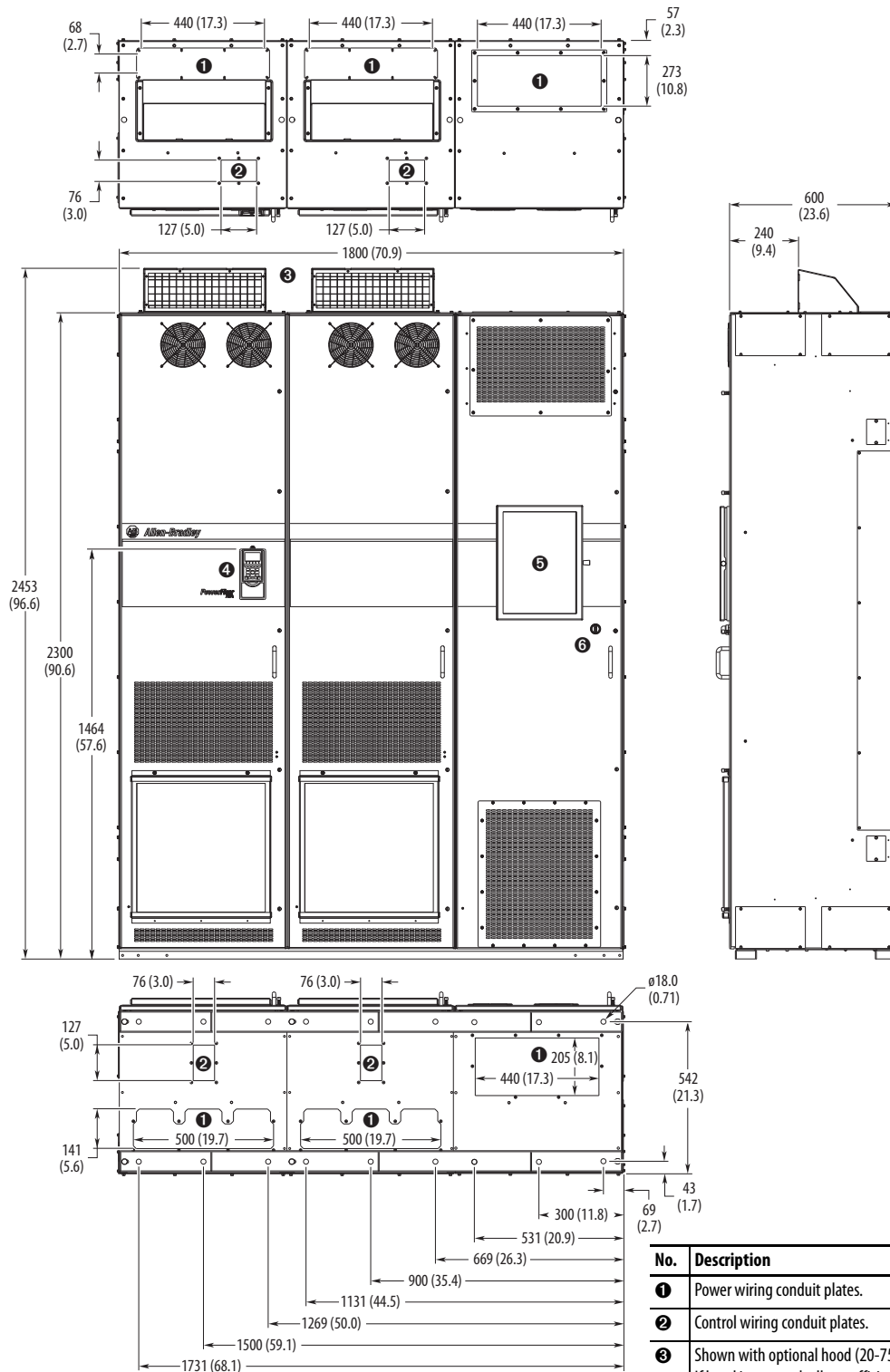

No.	Description
1	Power wiring conduit plates.
2	Control wiring conduit plates.
3	Shown with optional hood (20-750-HOOD1-F8). If hood is not used, allow sufficient top clearance for proper airflow. See page 71 .
4	Optional HIM.
5	Option bay disconnect switch access door.
6	Interlock override switch.

Frame

Type

Approximate Dimensions – mm (in.)

- 9 MCC Style Cabinet with Cabinet Option Bay and Wiring Bay, 600 mm (23.6 in.) Deep
- IP20, NEMA/UL Type 1 Enclosure Codes L, P, W

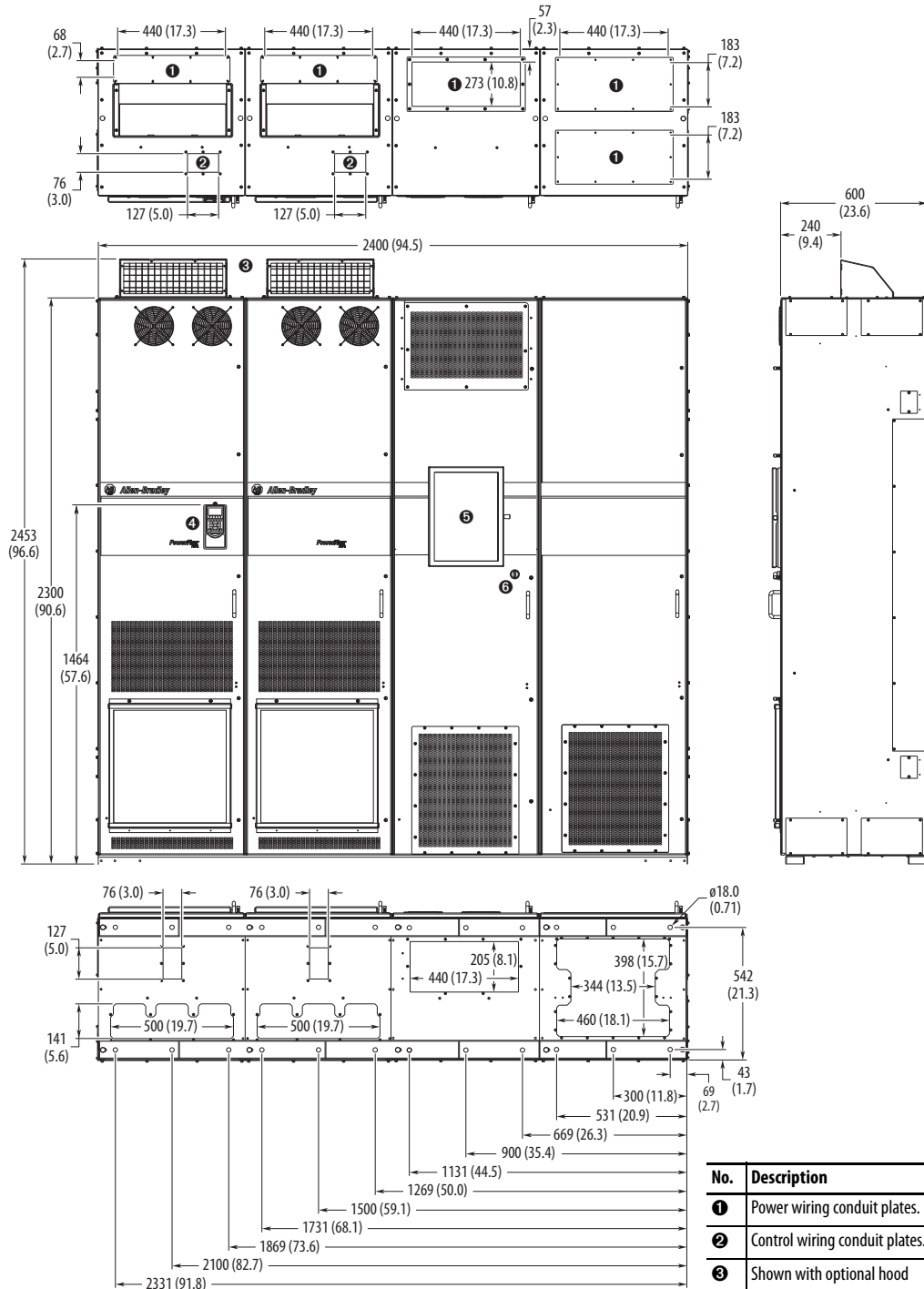

No.	Description
1	Power wiring conduit plates.
2	Control wiring conduit plates.
3	Shown with optional hood (20-750-HOOD1-F8). If hood is not used, allow sufficient top clearance for proper airflow. See page 71 .
4	Optional HIM.
5	Option bay disconnect switch access door.
6	Interlock override switch.

Frame

Type

Approximate Dimensions – mm (in.)

- 9 MCC Style Cabinet,
800 mm (31.5 in.)
Deep
- IP20, NEMA/UL Type 1
Enclosure Code L
(AC Input)
- Enclosure Codes P, W
(DC Input)

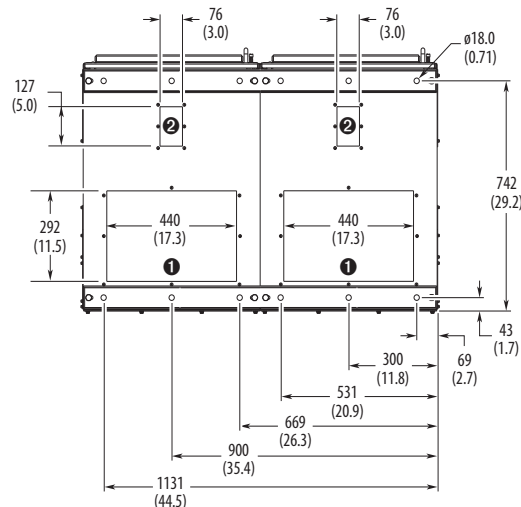
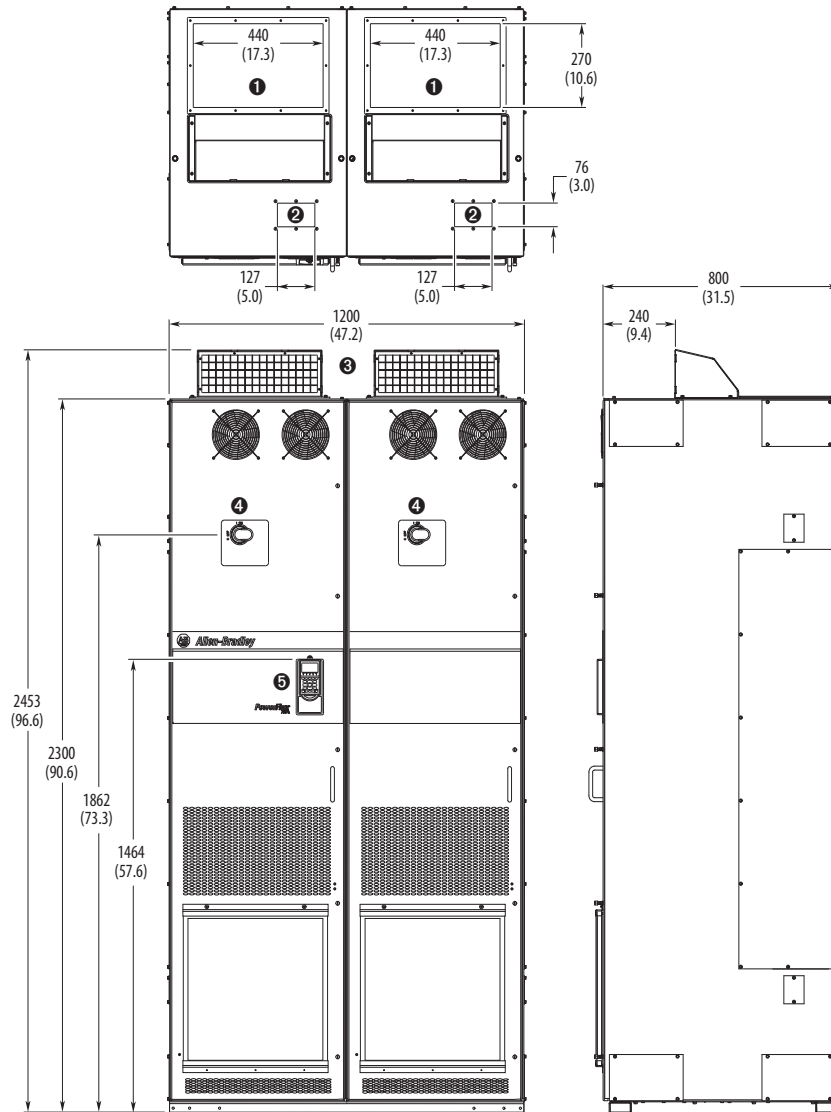

No.	Description
1	Power wiring conduit plates.
2	Control wiring conduit plates.
3	Shown with optional hood (20-750-HOOD1-F8). If hood is not used, allow sufficient top clearance for proper airflow. See page 71 .
4	Disconnect switches - Common DC Input drives.
5	Optional HIM.

Frame

Type

Approximate Dimensions – mm (in.)

- 9 MCC Style Cabinet with Wiring Bay, 800 mm (31.5 in.) Deep
- IP20, NEMA/UL Type 1
- Enclosure Code L (AC Input)
- Enclosure Codes P, W (DC Input)

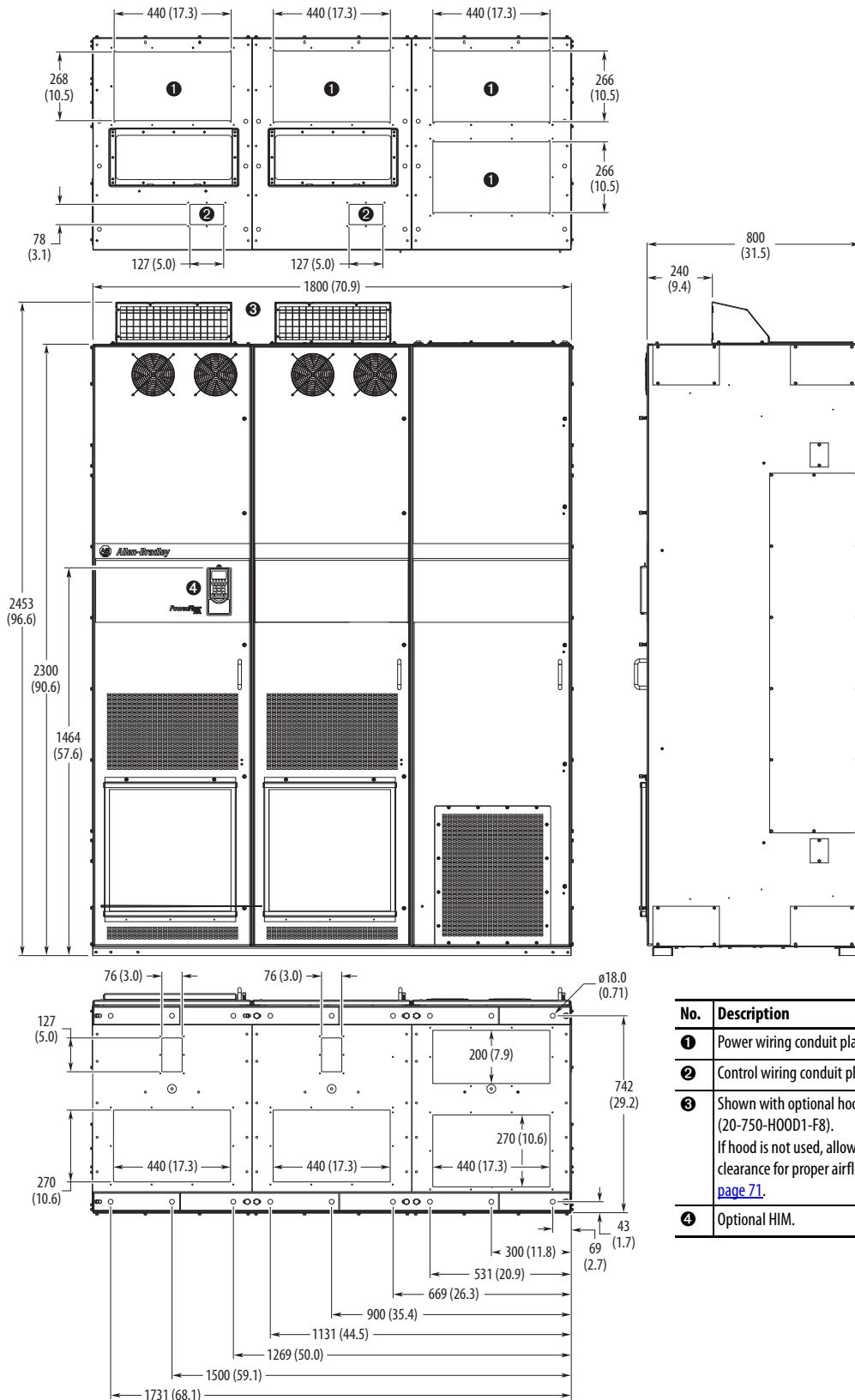

No.	Description
1	Power wiring conduit plates.
2	Control wiring conduit plates.
3	Shown with optional hood (20-750-HOOD1-F8). If hood is not used, allow sufficient top clearance for proper airflow. See page 71.
4	Optional HIM.

Frame

Type

Approximate Dimensions – mm (in.)

- 9 MCC Style Cabinet with Cabinet Option Bay, 800 mm (31.5 in.) Deep
- IP20, NEMA/UL Type 1 Enclosure Code L (AC Input)
- Enclosure Codes P, W (DC Input)

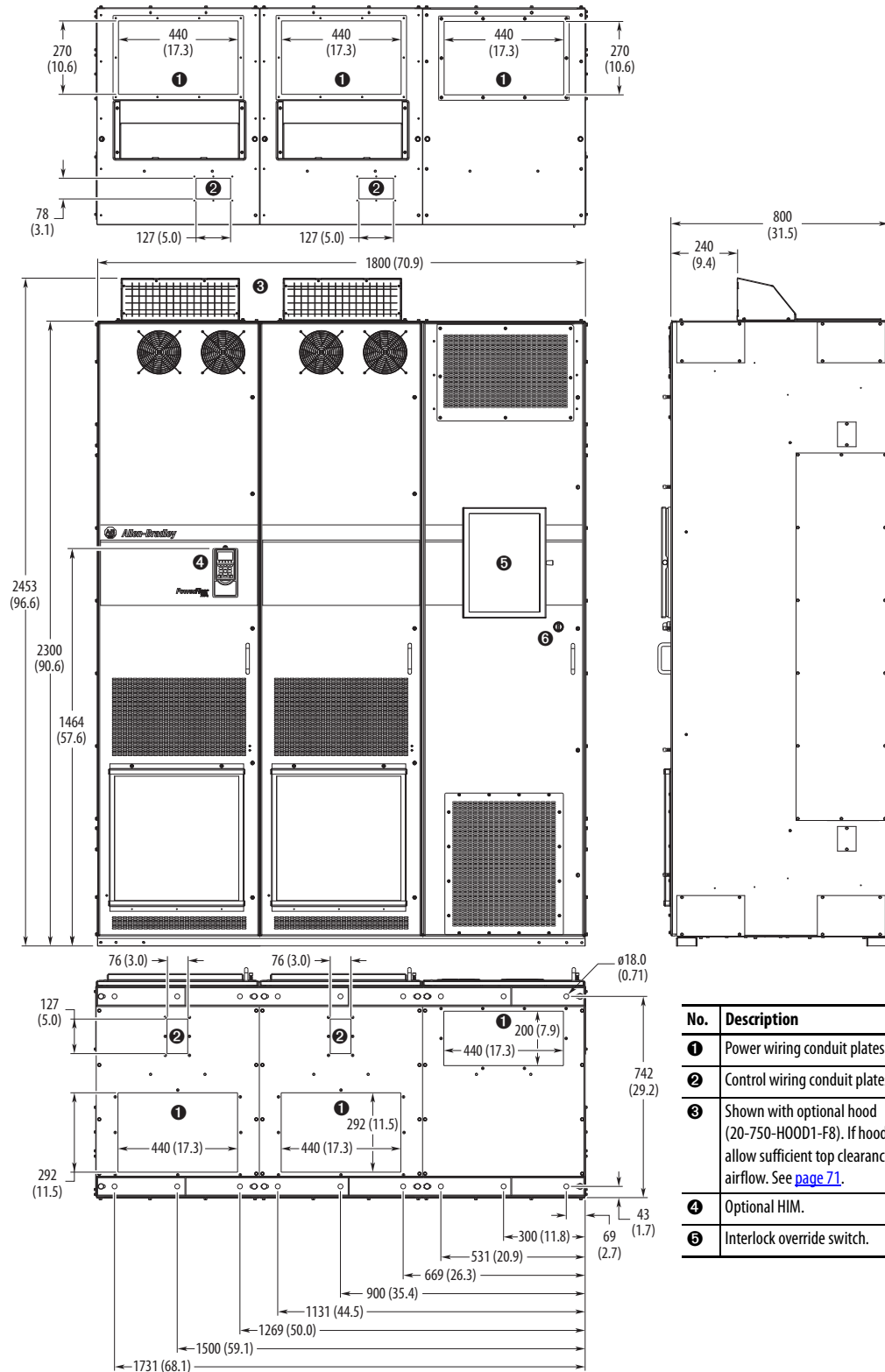

No.	Description
1	Power wiring conduit plates.
2	Control wiring conduit plates.
3	Shown with optional hood (20-750-HOOD1-F8). If hood is not used, allow sufficient top clearance for proper airflow. See page 71 .
4	Optional HIM.
5	Interlock override switch.

Frame

Type

Approximate Dimensions – mm (in.)

- 9 MCC Style Cabinet with Cabinet Option Bay and Wiring Bay, 800 mm (31.5 in.) Deep
- IP20, NEMA/UL Type 1 Enclosure Code L (AC Input)
- Enclosure Codes P, W (DC Input)

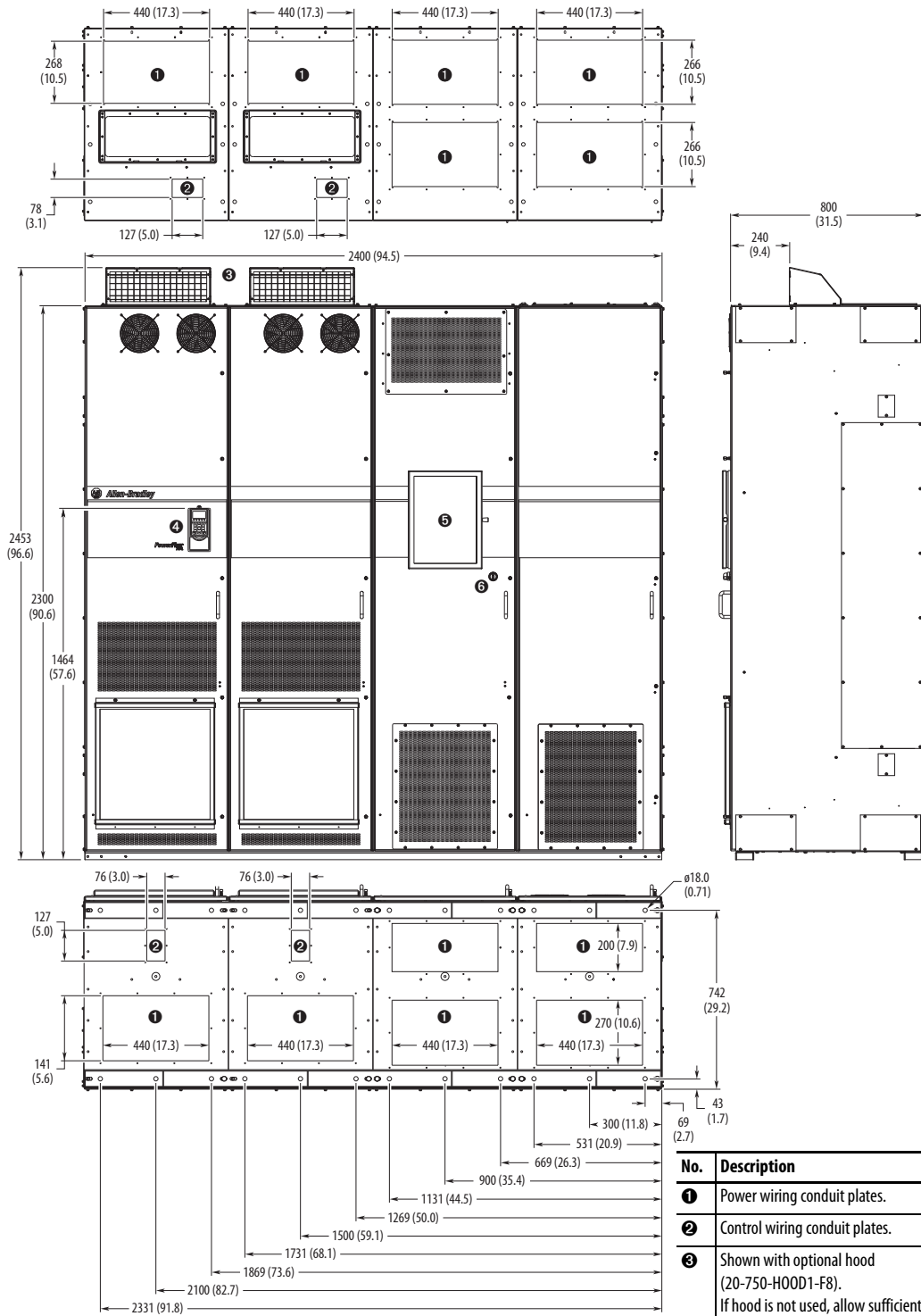

No.	Description
1	Power wiring conduit plates.
2	Control wiring conduit plates.
3	Shown with optional hood (20-750-HOOD1-F8). If hood is not used, allow sufficient top clearance for proper airflow. See page 71 .
4	Optional HIM.
5	Option bay disconnect switch access door.
6	Interlock override switch.

Frame

Type

Approximate Dimensions – mm (in.)

- 9 MCC Style Cabinet,
800 mm (31.5 in.)
Deep
- IP54, NEMA 12
Enclosure Codes K, Y
(DC Input)
- IP54, UL Type 12
Enclosure Code J
(AC Input)

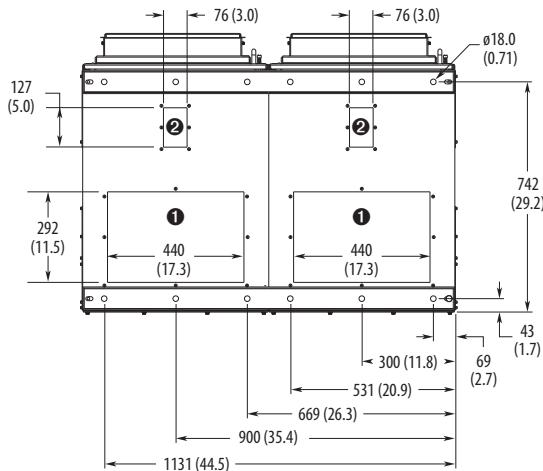
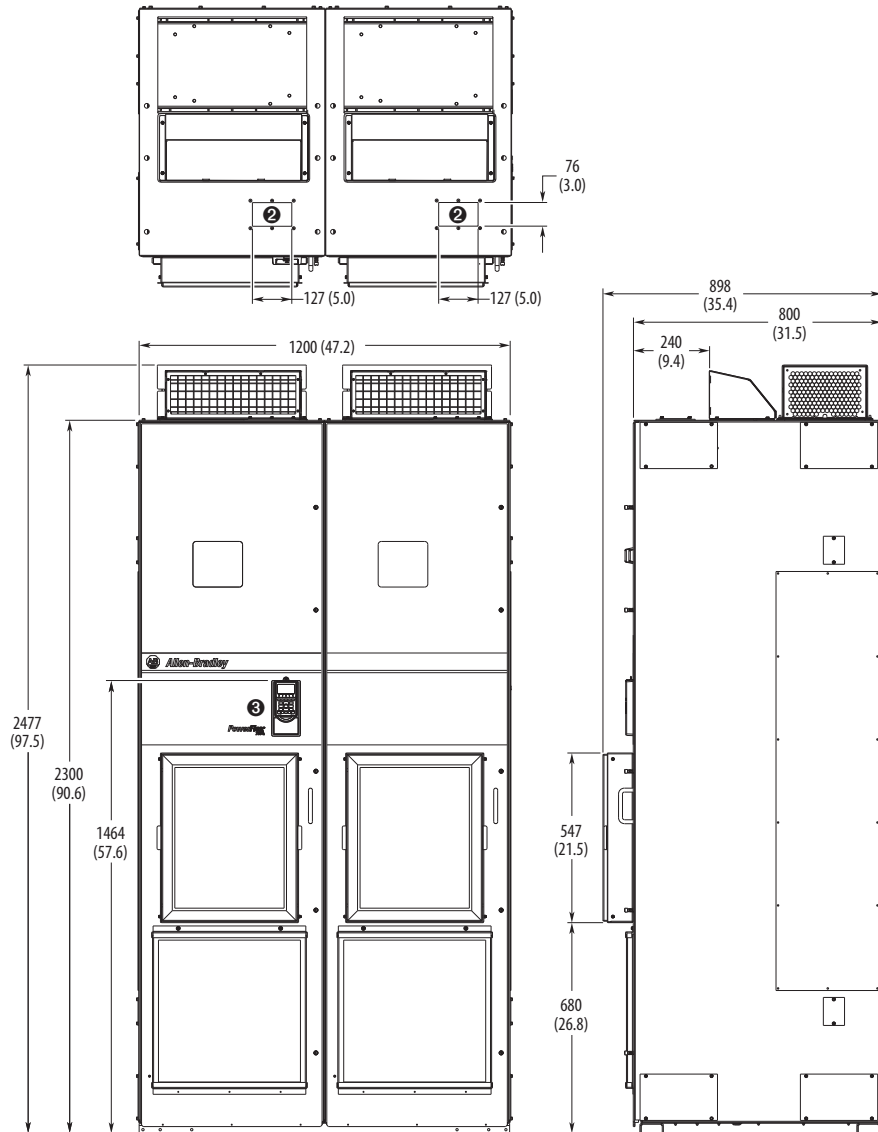

No.	Description
①	Power wiring conduit plates.
②	Control wiring conduit plates.
③	Optional HIM.

Frame

Type

Approximate Dimensions – mm (in.)

- 9 MCC Style Cabinet with Wiring Bay, 800 mm (31.5 in.) Deep
- IP54, NEMA 12 Enclosure Codes K, Y
- IP54, UL Type 12 Enclosure Code J

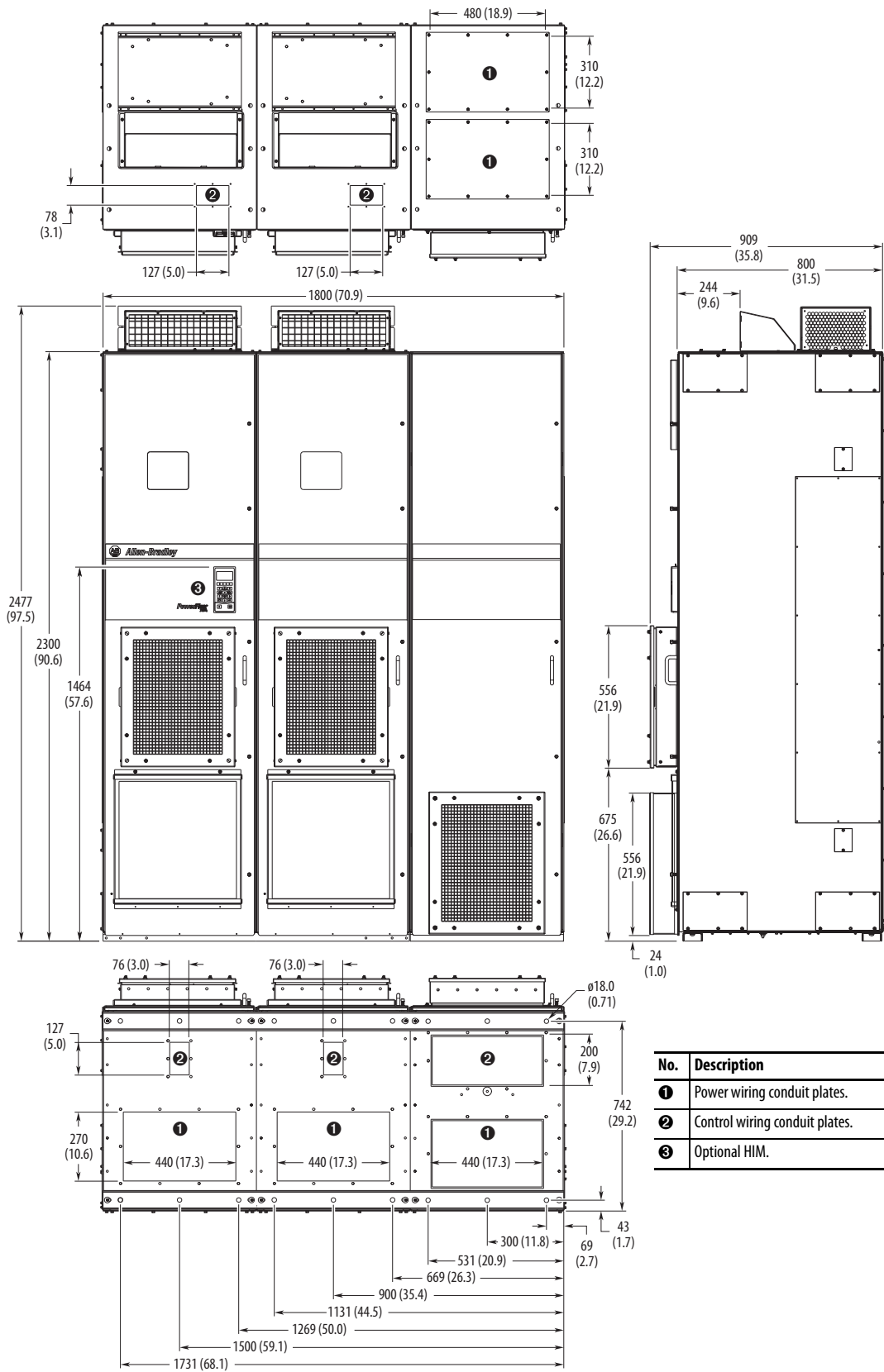

No.	Description
1	Power wiring conduit plates.
2	Control wiring conduit plates.
3	Optional HIM.

Frame

Type

Approximate Dimensions – mm (in.)

- 9 MCC Style Cabinet with Cabinet Option Bay, 800 mm (31.5 in.) Deep
- IP54, NEMA 12 Enclosure Codes K, Y
- IP54, UL Type 12 Enclosure Code J

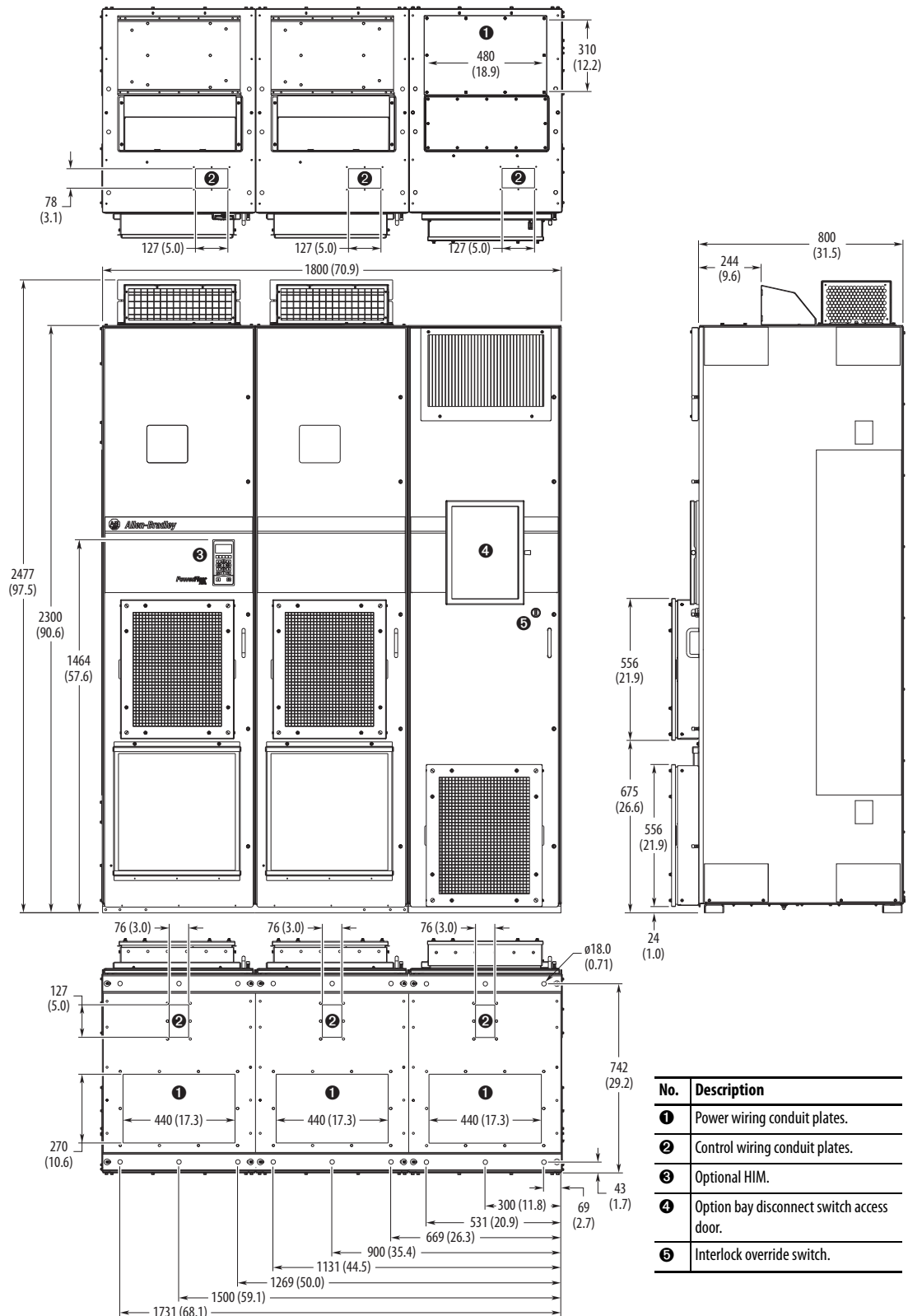

No.	Description
1	Power wiring conduit plates.
2	Control wiring conduit plates.
3	Optional HIM.
4	Option bay disconnect switch access door.
5	Interlock override switch.

Frame

Type

Approximate Dimensions – mm (in.)

- 9 MCC Style Cabinet with Cabinet Option Bay and Wiring Bay, 800 mm (31.5 in.) Deep
- IP54, NEMA 12 Enclosure Codes K, Y
- IP54, UL Type 12 Enclosure Code J

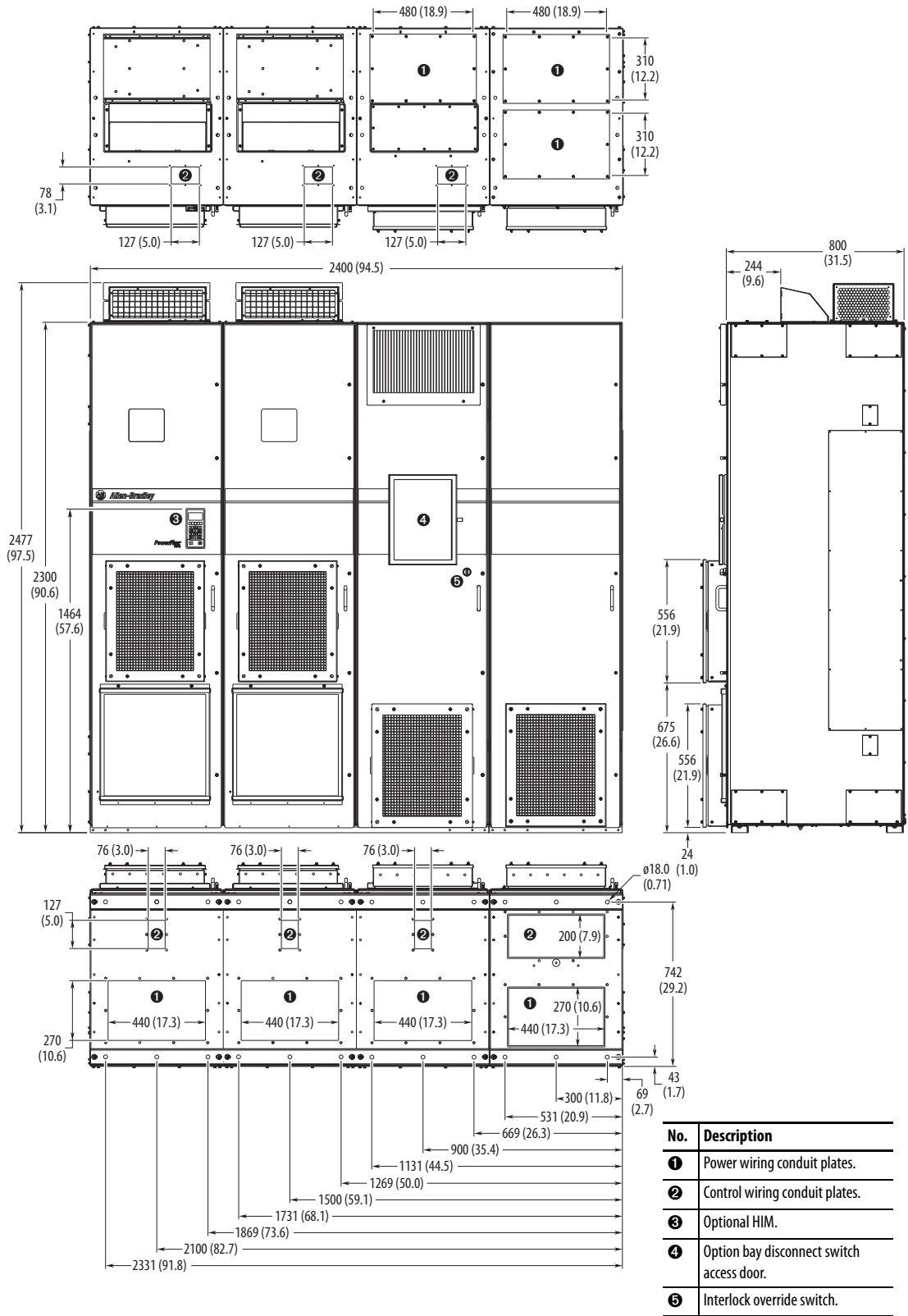

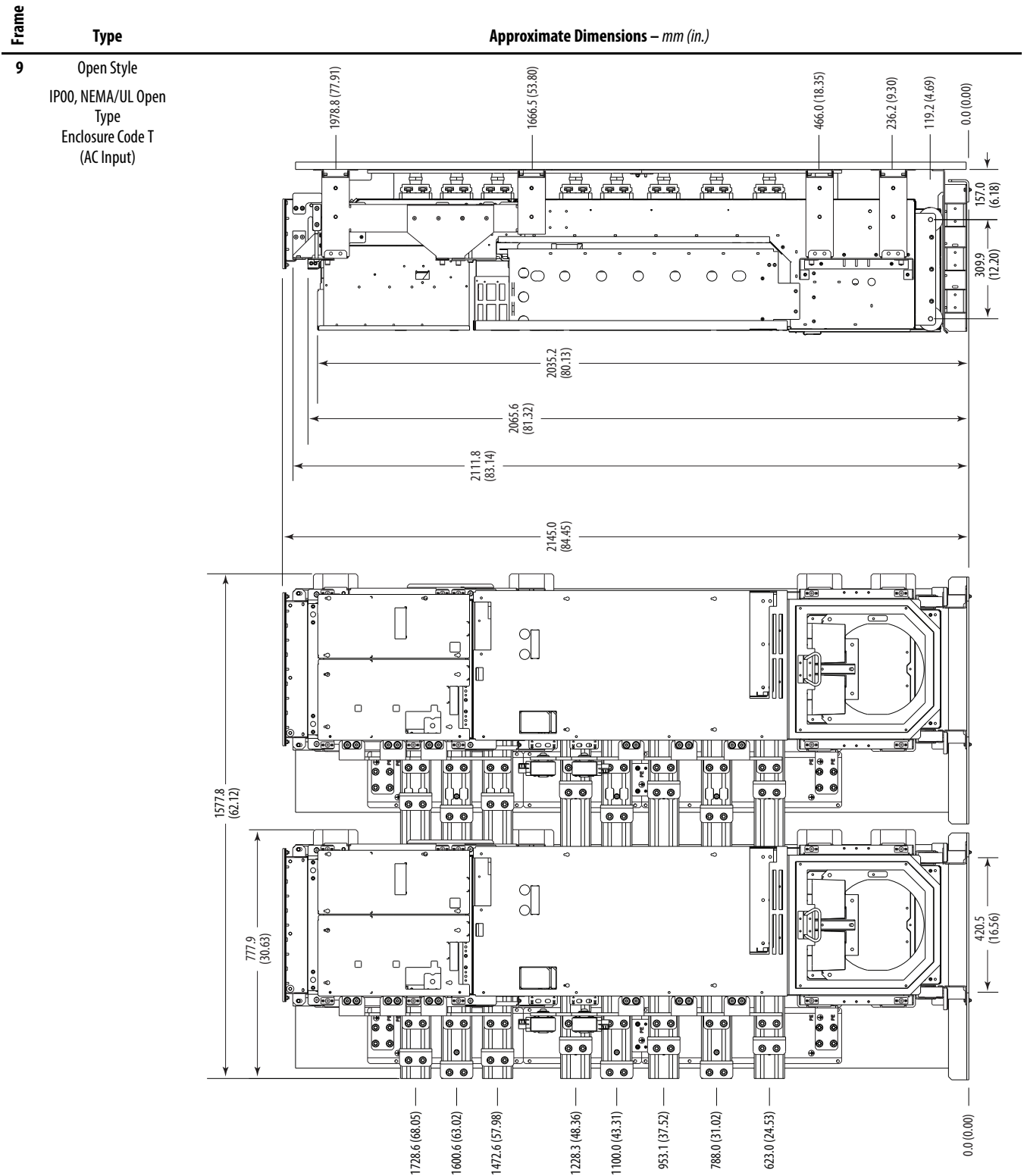

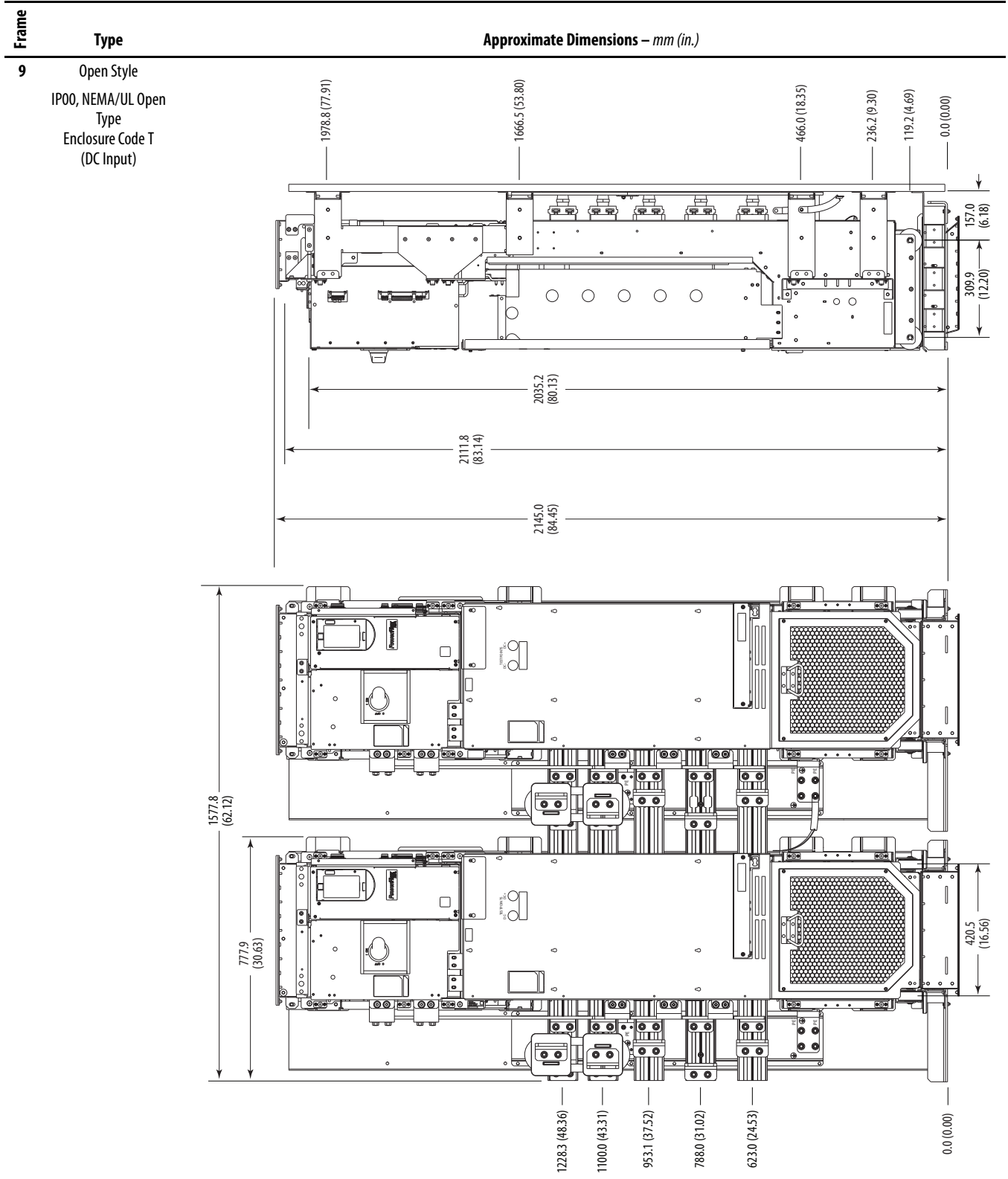

Frame

Type

Approximate Dimensions – mm (in.)

- 10** MCC Style Cabinet,
600 mm (23.6 in.)
Deep
IP20, NEMA/UL Type 1
Enclosure Code B

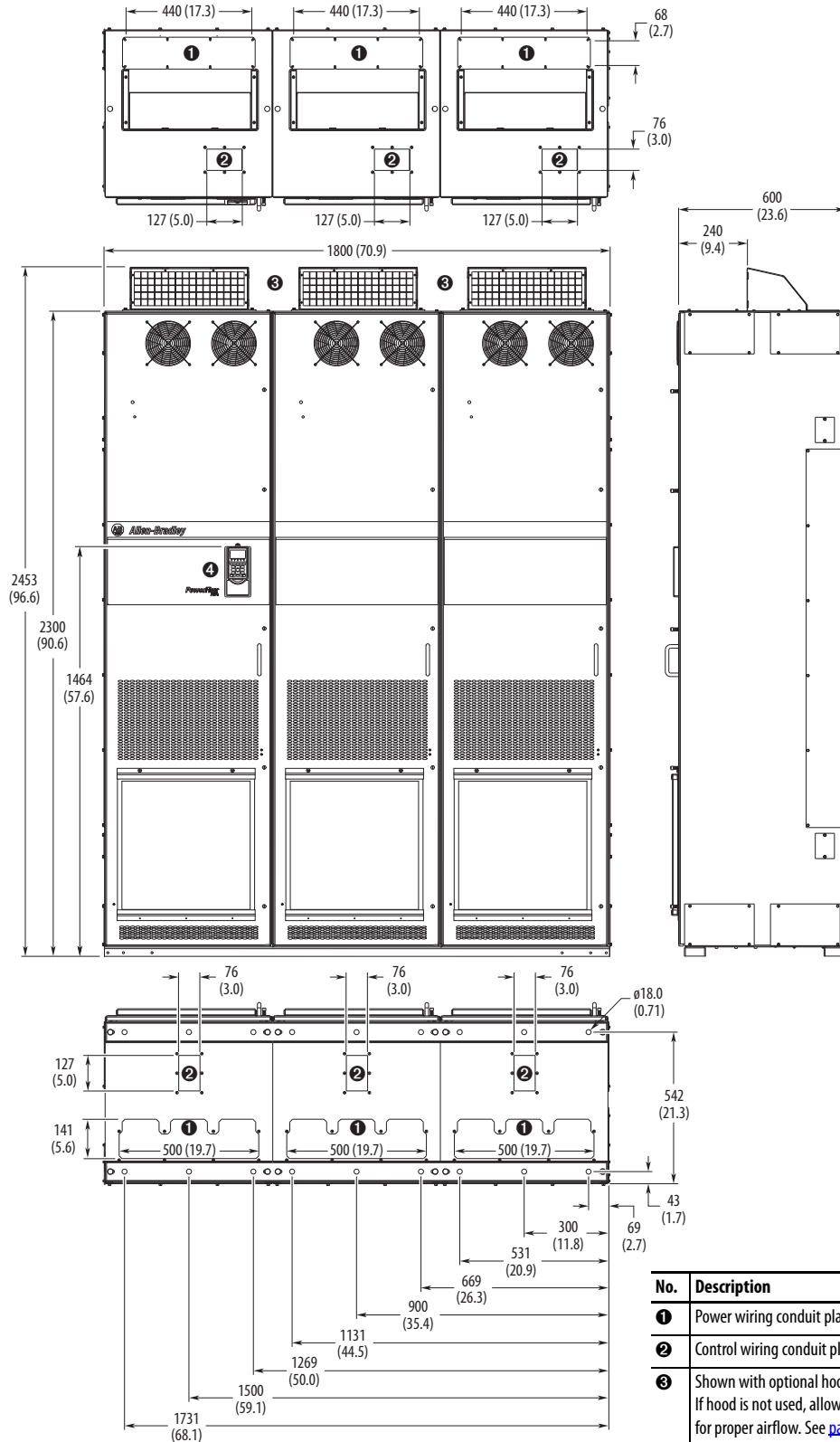

No.	Description
1	Power wiring conduit plates.
2	Control wiring conduit plates.
3	Shown with optional hood (20-750-HOOD1-F8). If hood is not used, allow sufficient top clearance for proper airflow. See page 71.
4	Optional HIM.

Frame

Type

Approximate Dimensions – mm (in.)

- 10** MCC Style Cabinet,
800 mm (31.5 in.)
Deep
- IP20, NEMA/UL Type 1
Enclosure Code L
(AC Input)
- Enclosure Codes P, W
(DC Input)

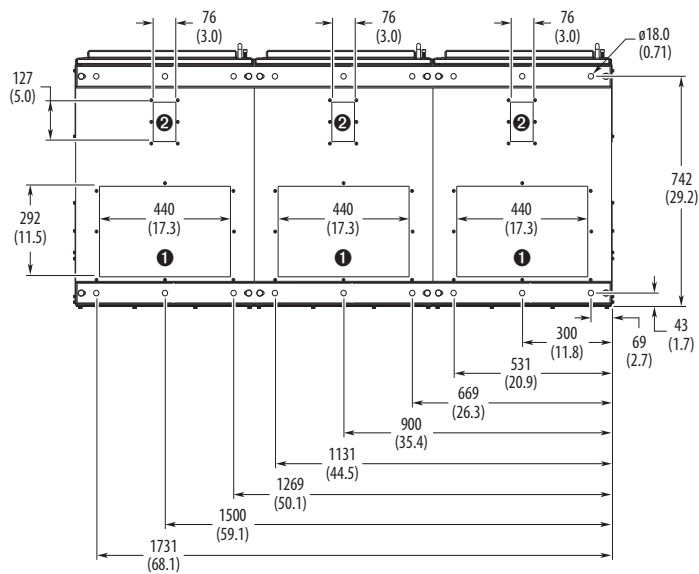
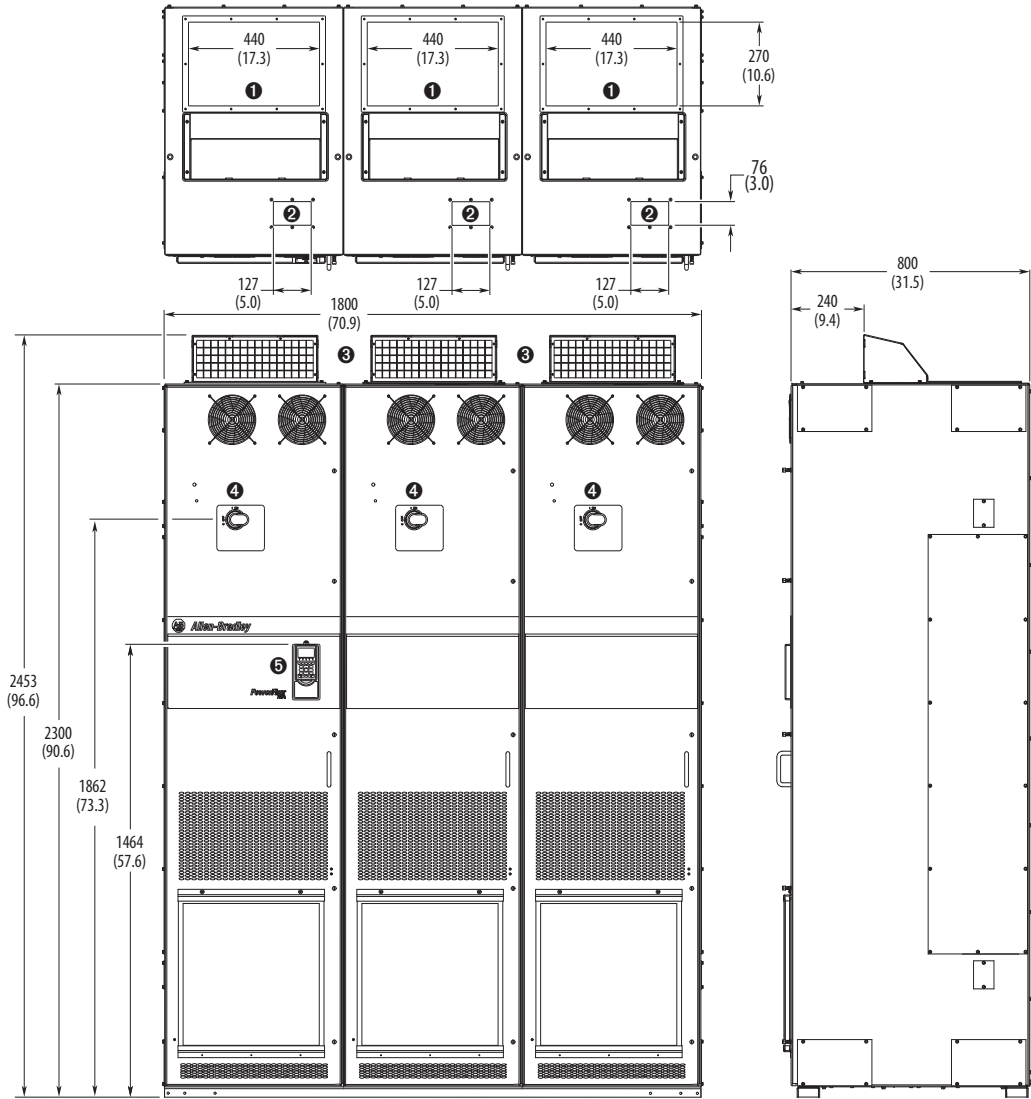

No.	Description
1	Power wiring conduit plates.
2	Control wiring conduit plates.
3	Shown with optional hood (20-750-HOOD1-F8). If hood is not used, allow sufficient top clearance for proper airflow. See page 71 .
4	Disconnect switches - Common DC Input drives.
5	Optional HIM.

Frame

Type

Approximate Dimensions – mm (in.)

- 10** MCC Style Cabinet
 800 mm (31.5 in.)
 Deep
 IP54, NEMA 12
 Enclosure Codes K, Y
 (DC Input)
 IP54, UL Type 12
 Enclosure Code J
 (AC Input)

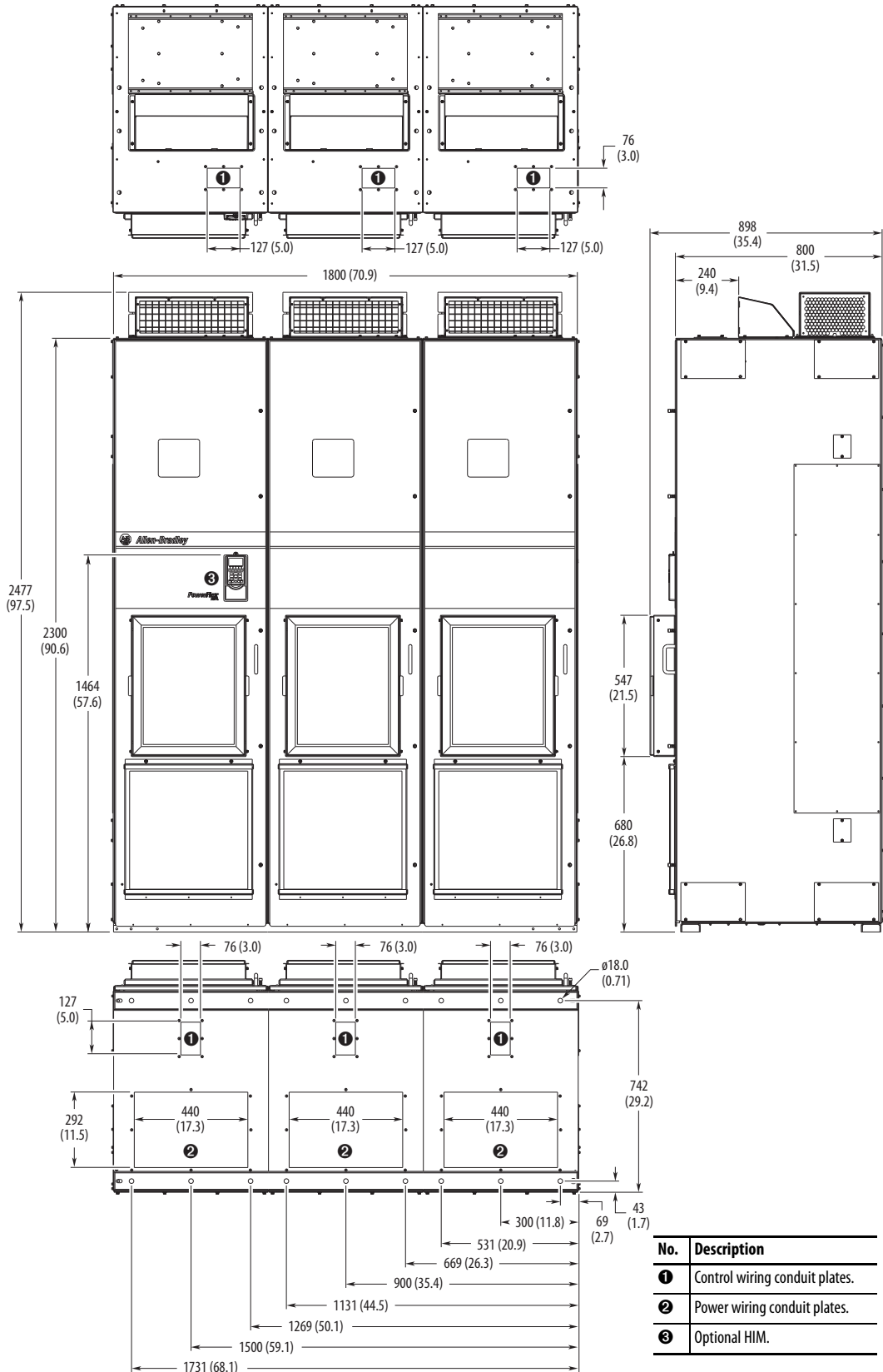

No.	Description
①	Control wiring conduit plates.
②	Power wiring conduit plates.
③	Optional HIM.

Frame

Type

Approximate Dimensions – mm (in.)

10 Open Style
 IP00, NEMA/UL Open
 Type
 Enclosure Code T
 (AC Input)

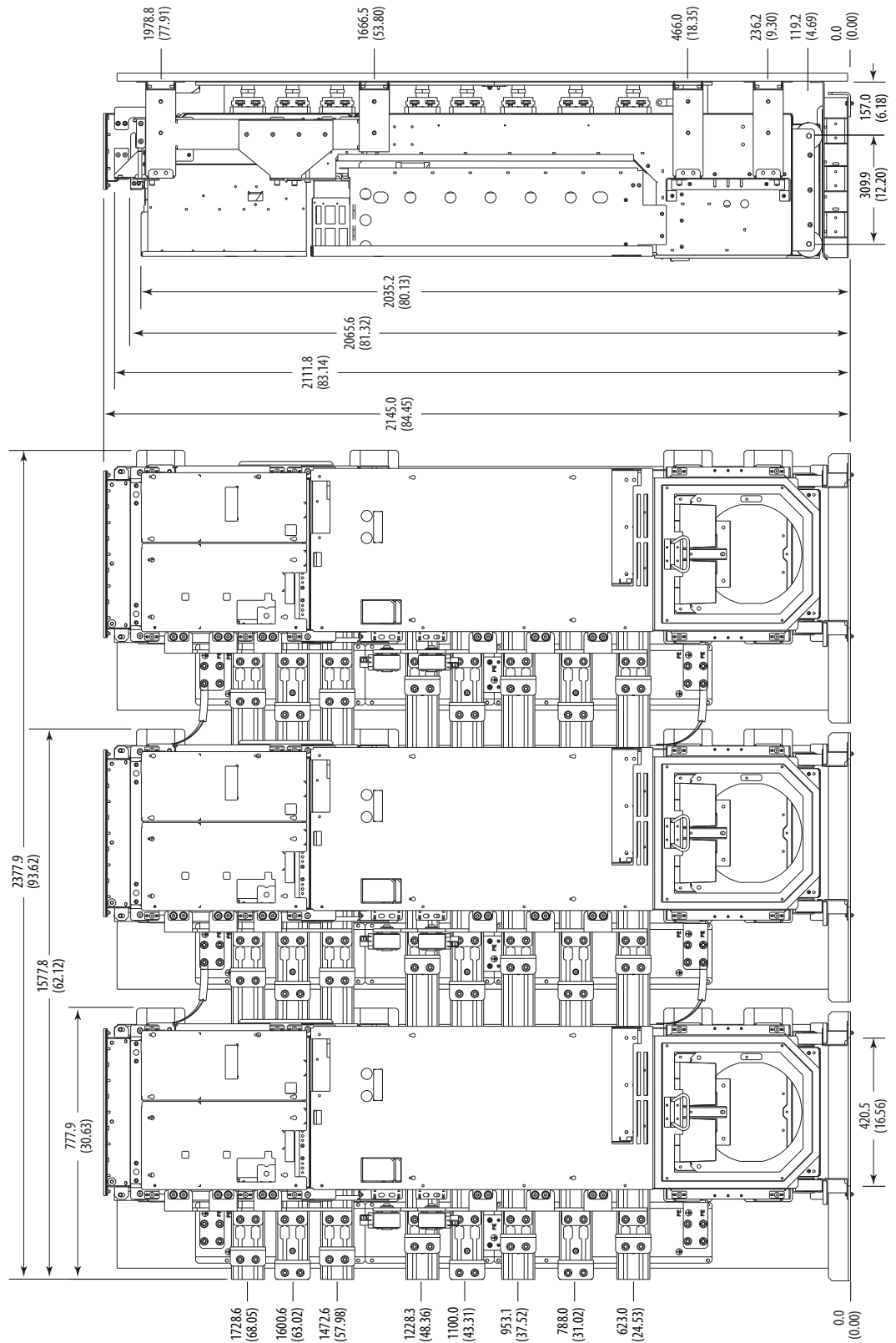

Frame

Type

Approximate Dimensions – mm (in.)

10 Open Style
 IP00, NEMA/UL Open
 Type
 Enclosure Code T
 (DC Input)

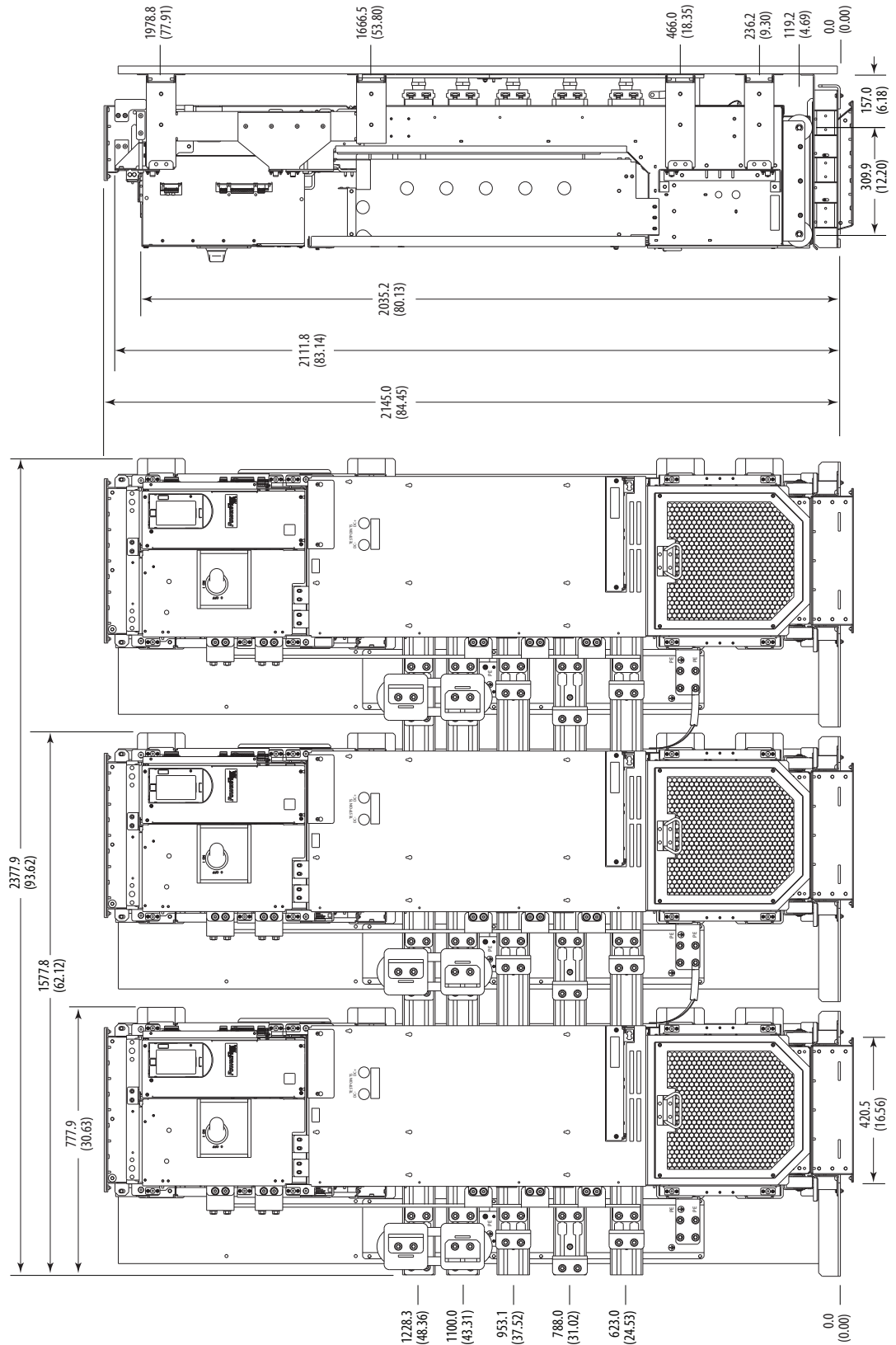

Frame	Type	Approximate Dimensions – mm (in.)			
1...5	NEMA/UL Type 1 Kit	Frame 4 Shown			
Frame	A	B	C	D	
1	215.4 (8.48)	458.8 (18.06)	–	–	
2	222.2 (8.75)	497.1 (19.57)	117.7 (4.63)	38.0 (1.50)	
3	223.1 (8.78)	530.1 (20.87)	154.7 (6.09)	38.0 (1.50)	
4	222.7 (8.77)	564.4 (22.22)	154.7 (6.09)	40.0 (1.57)	
5	222.7 (8.77)	665.4 (26.20)	155.0 (6.10)	55.0 (2.17)	

Important: NEMA Type 1 Kits (20-750-NEMA-Fx) do not change the mounting dimensions.

6 NEMA/UL Type 1 Kit

Frame	Type	Approximate Dimensions – mm (in.)
-------	------	-----------------------------------

1...5 NEMA/UL Type 1 Bottom View

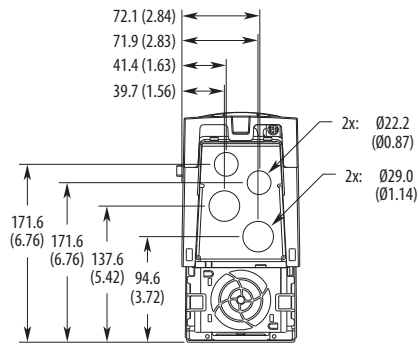

Frame 1

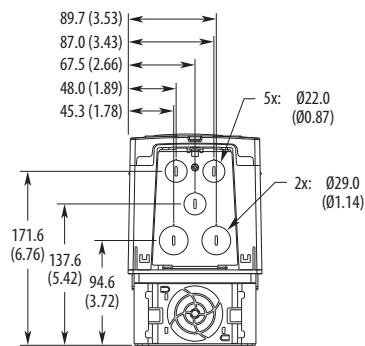

Frame 2

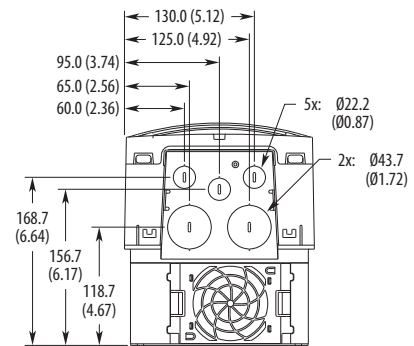

Frame 3

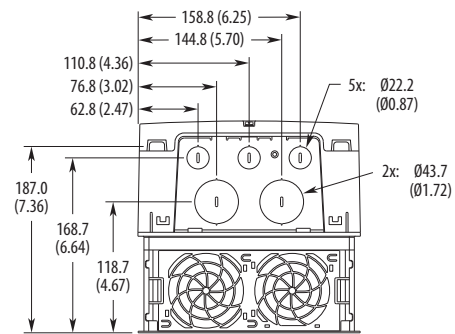

Frame 4

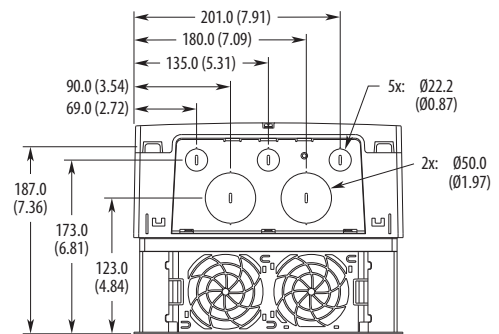

Frame 5

Frame **Type** **Approximate Dimensions – mm (in.)**

1...7 EMC Plate and Cores Kit

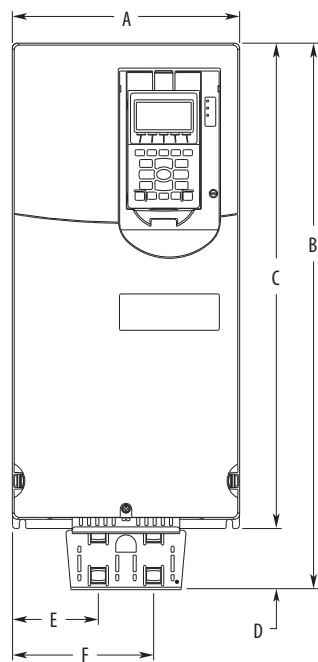

Frame 4 Shown

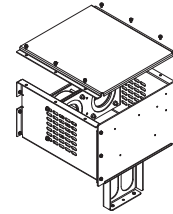

Frame 6 Shown (Kit Only)

Enclosures are shown without venting. Supplied enclosures have proper venting.

Frame	A	B	C	D	E	F
1	110.0 (4.33)	478.8 (18.85)	400.5 (15.77)	78.3 (3.08)	37.4 (1.47)	73.4 (2.89)
2	134.5 (5.30)	485.9 (19.13)	424.2 (16.70)	61.7 (2.43)	43.5 (1.71)	79.5 (3.13)
3	190.0 (7.48)	514.0 (20.24)	454.0 (17.87)	60.0 (2.36)	74.0 (2.91)	116.0 (4.57)
4	222.0 (8.74)	533.7 (21.01)	474.0 (18.66)	59.7 (2.35)	84.0 (3.31)	138.0 (5.43)
5	270.0 (10.63)	609.7 (24.00)	550.0 (21.65)	59.7 (2.35)	77.8 (3.06)	191.8 (7.55)

Important: EMC Kits (20-750-EMCx-Fx) do not change the mounting dimensions. See the PowerFlex 750-Series EMC Plate and Core(s) Installation Instructions, publication [750-IN006](#), for detailed information on kit installation.

Frame	Type	Approximate Dimensions – mm (in.)
-------	------	-----------------------------------

- | | | |
|---|---|--|
| – | Power Option Cabinet
600 and 800 mm Wide | |
|---|---|--|

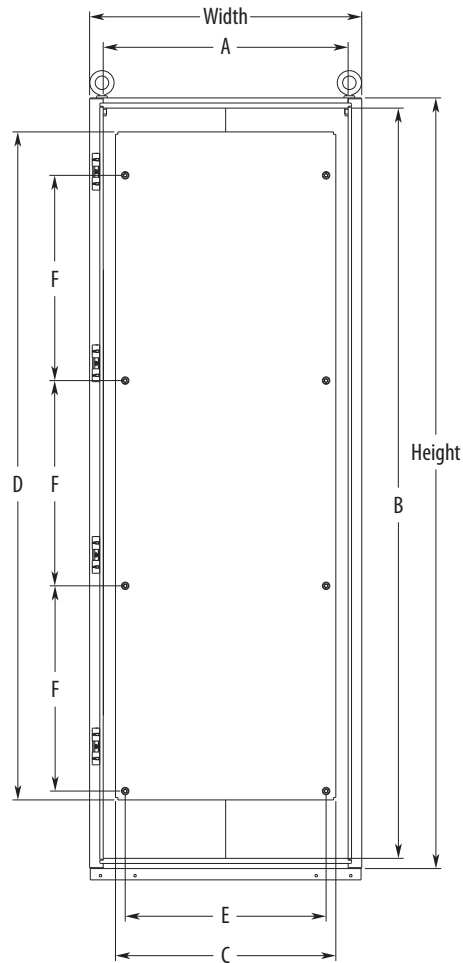

Cat. No.	Height	Width	Depth	A	B	C	D	E	F
20-750-PBAY-66	2265.5 (89.2)	600 (23.6)	600 (23.6)	520 (20.5)	2205.5 (86.8)	447.7 (17.6)	1963.7 (77.3)	390.5 (15.4)	603.3 (23.8)
20-750-PBAY-68	2265.5 (89.2)	600 (23.6)	800 (31.5)	520 (20.5)	2205.5 (86.8)	447.7 (17.6)	1963.7 (77.3)	390.5 (15.4)	603.3 (23.8)
20-750-PBAY-86	2265.5 (89.2)	800 (31.5)	600 (23.6)	720 (28.3)	2205.5 (86.8)	647.7 (25.5)	1963.7 (77.3)	590.5 (23.2)	603.3 (23.8)
20-750-PBAY-88	2265.5 (89.2)	800 (31.5)	800 (31.5)	720 (28.3)	2205.5 (86.8)	647.7 (25.5)	1963.7 (77.3)	590.5 (23.2)	603.3 (23.8)

See the PowerFlex 750-Series Power Option Cabinets Installation Instructions, publication [750-IN030](#) for details.

Frame	Type	Approximate Dimensions – mm (in.)
-------	------	-----------------------------------

– Power Option Cabinet
1200 mm Wide

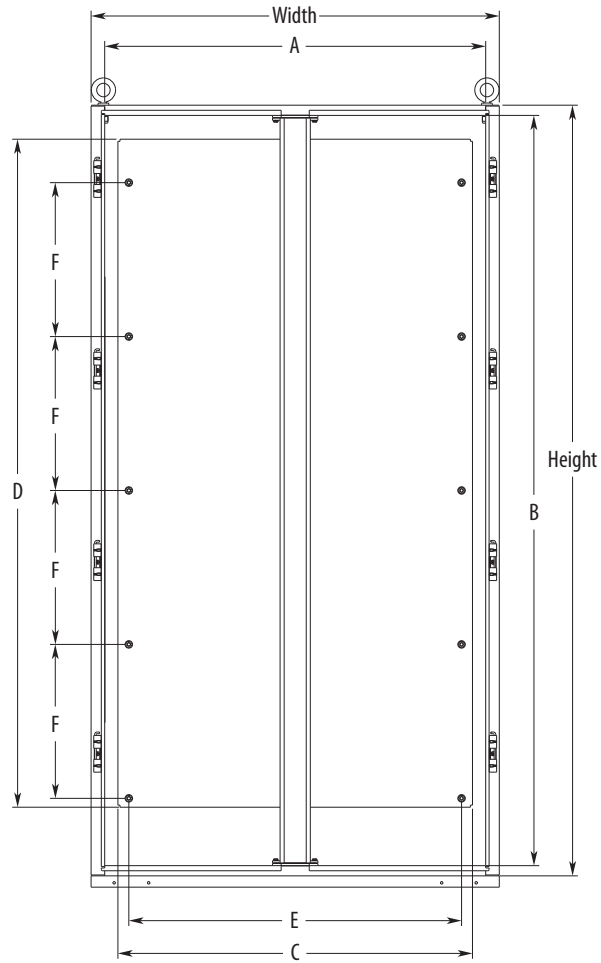

Cat. No.	Height	Width	Depth	A	B	C	D	E	F
20-750-PBAY-126	2265.5 (89.2)	1200 (47.2)	600 (23.6)	1120 (44.1)	2205.5 (86.8)	1042.3 (41.0)	1963.7 (77.3)	978.1 (38.5)	452.5 (17.8)
20-750-PBAY-128	2265.5 (89.2)	1200 (47.2)	800 (31.5)	1120 (44.1)	2205.5 (86.8)	1042.3 (41.0)	1963.7 (77.3)	978.1 (38.5)	452.5 (17.8)

See the PowerFlex 750-Series Power Option Cabinets Installation Instructions, publication [750-IN030](#) for details.

Drive Options

Human Interface Modules



Blank Plate

20-HIM-A6

20-HIM-C6S

Description	Cat. No.
No HIM (Blank Plate)	20-HIM-A0
Enhanced, LCD, Full Numeric, Handheld/Local, NEMA Type 1	20-HIM-A6
Enhanced, LCD, Full Numeric, IP66 NEMA Type 4X/12 (for indoor use only) ⁽¹⁾	20-HIM-C6S

(1) Includes a 3 m (9.8 ft) 1202-C30 interface cable for connection to drive.

Specifications - Human Interface Modules

	20-HIM-A6 ⁽¹⁾	20-HIM-C6S ⁽¹⁾
Drive Protocol: Data Rates:	Drive Peripheral Interface (DPI) 125 Kbps or 500 Kbps	
Consumption Drive (DPI):	140 mA at 12V DC supplied by the Host Drive	
Dimensions - H x W x D 20-HIM-A6: 20-HIM-C6S:	116 x 70 x 16 mm (4.57 x 2.75 x 0.63 in.) 180 x 93 x 25 mm (7.08 x 3.66 x 0.98 in.)	
Weight:	91 g (3.2 oz)	173 g (5.7 oz)
Temperature Operating: Storage:	0...50 °C (32...122 °F) -40...85 °C (-40...185 °F)	
Relative Humidity:	5...95% non-condensing	
Atmosphere:	Important: The module must not be installed in an area where the ambient atmosphere contains volatile or corrosive gas, vapors or dust. If the module is not going to be installed for a period of time, it must be stored in an area where it will not be exposed to a corrosive atmosphere.	
UV Radiation	The HIM is not UV rated.	
Vibration Operating: Non-Operating:	2.5 G at 5...2000 Hz 5 G at 5...2000 Hz	
Shock Operating: Non-Operating:	30 G peak acceleration, 11 (±1) ms pulse width 50 G peak acceleration, 11 (±1) ms pulse width	
UL c-UL CE C-Tick FCC ID IC	UL508C CAN / CSA C22.2 No. 14 EN61800-3 EN61800-3 — —	

(1) NOTE: This is a product of category C2 according to IEC 61800-3. In a domestic environment, this product may cause radio interference in which case supplementary mitigation measures may be required.

Human Interface Module Accessories

Description	Cat. No.
Bezel Kit for LCD HIMs, NEMA Type 1 ⁽¹⁾	20-HIM-B1
PowerFlex HIM Interface Cable, 1 m (39 in.) ⁽²⁾	20-HIM-H10
Comm Option Cable Kit (Male-Male) 0.33 m (1.1 ft) 1 m (3.3 ft) 3 m (9.8 ft) 9 m (29.5 ft)	1202-C03 1202-C10 1202-C30 1202-C90
Cable Kit (Male-Female) ⁽³⁾ 0.33 m (1.1 ft) 1 m (3.3 ft) 3 m (9.8 ft) 9 m (29.5 ft)	1202-H03 1202-H10 1202-H30 1202-H90
DPI Cable Kit with Connectors, Tools and 100 m (328 ft) Cable	1202-CBL-KIT-100M
DPI Cable Connector Kit	1202-TB-KIT-SET
DPI/SCANport™ One to Two Port Splitter Cable	1203-S03

(1) Includes a 3 m (9.8 ft) 1202-C30 interface cable for connection to drive.

(2) Required only when HIM is used as handheld or remote.

(3) Required in addition to 20-HIM-H10 for distances up to a total maximum of 10 m (32.8 ft).

Communication Option Kits and Accessories

Description (see page 131 for specifications)	Cat. No.
BACnet/IP Option Module	20-750-BNETIP
Coaxial ControlNet™ Option Module	20-750-CNETH
ControlNet Communication Adapter (Coax)	20-COMM-C ⁽³⁾
DeviceNet™ Option Module	20-750-DNET
DeviceNet Communication Adapter	20-COMM-D ⁽³⁾
Dual-port EtherNet/IP Option Module	20-750-ENETR
EtherNet/IP™ Communication Adapter	20-COMM-E ⁽³⁾
HVAC Communication Adapter (Only Modbus RTU can be used)	20-COMM-H ⁽³⁾
CANopen® Communication Adapter	20-COMM-K ⁽³⁾
LonWorks® Communication Adapter	20-COMM-L ⁽³⁾
Modbus/TCP Communication Adapter	20-COMM-M ⁽³⁾
Profibus DPV1 Option Module	20-750-PBUS
Single-port Profinet I/O Option Module	20-750-PNET
Dual-port Profinet I/O Option Module	20-750-PNET2P
PROFIBUS™ DP Communication Adapter	20-COMM-P ⁽³⁾
ControlNet Communication Adapter (Fiber)	20-COMM-Q ⁽³⁾
Remote I/O Communication Adapter	20-COMM-R ⁽³⁾⁽⁴⁾
RS485 DF1 Communication Adapter	20-COMM-S ⁽³⁾
External Communications Kit Power Supply	20-XCOMM-AC-PS1
DPI External Communications Kit ⁽¹⁾	20-XCOMM-DC-BASE
External DPI I/O Option Board ⁽²⁾	20-XCOMM-IO-OPT1
Compact I/O™ Module (3 Channel)	1769-SM1
Serial Null Modem Adapter	1203-SNM
Smart Self-powered Serial Converter (RS232) includes 1203-SFC and 1202-C10 Cables	1203-SSS
Universal Serial Bus™ (USB) Converter includes 2 m USB, 20-HIM-H10 and 22-HIM-H10 Cables	1203-USB
ControlNet T-tap Straight	1786-TPS
Communication Carrier Card for PowerFlex 750-Series Frame 1 drives	20-750-20COMM-F1
Communication Carrier Card for PowerFlex 750-Series Frame 2 or higher drives	20-750-20COMM

(1) Only compatible with the following; 20-COMM-E EtherNet/IP, 20-COMM-C ControlNet (coax), 20-COMM-Q ControlNet (fiber), 20-COMM-D DeviceNet (Series B or later), 20-COMM-M Modbus/TCP.

(2) For use only with DPI External Communications Kits 20-XCOMM-DC-BASE.

(3) Requires a Communication Carrier Card (20-750-20COMM or 20-750-COMM-F1). See [page 130](#) for compatibility details.

(4) This item has [End of Life](#) status.

PowerFlex 755 System Resource Allocation

Some drive configurations that utilize certain communication options may exceed the available resources of the processor that is located on the Main Control Board. This is a consideration for PowerFlex 755 drives with Firmware revision 2.000 (or later). Refer to the PowerFlex 750-Series Programming Manual, publication [750-PM001](#) for details.

PowerFlex 750-Series Legacy Communication Options

Most legacy communication adapters (20-COMM) can be used with the PowerFlex 755. However, the restrictions stated below do apply.

Frame 1 - It is recommended that the 20-750-20COMM-F1 Communication Carrier Card only be installed in Port 4. Port 5 will not be accessible when this module is installed.

Frames 2 and larger - It is recommended that the 20-750-20COMM Communication Carrier Card be installed in Port 6. Using Port 4 or 5 will make the adjacent left port inaccessible to other option modules and may interfere with network cable connections. For details, contact Allen-Bradley Drives Technical Support.

Adapter		Accesses Ports 0...6 for I/O Connections (Implicit and Explicit Messaging)	Accesses Ports 7 and Higher (I/O, Explicit Messaging)	Supports Drive Add-on Profiles	Supports Asian- Languages ⁽⁶⁾
Cat. No.	Type				
20-COMM-B	BACnet MS/TP	Not Compatible			
20-COMM-C	ControlNet (Coax)	✓ v3.001 ⁽⁴⁾	✓ v3.001 ⁽⁴⁾	✓ ⁽⁵⁾	✓ v3.001 ⁽⁴⁾
20-COMM-D	DeviceNet	✓ ⁽²⁾	Not Compatible		
20-COMM-E	EtherNet/IP	✓ v4.001 ⁽⁴⁾	✓ v4.001 ⁽⁴⁾	✓ ⁽⁵⁾	✓ v4.001 ⁽⁴⁾
20-COMM-H	RS-485 HVAC	✓ v2.009 ⁽³⁾⁽⁴⁾	Not Compatible		
20-COMM-K	CANopen	✓ v1.001 ⁽⁴⁾			
20-COMM-L	LonWorks	✓ v1.007 ⁽⁴⁾			
20-COMM-M	Modbus/TCP	✓ v2.001 ⁽⁴⁾	✓ v2.001 ⁽⁴⁾	Not Compatible	✓ v2.001 ⁽⁴⁾
20-COMM-P	ControlNet (Fiber)	✓ v1.006 ⁽⁴⁾	✓ v1.006 ⁽⁴⁾		Not Compatible
20-COMM-Q	PROFIBUS DP	✓ v3.001 ⁽⁴⁾	✓ v3.001 ⁽⁴⁾	✓ ⁽⁵⁾	✓ v3.001 ⁽⁴⁾
20-COMM-R ⁽¹⁾	Remote I/O	✓ ⁽²⁾	Not Compatible		
20-COMM-S	RS-485 DF1	✓ ⁽²⁾			

- (1) This item has [End of Life](#) status.
- (2) Controller must be capable of reading/writing 32-bit floating point (REAL) values.
- (3) Supports all three modes of operation (RTU, P1, N2).
- (4) Requires this adapter firmware version or higher.
- (5) Requires firmware version v1.05 or higher of the drive Add-on Profiles for Studio 5000 Logix Designer® software.
- (6) Chinese, Japanese, and Korean languages are supported at the time of publication.

Environmental Specifications – Communication Modules

Temperature Operating: Storage:	-10...50 °C (14...122 °F) -40...85 °C (-40...185 °F)
Relative Humidity:	5 to 95% non-condensing
Atmosphere:	Important: The module must not be installed in an area where the ambient atmosphere contains volatile or corrosive gas, vapors or dust. If the module is not going to be installed for a period of time, it must be stored in an area where it will not be exposed to a corrosive atmosphere.

Specifications - Communication Options and Accessories

	20-750-BNETIP	20-750-CNETC	20-COMM-C	20-750-DNET	20-COMM-D	20-750-ENETR	20-COMM-E
Network Protocol: Data Rate:	BACnet/IP 10/100 Mbps	ControlNet 5 Mbps (fixed)	ControlNet 5 Mbps	DeviceNet 125, 250, and 500 Kbps	DeviceNet 125, 250, and 500 Kbps	EtherNet/IP 10/100 Mbps, Half/Full Duplex	EtherNet/IP 10/100 Mbps, Half/Full Duplex
Drive Protocol: Data Rates:	DPI 500 Kbps	DPI 500 Kbps	DPI 125 or 500 Kbps	DPI 500 Kbps	DPI 125 or 500 Kbps	DPI 500 Kbps	DPI 125 or 500 Kbps
Consumption Drive (DPI): Network:	250 mA at 14 VDC None	250 mA at 14V DC None	275 mA at 5V DC None	50 mA at 14V DC 60 mA at 24V DC	150 mA at 5 VDC 60 mA at 24 VDC	250 mA at 14 VDC None	370 mA at 5 VDC N/A
Dimensions: H x L x W	16.0 x 130.0 x 83.0 mm (0.63 x 5.12 x 3.27 in.)	68.0 x 150.0 x 26.0 mm (2.70 x 5.90 x 1.00 in.)	16.0 x 103.0 x 80.0 mm (0.63 x 4.00 x 3.13 in.)	68.0 x 150.0 x 26.0 mm (2.70 x 5.90 x 1.00 in.)	19.0 x 86.0 x 78.5 mm (0.75 x 3.39 x 3.09 in.)	68.0 x 150.0 x 26.0 mm (2.70 x 5.90 x 1.00 in.)	19.0 x 86.0 x 78.5 mm (0.75 x 3.39 x 3.09 in.)
Weight:	60 g (2.0 oz)	62 g (2.1 oz)	85 g (3.0 oz)	62 g (2.1 oz)	85 g (3.0 oz)	62 g (2.1 oz)	85 g (3.0 oz)
Compliance UL: c-UL: CE: C-Tick:	UL508C CAN/CSA C22.2 No. 14 EN61800-3 EN61800-3	UL508C CAN/CSA C22.2 No. 14 EN61800-3 EN61800-3	UL508C CAN/CSA C22.2 No. 14 EN61800-5-1, EN61800-3 EN61800-3	UL508C CAN/CSA C22.2 No. 14 EN61800-3 EN61800-3	UL508C CAN/CSA C22.2 No. 14 EN61800-5-1, EN61800-3 EN61800-3	UL508C CAN/CSA C22.2 No. 14 EN61800-3 EN61800-3	UL508C CAN/CSA C22.2 No. 14 EN61800-5-1, EN61800-3 EN61800-3

	20-COMM-H	20-COMM-K	20-COMM-L	20-COMM-M	20-750-PBUS	20-750-PNET/PNET2	20-COMM-P
Network Protocol: Data Rate:	Modbus RTU, Metasys N2 or Siemens P1 FLN RTU: 4800...38400 bps N2: 9600 bps P1: 4800 or 9600 bps	CANopen 10 Kbps...1 Mbps	LonWorks 78 Kbps	Modbus/TCP 10/100 Mbps, Half/Full Duplex	PROFIBUS 9600 bps...12 Mbps (autobauds)	Profinet 10/100 Mbps	PROFIBUS 10 Kbps...12 Mbps
Drive Protocol: Data Rates:	DPI 125 or 500 Kbps	DPI 125 or 500 Kbps	DPI 125 or 500 Kbps	DPI 125 or 500 Kbps	DPI 500 Kbps	DPI 500 Kbps	DPI 125 or 500 Kbps
Consumption Drive (DPI): Network:	150 mA at 5 VDC N/A	500 mA at 5V DC None	200 mA on DPI N/A	350 mA at 5V DC N/A	250 mA at 14V DC None	250 mA at 14 VDC None	370 mA at 5V DC N/A
Dimensions: H x L x W	19.0 x 86.0 x 78.5 mm (0.75 x 3.39 x 3.09 in.)	19.0 x 86.0 x 78.5 mm (0.75 x 3.39 x 3.09 in.)	20.0 x 86.0 x 78.5 mm (0.79 x 3.39 x 3.09 in.)	19.0 x 86.0 x 78.5 mm (0.75 x 3.39 x 3.09 in.)	16.0 x 130.0 x 83.0 mm (0.63 x 5.12 x 3.27 in.)	16.0 x 130.0 x 83.0 mm (0.63 x 5.12 x 3.27 in.)	19.0 x 86.0 x 78.5 mm (0.75 x 3.39 x 3.09 in.)
Weight:	85 g (3.0 oz)	85 g (3.0 oz)	85 g (3.0 oz)	85 g (3.0 oz)	57 g (2.0 oz)	60 g (2.0 oz)	57 g (2.0 oz)
Compliance UL: c-UL: CE: C-Tick:	UL508C CAN/CSA C22.2 No. 14 EN61800-5-1, EN61800-3 EN61800-3	UL508C CAN/CSA C22.2 No. 14 — —	UL508C — — —	UL508C CAN/CSA C22.2 No. 14 EN61800-5-1, EN61800-3 EN61800-3	UL508C CAN/CSA C22.2 No.14 IEC61800-3 EN61800-3	UL508C CAN/CSA C22.2 No. 14 EN61800-3 EN61800-3	UL508C CAN/CSA C22.2 No. 14 — —

	20-COMM-Q	20-COMM-R ⁽¹⁾	20-COMM-S	1203-SSS	1203-USB	1769-SM1
Network Protocol: Data Rate:	ControlNet 5 Mbps	Remote I/O 57.6, 115.2 or 230.4 Kbps	DF1 1200...38400 bps	DF1 9600...38400 bps	Universal Serial Bus (USB) 115.2 Kbps	—
Drive Protocol: Data Rates:	DPI 125 or 500 Kbps	DPI 125 or 500 Kbps	DPI 125 or 500 Kbps	DPI or SCANport 125 or 500 Kbps (DPI only)	SCANport, DPI or DSI 125, 125/500, 19.2 Kbps	DPI or SCANport 125 or 500 Kbps (DPI only)
Consumption Drive (DPI): Network:	275 mA at 5V DC N/A	250 mA at 5V DC N/A	150 mA at 5V DC N/A	130 mA at 12V DC N/A	130 mA at 12V DC 170 mA at +5V DC (DSI)	Module: 280 mA at 5V DC Channel: 60 mA at 12V DC
Dimensions: H x L x W	16.0 x 103.0 x 80.0 mm (0.63 x 4.00 x 3.13 in.)	19.0 x 86.0 x 78.5 mm (0.75 x 3.39 x 3.09 in.)	16.0 x 86.0 x 81.0 mm (0.63 x 3.34 x 3.16 in.)	103.5 x 73.4 x 23.6 mm (4.08 x 2.89 x 0.93 in.)	103.5 x 73.4 x 23.6 mm (4.08 x 2.89 x 0.93 in.)	103.5 x 73.4 x 23.6 mm (4.08 x 2.89 x 0.93 in.)
Weight:	85 g (3.0 oz)	85 g (3.0 oz)	60 g (2.0 oz)	71 g (2.5 oz)	71 g (2.5 oz)	71 g (2.5 oz)
Compliance UL: c-UL: CE: C-Tick:	UL508C CAN/CSA C22.2 No. 14 EN61800-5-1, EN61800-3 EN61800-3	UL508C CAN/CSA C22.2 No. 14 EN61800-3 EN61800-3	UL508C CAN/CSA C22.2 No. 14 EN61800-3 EN61800-3	UL508C CAN/CSA C22.2 No. 14 EN61800-5-1, EN61800-3 EN61800-3	UL508C CAN/CSA C22.2 No. 14 — —	UL508C CAN/CSA C22.2 No. 14 — —

(1) This item has [End of Life](#) status.

Specifications - Communication Options and Accessories (continued)

	20-XCOMM-DC-BASE	20-XCOMM-IO-OPT1	20-XCOMM-AC-PS1
Network Protocol:	Dependent on installed adapter	–	–
Data Rate:	Dependent on installed adapter	–	–
Drive Protocol:	DPI	–	–
Data Rates:	125/500 Kbps	–	–
Number of Inputs:	–	6 (single common)	–
Input Voltage Type:	–	24 VDC source load	–
Maximum Input Voltage:	–	27V DC	–
Rated Input Voltage:	–	–	100...240V AC
Operating Input Voltage:	–	–	90...264V AC
AC Input Frequency:	–	–	47...63 Hz
Maximum Input Current:	–	8 mA (each input)	–
Guaranteed ON-State Voltage:	–	10...27V DC (3 mA minimum)	–
Guaranteed OFF-State Voltage:	–	0...5V DC (2 mA maximum)	–
Reverse Polarity Protected:	–	-30V DC	–
Input Response Time:	–	25 ms + network update time ⁽²⁾	–
Number of Outputs:	–	2 relay outputs (individually isolated) 1 - Form C contacts 1 - Form A (NO) contact	–
Maximum Output Contact Voltage:	–	27V DC/125V AC	–
Maximum Output Contact Current:	–	2 A	–
Output Voltage:	–	–	24V DC
Output Current:	–	–	830 mA
Expected Contact Life:	–	1,000,000 cycles resistive at < 0.5 A 500,000 cycles inductive at < 0.5 A 500,000 cycles resistive at 1 A 300,000 cycles inductive at 1 A 300,000 cycles resistive at 2 A 150,000 cycles inductive at 2 A	–
Output Response Time:	–	25 ms + network update time ⁽³⁾	–
Consumption Module:	60 mA at 12V DC supplied from drive via DPI cable	–	–
Network:	Ethernet: None ControlNet: None DeviceNet: 60 mA at 24V DC	–	–
DC Power Supply Requirement	20-COMM-C: 105 mA at 24V DC ⁽¹⁾ 20-COMM-D: 60 mA at 24V DC ⁽¹⁾ 20-COMM-E: 140 mA at 24V DC ⁽¹⁾ 20-COMM-Q: 135 mA at 24V DC ⁽¹⁾ 20-COMM-M: 140 mA at 24V DC ⁽¹⁾	–	–
Dimensions (H x W x D):	108 x 108 x 75 mm (4.25 x 4.25 x 2.95 in.) with I/O terminal block attached	–	–
Weight:	340 g (12.0 oz)	–	–
Certifications	UL c-UL CE C-Tick	–	–
	UL508C CAN/CSA C22.2 No. 14 – –	–	–

(1) Since the Comms Kit is powered by a nominal 24 VDC, the current consumption listed in this table differs from the value shown on the label of the communication adapter, which is based on the adapter being powered by 5 VDC from the drive.

(2) The I/O board is NOT designed for fast I/O response times. Do NOT use with input devices that will transition (OFF-ON-OFF) faster than the response time. Potential input devices include auxiliary contact inputs from relays or overloads, pushbuttons, etc.

(3) The I/O board is NOT designed for fast I/O response times. Do NOT use with output devices that need to transition (OFF-ON-OFF) faster than the response time. Potential output devices include pilot lights or a contact closure reset to another hardware device.

Feedback Options

Description	Cat. No.
Incremental Encoder	20-750-ENC-1 ⁽¹⁾
Dual Incremental Encoder	20-750-DENC-1 ⁽¹⁾
Universal Feedback Board (includes Stegmann, Heidenhain, SSI, Biss, 5V Incremental)	20-750-UFB-1 ⁽²⁾

- (1) Homing and registration functions are not supported when using this device with Studio 5000 Logix Designer embedded motion instructions. To use these functions, the Universal Feedback Board (20-750-UFB-1) must be used.
- (2) PowerFlex 755 only.

This table specifies which encoder type combinations work on a single Universal Feedback Board (UFB).

		Encoder on Channel 0																				
		None	EnDat SC	Hiperface SC	BiSS SC	SSI SC	EnDat FD ChX	EnDat FD ChY	BiSS FD ChX	BiSS FD ChY	SSI FD ChX	SSI FD ChY	SinCos only	Incmtl A B Z	Incmtl SC	LinTempo ChX	LinTempo ChY	LinStahl ChX	LinStahl ChY	Lin SSI ChX	Lin SSI ChY	
Encoder on Channel 1	None	○	○	○	○	○	○	○	○	○	○	○	○	○	○	○	○	○	○	○	○	○
	EnDat SC	○	○	○	○	○	○	○	○	○	○	○	○	○	○	○	○	○	○	○	○	○
	Hiperface SC	○	○	○	○	○	○	○	○	○	○	○	○	○	○	○	○	○	○	○	○	○
	BiSS SC	○	○	○	○	○	○	○	○	○	○	○	○	○	○	○	○	○	○	○	○	○
	SSI SC	○	○	○	○	○	○	○	○	○	○	○	○	○	○	○	○	○	○	○	○	○
	EnDat FD ChX	○	○	○	○	○	●	●	●	○	●	○	○	○	○	○	○	○	○	○	○	○
	EnDat FD ChY	○	○	○	○	○	●	●	○	●	○	●	○	○	○	○	○	○	○	○	○	○
	BiSS FD ChX	○	○	○	○	○	●	○	●	●	○	○	○	○	○	○	○	○	○	○	○	○
	BiSS FD ChY	○	○	○	○	○	○	●	●	○	○	○	○	○	○	○	○	○	○	○	○	○
	SSI FD ChX	○	○	○	○	○	○	○	○	○	○	○	○	○	○	○	○	○	○	○	○	○
	SSI FD ChY	○	○	○	○	○	○	○	○	○	○	○	○	○	○	○	○	○	○	○	○	○
	SinCos only	○	○	○	○	○	○	○	○	○	○	○	○	○	○	○	○	○	○	○	○	○
	Incmtl A B Z	○	○	○	○	○	○	○	○	○	○	○	○	○	○	○	○	○	○	○	○	○
	Incmtl SC	○	○	○	○	○	○	○	○	○	○	○	○	○	○	○	○	○	○	○	○	○
	LinTempo ChX	○	○	○	○	○	○	○	○	○	○	○	○	○	○	○	○	○	○	○	○	○
	LinTempo ChY	○	○	○	○	○	○	○	○	○	○	○	○	○	○	○	○	○	○	○	○	○
	LinStahl ChX	○	○	○	○	○	○	○	○	○	○	○	○	○	○	○	○	○	○	○	○	○
LinStahl ChY	○	○	○	○	○	○	○	○	○	○	○	○	○	○	○	○	○	○	○	○	○	
Lin SSI ChX	○	○	○	○	○	○	○	○	○	○	○	○	○	○	○	○	○	○	○	○	○	
Lin SSI ChY	○	○	○	○	○	○	○	○	○	○	○	○	○	○	○	○	○	○	○	○	○	

- Compatible
- Non-compatible

I/O Option Kits

Description ⁽¹⁾	Cat. No.
ATEX Option Module with 1 Thermosensor Input Connection (requires 11-Series I/O Module below)	20-750-ATEX
24V DC 11-Series I/O Module with 1 Analog In, 1 Analog Out, 3 Digital In and 2 Relay Outputs	20-750-1132C-2R
24V DC 11-Series I/O Module with 1 Analog In, 1 Analog Out, 3 Digital In, 1 Relay and 2 Transistor Outputs	20-750-1133C-1R2T
115V AC 11-Series I/O Module with 1 Analog In, 1 Analog Out, 3 Digital In and 2 Relay Outputs	20-750-1132D-2R
24V DC 22-Series I/O Module with 2 Analog In, 2 Analog Out, 6 Digital In and 2 Relay Outputs	20-750-2262C-2R
115V AC 22-Series I/O Module with 2 Analog In, 2 Analog Out, 6 Digital In and 2 Relay Outputs	20-750-2262D-2R
24V DC 22-Series I/O Module with 2 Analog In, 2 Analog Out, 6 Digital In, 3 Digital Out, 1 Relay and 2 Transistor Outputs	20-750-2263C-1R2T

(1) I/O option kits are not allowed in CIP motion mode.

Safety Options

Two safety options are available for the PowerFlex 750-Series:

- Safe Torque Off
- Safe Speed Monitor

Safe Torque Off is ideal for safety related applications requiring removal of rotational power to the motor without shutting down the drive. Safe Torque Off functionality offers the benefit of quick start-up after a demand on the safety system and helps reduce wear from repetitive start-up and provides safety ratings up to and including SIL CL3, PLe, and Category 3.

In applications where the speed needs to be controlled and monitored, the Safe-Speed Monitor option combines Safe Torque Off capability with integrated safety relay functionality and the Safe-Speed Control technology in one hardware option to provide safety ratings up to and including SIL CL3, PLe, and Category 4.

With the Safe Speed Monitor option you can safely monitor and control the speed of your application which allows operators to perform process or maintenance work without stopping the machine.

Description	Cat. No.
Safe Torque Off	20-750-S ⁽¹⁾
Safe Speed Monitor	20-750-S1 ^{(1) (2)}

(1) Drive can accommodate only one option.

(2) Requires the Dual Incremental Encoder or Universal Feedback Option. Also requires the 20-750-EMCSSM1-F8 EMC Option Kit with Frame 8...9 drives.

Specifications - Safety Options

	Safe-Torque Off	Safe Speed Monitor
Standards:	IEC/EN60204-1, ISO13489-1, IEC 61508, IEC 61800-5-2	IEC/EN60204-1, ISO12100, IEC 61508, IEC 61800-5-2
Safety Category:	Cat. 3 and PL(e) per EN ISO 13849-1; SIL CL3 per IEC 61508 and EN 62061	Cat. 4 and PL(e) per EN ISO 13849-1; SIL CL3 per IEC 61508 and EN 62061
Power Supply (user I/O):	24V DC $\pm 10\%$, 0.8...1.1 x rated voltage ⁽³⁾ PELV or SELV	
Power Consumption:	4.4 W	36 W
Safety Enable (SE+, SE-):	24V DC, 22 mA, short-circuit protected	–
Safety Power (SP+, SP-):	24V DC, 35 mA, short-circuit protected	–
SLS Outputs (68, 78):	–	24V DC, 50mA, short-circuit protected
SS Outputs (34, 44):	–	24V DC, 50 mA, short-circuit protected
Door Control Outputs (51, 52):	–	24V DC, short-circuit protected, 0.75 A bipolar (Power to Release/Power to Lock) configuration. 20 mA, cascading (2Ch Source) configuration.
Pulse Outputs (S11, S21):	–	24V DC, 50 mA, short-circuit protected
Pulse Inputs (S12, S22, S32, S42, S52, S62, S72, S82, X32, X42):	–	5 mA per input, max
Input ON Voltage, Minimum:	24V DC $\pm 10\%$, 21.6...26.4V DC	15V
Input OFF Voltage, Maximum:	5V	5V
Input OFF Current, Maximum:	2.5 mA @ 5V DC	2 mA
Input-to-Output Response Time (SS_In, SLS_In, DM_In, ESM_In, LM_In):	–	20 ms
Overspeed Response Time:	–	User-configurable
Inputs (S34):	–	5 mA per input, max
Conductor Size ⁽¹⁾ :	0.3...0.8 mm ² (28...18 AWG)	0.25...2.5 mm ² (24...14 AWG)
Strip Length:	10 mm (0.39 in.)	6 mm (0.25 in.)
Terminal Screw Torque	–	0.2...0.25 N•m (1.8...2.2 lb•in)
Certification ⁽²⁾		
c-UL-us	UL Listed, certified for US and Canada.	
CE	European Union 2004/108/EC EMC Directive, and EU 2006/42/EC Machinery Directive EN 61800-3; categories C2 and C3 EN 62061; EM Immunity EN ISO 13849-1 EN 61800-5-1 EN 61800-5-2 EN 61508 Parts 1-7	
C-Tick	Australian Radiocommunications Act, compliant with: EN 61800-3; categories C2 and C3	
TÜV	TÜV Certified for Functional Safety: up to SIL CL3, according to EN 61800-5-2, EN 61508, and EN 62061; up to Performance Level PL(e) and Category 3, according to EN ISO 13849-1; when used as described.	TÜV Certified for Functional Safety: up to SIL CL3, according to EN 61800-5-2, EN 61508, and EN 62061; up to Performance Level PL(e) and Category 4, according to EN ISO 13849-1; when used as described.

(1) Refer to Industrial Automation Wiring and Grounding Guidelines, publication 1770-4.1.

(2) When product is marked.

(3) Safety outputs need additional fuse for reverse voltage protection of the control circuit. Install a 6 A slow-blow or 10 A fast-acting fuse.

PowerFlex 750-Series Option Kits

Description	Frame(s)	Cat. No.
Auxiliary Power Supply	24V Aux Power Supply	1...7 ⁽³⁾ 20-750-APS
DC Bus Bar Option Kit	DC Bus Bars for 380...480V AC Drives	6 20-750-DCBB1-F6
		7 20-750-DCBB1-F7
	DC Bus Bars for 600...690V AC Drives	6 20-750-DCBB2-F6
		7 20-750-DCBB2-F7
DC Bus Connection Kit	Allows connection of the drive DC bus terminals to the bus rails at the back of the cabinet. ⁽¹⁾	8 20-750-BUS1A-F8
EMC Option Kit	EMC Plate with Core for 380...480V AC drives	1 20-750-EMC1-F1
		2 20-750-EMC1-F2
		3 20-750-EMC1-F3
	EMC Plate with Core for 600V AC drives	3 20-750-EMC3-F3
	EMC Plate with Cores for 380...480V AC drives	4 20-750-EMC1-F4
		5 20-750-EMC1-F5
	EMC Plate with Cores for 600V AC drives	4 20-750-EMC3-F4
		5 20-750-EMC3-F5
	EMC Core for 380...480V AC drives	1 20-750-EMC2-F1
		2 20-750-EMC2-F2
		3 20-750-EMC2-F3
	EMC Core for 600V AC drives	3 20-750-EMC4-F3
	EMC Cores for 380...480V AC drives	4...5 20-750-EMC2-F45
	EMC Cores for 600V AC drives	4 20-750-EMC4-F4
		5 20-750-EMC4-F5
	EMC Plate with Cores for 600...690V AC drives	6 20-750-EMC3-F6
		7 20-750-EMC3-F7
EMC Plate with Cores for 600...690V AC drives (IP54 Only)	6 20-750-EMC5-F6	
	7 20-750-EMC5-F7	
EMC Core – Inverter-mounted output, for 380...690V AC Input and DC Input drives. ⁽²⁾	8...10 20-750-EMCCM1-F8	
EMC Cores – Required when using the Safe Speed Monitor option 20-750-S1 with 380...690V drives.	8...10 20-750-EMCSSM1-F8	
Exhaust Hood	Exhaust Hood – IP20, NEMA/UL Type 1 drives	8 20-750-HOOD1-F8
Flange Adapter Kit	Converts Open Type drive to external heatsink (flange) with NEMA/UL Type 1 integrity backside. This kit is for use with IP20, NEMA/UL Type 0 drives and will not provide an air-tight or water-tight seal. Where sealing is required (e.g. contaminated, dirty or wet environments), a drive with an "F" enclosure option must be used.	2 20-750-FLNG1-F2
		3 20-750-FLNG1-F3
		4 20-750-FLNG1-F4
		5 20-750-FLNG1-F5
	Converts Open Type drive to external heatsink (flange) with NEMA/UL Type 4X/12 integrity backside.	6 20-750-FLNG4-F6
		7 20-750-FLNG4-F7
L Bus Bar Kit	Includes three L-brackets	8...10 20-750-LBRKT1

continued

Description		Frame(s)	Cat. No.
NEMA/UL Type 1 Option Kit	NEMA/UL Type 1 Kit	1	20-750-NEMA1-F1
		2	20-750-NEMA1-F2
		3	20-750-NEMA1-F3
		4	20-750-NEMA1-F4
		5	20-750-NEMA1-F5
		6	20-750-NEMA1-F6
		7	20-750-NEMA1-F7
Power Terminal Extension	Allows connection of two parallel leads to the AC power terminals.	6	20-750-ACTE1-F6
Power Terminal Guard	Provides additional protection against contact with the power terminals.	6	20-750-PTG1-F6
		7	20-750-PTG1-F7
Remote Control POD Mounting Kit	Fiber-optic and power supply cables needed to remotely mount the control POD up to 23 m (75 ft) from the drive.	8...10	20-750-RPD1-F8
Roll-out Cart	A wheeled roll-out cart that facilitates drive installation and removal. Required for Frame 8 and larger drives.	8...10	20-750-CART1-F8

(1) DC bus access is included with Frames 9 and 10.

(2) Frame 8 requires one EMC output core, Frame 9 requires two EMC output cores, and Frame 10 requires three EMC output cores.

(3) Frame 8 and up drives can be powered from an external 24V DC source, a 20-750-APS is not required.

PowerFlex 755 IP00, NEMA/UL Open Type Drive Options

Description	Required?	Frame 8		Frame 9		Frame 10	
		Cat. No.	Qty.	Cat. No.	Qty.	Cat. No.	Qty.
Field Termination, Converter, AC Input	Recommended	20-750-BUS2-F8	1	20-750-BUS2-F9	1	20-750-BUS2-F10	1
Field Termination, Inverter, AC Output	Recommended	20-750-BUS3-F8	1	20-750-BUS3-F9	1	20-750-BUS3-F10	1
Field Termination, DC Bus, 400/480V	Recommended	20-750-BUS4-F8	1	20-750-BUS4-F9	1	20-750-BUS4-F10	1
Field Termination, DC Bus, 600/690V	Recommended	20-750-BUS4-F8	1	20-750-BUS6-F9	1	20-750-BUS6-F10	1
Field Termination, DC Input, Common Bus Precharge ⁽¹⁾⁽²⁾	Recommended	20-750-BUS5-F8	1	20-750-BUS5-F9	1	20-750-BUS5-F10	1
Pod Bucket Assembly	Required	20-750-POD1-F8	1	20-750-POD1-F8	1	20-750-POD1-F8	1
Pod, Cable, 24 Volt Supply ⁽³⁾	Required	20-750-PH1-F8	⁽⁴⁾	20-750-PH2-F9	1	20-750-PH3-F10	1
Cable, Fiber Optic, 560 mm (22 in) ⁽³⁾	Required	20-750-FCBL1-F8	1	–	–	–	–
Cable, Fiber Optic, 2.8 m (110 in) ⁽³⁾	Required	–	–	20-750-FCBL1-F10	2	20-750-FCBL1-F10	3
Transceiver, Fiber Optic	Required	–	–	SK-R1-FTR1-F8	1	SK-R1-FTR1-F8	2
Pod, Remote Mounting Kit	Optional	20-750-RPD1-F8	1	–	–	–	–
Mounting Kit, Back Panel	Recommended	20-750-MNT2-F8	1	20-750-MNT2-F9	1	20-750-MNT2-F10	1
Mounting Kit, Floor	Recommended	20-750-MNT3-F8	1	20-750-MNT3-F9	1	20-750-MNT3-F10	1
Duct, Top Outlet	Recommended	20-750-DUCT2-F8	1	20-750-DUCT2-F8	2	20-750-DUCT2-F8	3
Duct, Bottom Inlet	Recommended	20-750-DUCT4-F8	1	20-750-DUCT4-F8	2	20-750-DUCT4-F8	3
Roll-Out Cart	Recommended	20-750-CART1-F8	1	20-750-CART1-F8	1	20-750-CART1-F8	1
Control Power Circuit Breaker ⁽²⁾	Recommended	1489-A2D130	1	1489-A2D130	2	1489-A2D130	3
Control Power Circuit Breaker Lock ⁽²⁾	Recommended	1489-AALOA	1	1489-AALOA	2	1489-AALOA	3
EMC Core, Converter Input, AC Input	Optional	20-750-EMCBUS1-F8	1	20-750-EMCBUS1-F8	2	20-750-EMCBUS1-F8	3
EMC Core, Inverter Output	Optional	20-750-EMCCM1-F8	1	20-750-EMCCM1-F8	2	20-750-EMCCM1-F8	3

- (1) EMC cores are included with the 20-750-BUS5-Fx kits.
- (2) Common DC input drives only.
- (3) 20-750-PH1-Fx and 20-750-FBCL1-Fx kits are used if the Control Pod is mounted in the drive. If the Control Pod is to be remote mounted (up to 23 m or 75 ft away), order a 20-750-RPD1-Fx kit instead.
- (4) 24 volt supply cable is included with each Frame 8 drive unit.

Internal Dynamic Brake Resistor Kits

These resistors have a limited duty cycle. To determine whether an internal resistor is sufficient for your application, see the PowerFlex Dynamic Braking Resistor Calculator Application Technique, publication [PFLEX-AT001](#). An external resistor may be required.

Drive Input Voltage	Frame	Rating (ND kW)	Rating (ND Hp)	Brake Resistance (Ohms)	Cat. No.
380...480V AC	1	0.75...2.2	1...3	115	20-750-DB1-D1A
		4...7.5	5...10	62	20-750-DB1-D1
	2	0.75...11	1...15	62	20-750-DB1-D2

Terminators

Description ⁽¹⁾	Cat. No.
for use with 3.7 kW (5 Hp) & below drives	1204-TFA1
for use with 1.5 kW (2 Hp) & up drives	1204-TFB2

(1) See Appendix A of the Wiring and Grounding Guidelines for Pulse Width Modulated (PWM) AC Drives, publication [Drives-IN001](#) for selection information.

Reflected Wave Reduction Modules w/Common Mode Choke

Description ⁽¹⁾	Cat. No.
17A with Common Mode Choke	1204-RWC-17-A

(1) See Appendix A of the Wiring and Grounding Guidelines for Pulse Width Modulated (PWM) AC Drives, publication [Drives-IN001](#) for selection information.

Reflected Wave Reduction Modules

ND kW	ND Hp	Catalog Number	
		380...480V AC	600V AC
4	5	1321-RWR8-DP	1321-RWR8-EP
5.5	7.5	1321-RWR12-DP	1321-RWR12-EP
7.5	10	1321-RWR18-DP	1321-RWR18-EP
11	15	1321-RWR25-DP	1321-RWR25-EP
15	20	1321-RWR35-DP	1321-RWR35-EP
18.5	25	1321-RWR35-DP	1321-RWR35-EP
22	30	1321-RWR45-DP	1321-RWR45-EP
30	40	1321-RWR55-DP	1321-RWR55-EP
37	50	1321-RWR80-DP	1321-RWR80-EP
45	60	1321-RWR80-DP	1321-RWR80-EP
55	75	1321-RWR100-DP	1321-RWR100-EP
75	100	1321-RWR130-DP	1321-RWR130-EP
90	125	1321-RWR160-DP	1321-RWR160-EP
110	150	1321-RWR200-DP	1321-RWR200-EP
149	200	1321-RWR250-DP	1321-RWR250-EP
187	250	1321-RWR320-DP	1321-RWR320-EP

Isolation Transformers

IP32, NEMA/UL Type 3R Standalone, 4...6% Nominal Impedance

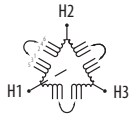

Diagram 1

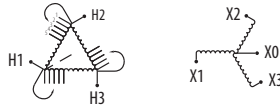

Diagram 2

460V, 60 Hz, Three-Phase, 460V Primary & 460V Secondary

Motor Rating		Wiring Diagram	Cat. No.
kW	Hp		
0.75	1	1	1321-3TW005-BB
1.5	2	1	1321-3TW005-BB
2.2	3	1	1321-3TW005-BB
22	30	2	1321-3TW040-BB
30	40	2	1321-3TW051-BB
37	50	2	1321-3TH063-BB
45	60	2	1321-3TH075-BB
55	75	2	1321-3TH093-BB
75	100	2	1321-3TH118-BB
90	125	2	1321-3TH145-BB

Motor Rating		Wiring Diagram	Cat. No.
kW	Hp		
110	150	2	1321-3TH175-BB
149	200	2	1321-3TH220-BB
187	250	2	1321-3TH275-BB
224	300	2	1321-3TH330-BB
261	350	1	1321-3TH440-BB
298	400	1	1321-3TH440-BB
336	450	1	1321-3TH550-BB
373	500	1	1321-3TH550-BB
448	600	1	1321-3TH660-BB
485	650	1	—

Motor Rating		Wiring Diagram	Cat. No.
kW	Hp		
522	700	1	1321-3TH770-BB
560	750	1	1321-3TH770-BB
597	800	1	1321-3TH880-BB
671	900	900 kVA	A 1321 Isolation Transformer solution is not available. Approximate drive kVA is shown at left.
746	1000	1000 kVA	
821	1100	1200 kVA	
933	1250	1200 kVA	
1007	1350	1300 kVA	
1119	1500	1500 kVA	
1492	2000	2000 kVA	

575V, 60 Hz, Three-Phase, 575V Primary & 575V Secondary

Motor Rating		Wiring Diagram	Cat. No.
kW	Hp		
0.75	1	1	1321-3TW005-CC
1.5	2	1	1321-3TW005-CC
2.2	3	1	1321-3TW005-CC
22	30	2	1321-3TW040-CC
30	40	2	1321-3TW051-CC
37	50	2	1321-3TH063-CC
45	60	2	1321-3TH075-CC
55	75	2	1321-3TH093-CC
75	100	1	1321-3TH118-CC

Motor Rating		Wiring Diagram	Cat. No.
kW	Hp		
90	125	1	1321-3TH145-CC
110	150	1	1321-3TH175-CC
149	200	1	1321-3TH220-CC
187	250	1	1321-3TH275-CC
224	300	1	1321-3TH330-CC
261	350	1	1321-3TH440-CC
298	400	1	1321-3TH550-CC
336	450	1	1321-3TH550-CC
373	500	1	1321-3TH660-CC

Motor Rating		Wiring Diagram	Cat. No.
kW	Hp		
410	550	1	1321-3TH660-CC
448	600	1	1321-3TH770-CC
522	700	1	1321-3TH770-CC
597	800	1	1321-3TH880-CC
671	900	950 kVA	A 1321 Isolation Transformer solution is not available. Approximate drive kVA is shown at left.
709	950	1000 kVA	
746	1000	1100 kVA	
895	1200	1200 kVA	
1119	1500	1500 kVA	

Input and Output Reactors

380...480V, 50/60 Hz, Three-Phase, 3% Impedance

kW	Hp	Duty	Input Line Reactor		Output Load Reactor	
			IP00 (Open Style)	IP11 (NEMA/UL Type 1)	IP00 (Open Style)	IP11 (NEMA/UL Type 1)
			Cat. No.	Cat. No.	Cat. No.	Cat. No.
0.75	1	Normal	1321-3R2-A	1321-3RA2-A	1321-3R2-A	1321-3RA2-A
1.1	1.5	Heavy	1321-3R4-C	1321-3RA4-C	1321-3R4-B	1321-3RA4-B
1.5	2	Normal	1321-3R4-B	1321-3RA4-B	1321-3R4-B	1321-3RA4-B
		Heavy	1321-3R4-B	1321-3RA4-B	1321-3R8-C	1321-3RA8-C
2.2	3	Normal	1321-3R8-C	1321-3RA8-C	1321-3R8-C	1321-3RA8-C
		Heavy	1321-3R8-C	1321-3RA8-C	1321-3R8-B	1321-3RA8-B
4	5	Normal	1321-3R8-B	1321-3RA8-B	1321-3R8-B	1321-3RA8-B
		Heavy	1321-3R8-B	1321-3RA8-B	1321-3R12-B	1321-3RA12-B
5.5	7.5	Normal	1321-3R12-B	1321-3RA12-B	1321-3R12-B	1321-3RA12-B
		Heavy	1321-3R12-B	1321-3RA12-B	1321-3R18-B	1321-3RA18-B
7.5	10	Normal	1321-3R18-B	1321-3RA18-B	1321-3R18-B	1321-3RA18-B
		Heavy	1321-3R18-B	1321-3RA18-B	1321-3R25-B	1321-3RA25-B
11	15	Normal	1321-3R25-B	1321-3RA25-B	1321-3R25-B	1321-3RA25-B
		Heavy	1321-3R25-B	1321-3RA25-B	1321-3R25-B	1321-3RA25-B
15	20	Normal	1321-3R35-B	1321-3RA35-B	1321-3R25-B	1321-3RA25-B
		Heavy	1321-3R35-B	1321-3RA35-B	1321-3R35-B	1321-3RA35-B
18.5	25	Normal	1321-3R35-B	1321-3RA35-B	1321-3R35-B	1321-3RA35-B
		Heavy	1321-3R35-B	1321-3RA35-B	1321-3R45-B	1321-3RA45-B
22	30	Normal	1321-3R45-B	1321-3RA45-B	1321-3R45-B	1321-3RA45-B
		Heavy	1321-3R45-B	1321-3RA45-B	1321-3R55-B	1321-3RA55-B
30	40	Normal	1321-3R55-B	1321-3RA55-B	1321-3R55-B	1321-3RA55-B
		Heavy	1321-3R55-B	1321-3RA55-B	1321-3R80-B	1321-3RA80-B
37	50	Normal	1321-3R80-B	1321-3RA80-B	1321-3R80-B	1321-3RA80-B
		Heavy	1321-3R80-B	1321-3RA80-B	1321-3R80-B	1321-3RA80-B
45	60	Normal	1321-3R80-B	1321-3RA80-B	1321-3R80-B	1321-3RA80-B
		Heavy	1321-3R80-B	1321-3RA80-B	1321-3R80-B	1321-3RA80-B
55	75	Normal	1321-3R100-B	1321-3RA100-B	1321-3R100-B	1321-3RA100-B
		Heavy	1321-3R100-B	1321-3RA100-B	1321-3R100-B	1321-3RA100-B
75	100	Normal	1321-3R130-B	1321-3RA130-B	1321-3R130-B	1321-3RA130-B
		Heavy	1321-3R130-B	1321-3RA130-B	1321-3R130-B	1321-3RA130-B
90	125	Normal	1321-3R160-B	1321-3RA160-B	1321-3R160-B	1321-3RA160-B
		Heavy	1321-3R160-B	1321-3RA160-B	1321-3R160-B	1321-3RA160-B
110	150	Normal	1321-3R200-B	1321-3RA200-B	1321-3R200-C	1321-3RA200-C
		Heavy	1321-3R200-B	1321-3RA200-B	1321-3R200-C	1321-3RA200-C
–	200	Normal/Heavy	1321-3RB250-B	1321-3RAB250-B	1321-3RB250-B	1321-3RAB250-B
132	–	Normal/Heavy	1321-3RB320-B	1321-3RAB320-B	1321-3RB320-B	1321-3RAB320-B
160	250	Normal/Heavy	1321-3RB320-B	1321-3RAB320-B	1321-3RB320-B	1321-3RAB320-B
–	300	Normal/Heavy	1321-3RB400-B	1321-3RAB400-B	1321-3RB400-B	1321-3RAB400-B
200	–	Normal/Heavy	1321-3RB400-B	1321-3RAB400-B	1321-3RB400-B	1321-3RAB400-B
–	350	Normal/Heavy	1321-3R500-B	1321-3RA500-B	1321-3R500-B	1321-3RA500-B
250	–	Normal/Heavy	1321-3R500-B	1321-3RA500-B	1321-3R500-B	1321-3RA500-B
270	–	Normal/Heavy	1321-3R500-B	1321-3RA500-B	1321-3R500-B	1321-3RA500-B
–	400	Light/Normal/Heavy	1321-3R500-B	1321-3RA500-B	1321-3R500-B	1321-3RA500-B
315	–	Light/Normal/Heavy	1321-3R600-B	1321-3RA600-B	1321-3R600-B	1321-3RA600-B

kW	Hp	Duty	Input Line Reactor		Output Load Reactor	
			IP00 (Open Style)	IP11 (NEMA/UL Type 1)	IP00 (Open Style)	IP11 (NEMA/UL Type 1)
			Cat. No.	Cat. No.	Cat. No.	Cat. No.
–	450	Light/Normal/Heavy	1321-3R600-B	1321-3RA600-B	1321-3R600-B	1321-3RA600-B
355	–	Light/Normal/Heavy	1321-3R750-B	1321-3RA750-B	1321-3R750-B	1321-3RA750-B
–	500	Light	1321-3R600-B	1321-3RA600-B	1321-3R600-B	1321-3RA600-B
		Normal/Heavy	1321-3R750-B	1321-3RA750-B	1321-3R750-B	1321-3RA750-B
400	–	Light/Heavy	1321-3R750-B	1321-3RA750-B	1321-3R750-B	1321-3RA750-B
		Normal	1321-3R850-B	1321-3RA850-B	1321-3R850-B	1321-3RA850-B
–	600	Light/Normal/Heavy	1321-3R750-B	1321-3RA750-B	1321-3R750-B	1321-3RA750-B
450	–	Light	1321-3R850-B	1321-3RA850-B	1321-3R850-B	1321-3RA850-B
–	650	Light	1321-3R850-B	1321-3RA850-B	1321-3R850-B	1321-3RA850-B
		Normal	1321-3R750-B	1321-3RA750-B	1321-3R750-B	1321-3RA750-B
–	700	Light/Normal/Heavy	1321-3R850-B	1321-3RA850-B	1321-3R850-B	1321-3RA850-B
–	750	Heavy	1321-3R850-B	1321-3RA850-B	1321-3R850-B	1321-3RA850-B
500	–	Normal/Heavy	1321-3R1000-B	1321-3RA1000-B	1321-3R1000-B	1321-3RA1000-B
–	800	Light/Normal/Heavy	1321-3R1000-B	1321-3RA1000-B	1321-3R1000-B	1321-3RA1000-B
560	–	Light/Normal/Heavy	1321-3R600-B ⁽¹⁾	1321-3RA600-B ⁽¹⁾	1321-3R600-B ⁽¹⁾	1321-3RA600-B ⁽¹⁾
–	900	Light/Normal/Heavy	1321-3R600-B ⁽¹⁾	1321-3RA600-B ⁽¹⁾	1321-3R600-B ⁽¹⁾	1321-3RA600-B ⁽¹⁾
		Light/Normal/Heavy	1321-3R600-B ⁽¹⁾	1321-3RA600-B ⁽¹⁾	1321-3R600-B ⁽¹⁾	1321-3RA600-B ⁽¹⁾
630	–	Light/Normal/Heavy	1321-3R600-B ⁽¹⁾	1321-3RA600-B ⁽¹⁾	1321-3R600-B ⁽¹⁾	1321-3RA600-B ⁽¹⁾
–	1000	Light/Normal/Heavy	1321-3R600-B ⁽¹⁾	1321-3RA600-B ⁽¹⁾	1321-3R600-B ⁽¹⁾	1321-3RA600-B ⁽¹⁾
		Light/Normal/Heavy	1321-3R600-B ⁽¹⁾	1321-3RA600-B ⁽¹⁾	1321-3R600-B ⁽¹⁾	1321-3RA600-B ⁽¹⁾
710	–	Light/Normal/Heavy	1321-3R600-B ⁽¹⁾	1321-3RA600-B ⁽¹⁾	1321-3R600-B ⁽¹⁾	1321-3RA600-B ⁽¹⁾
–	1100	Light/Normal	1321-3R750-B ⁽¹⁾	1321-3RA750-B ⁽¹⁾	1321-3R750-B ⁽¹⁾	1321-3RA750-B ⁽¹⁾
		Light/Normal	1321-3R750-B ⁽¹⁾	1321-3RA750-B ⁽¹⁾	1321-3R750-B ⁽¹⁾	1321-3RA750-B ⁽¹⁾
800	–	Light/Normal	1321-3R750-B ⁽¹⁾	1321-3RA750-B ⁽¹⁾	1321-3R750-B ⁽¹⁾	1321-3RA750-B ⁽¹⁾
–	1250	Light/Normal	1321-3R750-B ⁽¹⁾	1321-3RA750-B ⁽¹⁾	1321-3R750-B ⁽¹⁾	1321-3RA750-B ⁽¹⁾
		Light/Normal	1321-3R750-B ⁽¹⁾	1321-3RA750-B ⁽¹⁾	1321-3R750-B ⁽¹⁾	1321-3RA750-B ⁽¹⁾
850	–	Light/Normal	1321-3R750-B ⁽¹⁾	1321-3RA750-B ⁽¹⁾	1321-3R750-B ⁽¹⁾	1321-3RA750-B ⁽¹⁾
–	1350	Light	1321-3R850-B ⁽¹⁾	1321-3RA850-B ⁽¹⁾	1321-3R850-B ⁽¹⁾	1321-3RA850-B ⁽¹⁾
		Light	1321-3R850-B ⁽¹⁾	1321-3RA850-B ⁽¹⁾	1321-3R850-B ⁽¹⁾	1321-3RA850-B ⁽¹⁾
900	–	Light	1321-3R850-B ⁽¹⁾	1321-3RA850-B ⁽¹⁾	1321-3R850-B ⁽¹⁾	1321-3RA850-B ⁽¹⁾
–	1500	Light	1321-3R850-B ⁽²⁾	1321-3RA850-B ⁽²⁾	1321-3R850-B ⁽²⁾	1321-3RA850-B ⁽²⁾
		Light	1321-3R850-B ⁽²⁾	1321-3RA850-B ⁽²⁾	1321-3R850-B ⁽²⁾	1321-3RA850-B ⁽²⁾
1000	–	Light	1321-3R850-B ⁽²⁾	1321-3RA850-B ⁽²⁾	1321-3R850-B ⁽²⁾	1321-3RA850-B ⁽²⁾
–	2000	Light	1321-3R850-B ⁽²⁾	1321-3RA850-B ⁽²⁾	1321-3R850-B ⁽²⁾	1321-3RA850-B ⁽²⁾
		Light	1321-3R850-B ⁽²⁾	1321-3RA850-B ⁽²⁾	1321-3R850-B ⁽²⁾	1321-3RA850-B ⁽²⁾
1400	–	Light	1321-3R850-B ⁽²⁾	1321-3RA850-B ⁽²⁾	1321-3R850-B ⁽²⁾	1321-3RA850-B ⁽²⁾

- (1) Requires two reactors wired in parallel.
- (2) Requires three reactors wired in parallel.

380...480V, 50/60 Hz, Three-Phase, 5% Impedance

kW	Hp	Duty	Input Line Reactor		Output Load Reactor	
			IP00 (Open Style)	IP11 (NEMA/UL Type 1)	IP00 (Open Style)	IP11 (NEMA/UL Type 1)
			Cat. No.	Cat. No.	Cat. No.	Cat. No.
0.75	1	Normal	1321-3R2-B	1321-3RA2-B	1321-3R2-B	1321-3RA2-B
1.1	1.5	Heavy	1321-3R4-D	1321-3RA4-D	1321-3R4-D	1321-3RA4-D
1.5	2	Normal	1321-3R4-D	1321-3RA4-D	1321-3R4-D	1321-3RA4-D
		Heavy	1321-3R4-D	1321-3RA4-D	1321-3R8-D	1321-3RA8-D
2.2	3	Normal	1321-3R8-D	1321-3RA8-D	1321-3R8-D	1321-3RA8-D
		Heavy	1321-3R8-D	1321-3RA8-D	1321-3R8-C	1321-3RA8-C
4	5	Normal	1321-3R8-C	1321-3RA8-C	1321-3R8-C	1321-3RA8-C
		Heavy	1321-3R8-C	1321-3RA8-C	1321-3R12-C	1321-3RA12-C
5.5	7.5	Normal	1321-3R12-C	1321-3RA12-C	1321-3R12-C	1321-3RA12-C
		Heavy	1321-3R12-C	1321-3RA12-C	1321-3R18-C	1321-3RA18-C
7.5	10	Normal	1321-3R18-C	1321-3RA18-C	1321-3R18-C	1321-3RA18-C
		Heavy	1321-3R18-C	1321-3RA18-C	1321-3R25-C	1321-3RA25-C
11	15	Normal/Heavy	1321-3R25-C	1321-3RA25-C	1321-3R25-C	1321-3RA25-C
15	20	Normal	1321-3R35-C	1321-3RA35-C	1321-3R25-C	1321-3RA25-C
		Heavy	1321-3R35-C	1321-3RA35-C	1321-3R35-C	1321-3RA35-C
18.5	25	Normal	1321-3R35-C	1321-3RA35-C	1321-3R35-C	1321-3RA35-C
		Heavy	1321-3R35-C	1321-3RA35-C	1321-3R45-C	1321-3RA45-C
22	30	Normal	1321-3R45-C	1321-3RA45-C	1321-3R45-C	1321-3RA45-C
		Heavy	1321-3R45-C	1321-3RA45-C	1321-3R55-C	1321-3RA55-C
30	40	Normal	1321-3R55-C	1321-3RA55-C	1321-3R55-C	1321-3RA55-C
		Heavy	1321-3R55-C	1321-3RA55-C	1321-3R80-C	1321-3RA80-C
37	50	Normal	1321-3R80-C	1321-3RA80-C	1321-3R80-C	1321-3RA80-C
		Heavy	1321-3R80-C	1321-3RA80-C	1321-3R80-C	1321-3RA80-C
45	60	Normal/Heavy	1321-3R80-C	1321-3RA80-C	1321-3R80-C	1321-3RA80-C
55	75	Normal/Heavy	1321-3R100-C	1321-3RA100-C	1321-3R100-C	1321-3RA100-C
75	100	Normal/Heavy	1321-3R130-C	1321-3RA130-C	1321-3R130-C	1321-3RA130-C
90	125	Normal/Heavy	1321-3R160-C	1321-3RA160-C	1321-3R160-C	1321-3RA160-C
110	150	Normal	1321-3R200-C	1321-3RA200-C	1321-3R200-C	1321-3RA200-C
		Heavy	1321-3R200-C	1321-3RA200-C	1321-3R200-C	1321-3RA200-C
–	200	Normal/Heavy	1321-3RB250-C	1321-3RAB250-C	1321-3RB250-C	1321-3RAB250-C
132	–	Normal/Heavy	1321-3RB320-C	1321-3RAB320-C	1321-3RB320-C	1321-3RAB320-C
160	250	Normal/Heavy	1321-3RB320-C	1321-3RAB320-C	1321-3RB320-C	1321-3RAB320-C
–	300	Normal/Heavy	1321-3RB400-C	1321-3RAB400-C	1321-3RB400-C	1321-3RAB400-C
200	–	Normal/Heavy	1321-3RB400-C	1321-3RAB400-C	1321-3RB400-C	1321-3RAB400-C
–	350	Normal/Heavy	1321-3R500-C	1321-3RA500-C	1321-3R500-C	1321-3RA500-C
250	–	Normal/Heavy	1321-3R500-C	1321-3RA500-C	1321-3R500-C	1321-3RA500-C
270	–	Normal/Heavy	1321-3R500-C	1321-3RA500-C	1321-3R500-C	1321-3RA500-C
–	400	Light/Normal/Heavy	1321-3R500-C	1321-3RA500-C	1321-3R500-C	1321-3RA500-C
315	–	Light/Normal/Heavy	1321-3R600-C	1321-3RA600-C	1321-3R600-C	1321-3RA600-C
336	450	Normal/Heavy	1321-3RA600-C	1321-3RA600-C	1321-3R500-C	1321-3RA500-C
–	450	Light/Normal/Heavy	1321-3R600-C	1321-3RA600-C	1321-3R600-C	1321-3RA600-C
355	–	Light/Normal/Heavy	1321-3R750-C	1321-3RA750-C	1321-3R750-C	1321-3RA750-C
–	500	Light	1321-3R600-C	1321-3RA600-C	1321-3R600-C	1321-3RA600-C
		Normal/Heavy	1321-3R750-C	1321-3RA750-C	1321-3R750-C	1321-3RA750-C
400	–	Light/Heavy	1321-3R750-C	1321-3RA750-C	1321-3R750-C	1321-3RA750-C
		Normal	1321-3R850-C	1321-3RA850-C	1321-3R850-C	1321-3RA850-C

kW	Hp	Duty	Input Line Reactor		Output Load Reactor	
			IP00 (Open Style)	IP11 (NEMA/UL Type 1)	IP00 (Open Style)	IP11 (NEMA/UL Type 1)
			Cat. No.	Cat. No.	Cat. No.	Cat. No.
–	600	Light/Normal/Heavy	1321-3R750-C	1321-3RA750-C	1321-3R750-C	1321-3RA750-C
450	–	Light	1321-3R850-C	1321-3RA850-C	1321-3R850-C	1321-3RA850-C
500	–	Normal/Heavy	1321-3R1000-C	1321-3RA1000-C	1321-3R1000-C	1321-3RA1000-C
–	650	Light	1321-3R850-C	1321-3RA850-C	1321-3R850-C	1321-3RA850-C
–	–	Normal	1321-3R750-C	1321-3RA750-C	1321-3R750-C	1321-3RA750-C
–	700	Light/Normal/Heavy	1321-3R850-C	1321-3RA850-C	1321-3R850-C	1321-3RA850-C
–	750	Heavy	1321-3R850-C	1321-3RA850-C	1321-3R850-C	1321-3RA850-C
–	800	Light/Normal/Heavy	1321-3R1000-C	1321-3RA1000-C	1321-3R1000-C	1321-3RA1000-C
560	–	Light/Normal/Heavy	1321-3R600-C ⁽¹⁾	1321-3RA600-C ⁽¹⁾	1321-3R600-C ⁽¹⁾	1321-3RA600-C ⁽¹⁾
630	–	Light/Normal/Heavy	1321-3R600-C ⁽¹⁾	1321-3RA600-C ⁽¹⁾	1321-3R600-C ⁽¹⁾	1321-3RA600-C ⁽¹⁾
–	900	Light/Normal/Heavy	1321-3R600-C ⁽¹⁾	1321-3RA600-C ⁽¹⁾	1321-3R600-C ⁽¹⁾	1321-3RA600-C ⁽¹⁾
710	–	Light/Normal/Heavy	1321-3R600-C ⁽¹⁾	1321-3RA600-C ⁽¹⁾	1321-3R600-C ⁽¹⁾	1321-3RA600-C ⁽¹⁾
–	1000	Light/Normal/Heavy	1321-3R600-C ⁽¹⁾	1321-3RA600-C ⁽¹⁾	1321-3R600-C ⁽¹⁾	1321-3RA600-C ⁽¹⁾
–	1100	Light/Normal	1321-3R750-C ⁽¹⁾	1321-3RA750-C ⁽¹⁾	1321-3R750-C ⁽¹⁾	1321-3RA750-C ⁽¹⁾
800	–	Light/Normal	1321-3R750-C ⁽¹⁾	1321-3RA750-C ⁽¹⁾	1321-3R750-C ⁽¹⁾	1321-3RA750-C ⁽¹⁾
850	–	Light/Normal	1321-3R750-C ⁽¹⁾	1321-3RA750-C ⁽¹⁾	1321-3R750-C ⁽¹⁾	1321-3RA750-C ⁽¹⁾
–	1250	Light/Normal	1321-3R750-C ⁽¹⁾	1321-3RA750-C ⁽¹⁾	1321-3R750-C ⁽¹⁾	1321-3RA750-C ⁽¹⁾
900	–	Light	1321-3R850-C ⁽¹⁾	1321-3RA850-C ⁽¹⁾	1321-3R850-C ⁽¹⁾	1321-3RA850-C ⁽¹⁾
–	1350	Light	1321-3R850-C ⁽¹⁾	1321-3RA850-C ⁽¹⁾	1321-3R850-C ⁽¹⁾	1321-3RA850-C ⁽¹⁾
–	1500	Light	1321-3R850-C ⁽²⁾	1321-3RA850-C ⁽²⁾	1321-3R850-C ⁽²⁾	1321-3RA850-C ⁽²⁾
1000	–	Light	1321-3R850-C ⁽²⁾	1321-3RA850-C ⁽²⁾	1321-3R850-C ⁽²⁾	1321-3RA850-C ⁽²⁾
–	2000	Light	1321-3R850-C ⁽²⁾	1321-3RA850-C ⁽²⁾	1321-3R850-C ⁽²⁾	1321-3RA850-C ⁽²⁾
1400	–	Light	1321-3R850-C ⁽²⁾	1321-3RA850-C ⁽²⁾	1321-3R850-C ⁽²⁾	1321-3RA850-C ⁽²⁾

(1) Requires two reactors wired in parallel.

(2) Requires three reactors wired in parallel.

600...690V, 50/60 Hz, Three-Phase, 3% Impedance

kW	Hp	Duty	Input Line Reactor		Output Load Reactor	
			IP00 (Open Style)	IP11 (NEMA/UL Type 1)	IP00 (Open Style)	IP11 (NEMA/UL Type 1)
			Cat. No.	Cat. No.	Cat. No.	Cat. No.
–	0.5	Heavy	1321-3R1-C	1321-3RA1-C	1321-3R1-C	1321-3RA1-C
–	1	Normal	1321-3R2-B	1321-3RA2-B	1321-3R2-A	1321-3RA2-B
		Heavy	1321-3R2-B	1321-3RA2-B	1321-3R4-A	1321-3RA4-A
–	2	Normal	1321-3R4-D	1321-3RA4-D	1321-3R4-C	1321-3RA4-C
		Heavy	1321-3R4-C	1321-3RA4-C	1321-3R4-C	1321-3RA4-C
–	3	Normal/Heavy	1321-3R4-B	1321-3RA4-B	1321-3R4-B	1321-3RA4-B
–	5	Normal/Heavy	1321-3R8-C	1321-3RA8-C	1321-3R8-C	1321-3RA8-C
5.5	–	Heavy	1321-3R12-C	1321-3RA12-C	1321-3R12-C	1321-3RA12-C
–	7.5	Normal/Heavy	1321-3R12-B	1321-3RA12-B	1321-3R12-B	1321-3RA12-B
7.5	–	Normal	1321-3R12-B	1321-3RA12-B	1321-3R12-B	1321-3RA12-B
		Heavy	1321-3R12-C	1321-3RA12-C	1321-3R18-C	1321-3RA18-C
–	10	Normal	1321-3R12-B	1321-3RA12-B	1321-3R12-B	1321-3RA12-B
		Heavy	1321-3R12-B	1321-3RA12-B	1321-3R18-C	1321-3RA18-C
11	–	Normal/Heavy	1321-3R18-C	1321-3RA18-C	1321-3R18-C	1321-3RA18-C
–	15	Normal	1321-3R18-B	1321-3RA18-B	1321-3R18-B	1321-3RA18-B
		Heavy	1321-3R25-B	1321-3RA25-B	1321-3R25-B	1321-3RA25-B
15	–	Normal/Heavy	1321-3R25-C	1321-3RA25-C	1321-3R25-C	1321-3RA25-C
–	20	Normal	1321-3R25-B	1321-3RA25-B	1321-3R25-B	1321-3RA25-B
		Heavy	1321-3R35-B	1321-3RA35-B	1321-3R35-B	1321-3RA35-B
18.5	–	Normal/Heavy	1321-3R25-C	1321-3RA25-C	1321-3R25-C	1321-3RA25-C
–	25	Normal	1321-3R25-B	1321-3RA25-B	1321-3R35-B	1321-3RA35-B
22	–	Normal/Heavy	1321-3R35-C	1321-3RA35-C	1321-3R35-C	1321-3RA35-C
–	30	Normal/Heavy	1321-3R35-B	1321-3RA35-B	1321-3R35-B	1321-3RA35-B
30	–	Normal/Heavy	1321-3R35-C	1321-3RA35-C	1321-3R35-C	1321-3RA35-C
–	40	Normal/Heavy	1321-3R45-B	1321-3RA45-B	1321-3R45-B	1321-3RA45-B
37	–	Normal/Heavy	1321-3R45-B	1321-3RA45-B	1321-3R55-C	1321-3RA55-C
–	50	Normal/Heavy	1321-3R55-B	1321-3RA55-B	1321-3R55-B	1321-3RA55-B
45	–	Normal/Heavy	1321-3R55-B	1321-3RA55-B	1321-3R55-B	1321-3RA55-B
–	60	Normal/Heavy	1321-3R80-B	1321-3RA80-B	1321-3R80-B	1321-3RA80-B
55	–	Normal	1321-3R80-C	1321-3RA80-C	1321-3R80-B	1321-3RA80-B
		Heavy	1321-3R80-B	1321-3RA80-B	1321-3R80-B	1321-3RA80-B
–	75	Normal/Heavy	1321-3R100-B	1321-3RA100-B	1321-3R100-B	1321-3RA100-B
75	–	Normal/Heavy	1321-3R80-B	1321-3RA80-B	1321-3R80-B	1321-3RA80-B
–	100	Normal	1321-3R100-B	1321-3RA100-B	1321-3R100-B	1321-3RA100-B
		Heavy	1321-3R100-B	1321-3RA100-B	1321-3R130-B	1321-3RA130-B
90	–	Normal/Heavy	1321-3R100-B	1321-3RA100-B	1321-3R100-B	1321-3RA100-B
–	125	Normal/Heavy	1321-3R130-B	1321-3RA130-B	1321-3R130-B	1321-3RA130-B
110	–	Normal/Heavy	1321-3R130-C	1321-3RA130-C	1321-3R130-C	1321-3RA130-C
–	150	Normal	1321-3R160-B	1321-3RA160-B	1321-3R160-B	1321-3RA160-B
		Heavy	1321-3R200-B	1321-3RA200-B	1321-3R200-B	1321-3RA200-B
132	–	Normal/Heavy	1321-3R160-C	1321-3RA160-C	1321-3R160-C	1321-3RA160-C
–	200	Normal/Heavy	1321-3R200-B	1321-3RA200-B	1321-3R200-B	1321-3RA200-B
160	–	Normal	1321-3R160-C	1321-3RA160-C	1321-3R160-C	1321-3RA160-C
		Heavy	1321-3R200-C	1321-3RAB200-C	1321-3R200-C	1321-3RAB200-C

kW	Hp	Duty	Input Line Reactor		Output Load Reactor	
			IP00 (Open Style)	IP11 (NEMA/UL Type 1)	IP00 (Open Style)	IP11 (NEMA/UL Type 1)
			Cat. No.	Cat. No.	Cat. No.	Cat. No.
–	250	Normal/Heavy	1321-3R250-B	1321-3RA250-B	1321-3R250-B	1321-3RA250-B
–	300	Normal/Heavy	1321-3RB320-B	1321-3RAB320-B	1321-3RB320-B	1321-3RAB320-B
200	–	Normal	1321-3RB200-C	1321-3RAB200-C	1321-3RB200-C	1321-3RAB200-C
		Heavy	1321-3R200-C	1321-3RAB200-C	1321-3RB250-C	1321-3RAB250-C
		Heavy	1321-3R250-B	1321-3RA250-B	1321-3R250-B	1321-3RA250-B
–	350	Light/Normal/Heavy	1321-3RB400-B	1321-3RAB400-B	1321-3RB400-B	1321-3RAB400-B
250	–	Normal	1321-3RB250-C	1321-3RAB250-C	1321-3RB250-C	1321-3RAB250-C
		Normal/Heavy	1321-3RB320-B	1321-3RAB320-B	1321-3RB320-B	1321-3RAB320-B
–	400	Light/Normal/Heavy	1321-3RB400-B	1321-3RAB400-B	1321-3RB400-B	1321-3RAB400-B
300	–	Heavy	1321-3RB400-B	1321-3RAB400-B	1321-3RB400-B	1321-3RAB400-B
–	450	Light/Normal/Heavy	1321-3R500-B	1321-3RA500-B	1321-3R500-B	1321-3RA500-B
315	–	Light/Normal	1321-3RB400-B	1321-3RAB400-B	1321-3RB400-B	1321-3RAB400-B
–	500	Light/Normal	1321-3R600-B	1321-3RA600-B	1321-3R600-B	1321-3RA600-B
355	–	Light/Normal/Heavy	1321-3R500-B	1321-3RA500-B	1321-3R500-B	1321-3RA500-B
375	–	Heavy	1321-3R500-B	1321-3RA500-B	1321-3R500-B	1321-3RA500-B
400	–	Light/Normal/Heavy	1321-3R500-B	1321-3RA500-B	1321-3R500-B	1321-3RA500-B
450	–	Light/Normal	1321-3R600-B	1321-3RA600-B	1321-3R600-B	1321-3RA600-B
450	–	Heavy	1321-3R600-B	1321-3RA600-B	1321-3R600-B	1321-3RA600-B
500	–	Light/Normal	1321-3R600-B	1321-3RA600-B	1321-3R600-B	1321-3RA600-B
500	–	Heavy	1321-3R600-B	1321-3RA600-B	1321-3R600-B	1321-3RA600-B
530	–	Light	1321-3R600-B	1321-3RA600-B	1321-3R600-B	1321-3RA600-B
–	500	Heavy	1321-3R600-B	1321-3RA600-B	1321-3R600-B	1321-3RA600-B
–	550	Light	1321-3R600-B	1321-3RA600-B	1321-3R600-B	1321-3RA600-B
–	600	Normal/Heavy	1321-3R600-B	1321-3RA600-B	1321-3R600-B	1321-3RA600-B
–	700	Light/Normal/Heavy	1321-3R750-B	1321-3RA750-B	1321-3R750-B	1321-3RA750-B
560	–	Normal/Heavy	1321-3R750-B	1321-3RA750-B	1321-3R750-B	1321-3RA750-B
–	750	Heavy	1321-3R750-B	1321-3RA750-B	1321-3R750-B	1321-3RA750-B
630	–	Light/Normal/Heavy	1321-3R750-B	1321-3RA750-B	1321-3R750-B	1321-3RA750-B
–	800	Light/Normal/Heavy	1321-3R850-B	1321-3RA850-B	1321-3R850-B	1321-3RA850-B
710	–	Light/Normal/Heavy	1321-3R850-B	1321-3RA850-B	1321-3R850-B	1321-3RA850-B
–	900	Light/Normal/Heavy	1321-3R850-B	1321-3RA850-B	1321-3R850-B	1321-3RA850-B
750	–	Normal	1321-3R850-B	1321-3RA850-B	1321-3R850-B	1321-3RA850-B
–	950	Light/Normal	1321-3R1000-B	1321-3RA1000-B	1321-3R1000-B	1321-3RA1000-B
800	–	Light/Normal/Heavy	1321-3R1000-B	1321-3RA1000-B	1321-3R1000-B	1321-3RA1000-B
–	1000	Light/Normal	1321-3R1000-B	1321-3RA1000-B	1321-3R1000-B	1321-3RA1000-B
850	–	Light	1321-3R1000-B	1321-3RA1000-B	1321-3R1000-B	1321-3RA1000-B
–	1100	Light	1321-3R600-B ⁽¹⁾	1321-3RA600-B ⁽¹⁾	1321-3R600-B ⁽¹⁾	1321-3RA600-B ⁽¹⁾
900	–	Light/Normal	1321-3R600-B ⁽¹⁾	1321-3RA600-B ⁽¹⁾	1321-3R600-B ⁽¹⁾	1321-3RA600-B ⁽¹⁾
1000	–	Light	1321-3R600-B ⁽¹⁾	1321-3RA600-B ⁽¹⁾	1321-3R600-B ⁽¹⁾	1321-3RA600-B ⁽¹⁾
1100	–	Light/Normal	1321-3R600-B ⁽²⁾	1321-3RA600-B ⁽²⁾	1321-3R600-B ⁽²⁾	1321-3RA600-B ⁽²⁾
–	1200	Light	1321-3R600-B ⁽²⁾	1321-3RA600-B ⁽²⁾	1321-3R600-B ⁽²⁾	1321-3RA600-B ⁽²⁾
1500	–	Light/Normal	1321-3R600-B ⁽²⁾	1321-3RA600-B ⁽²⁾	1321-3R600-B ⁽²⁾	1321-3RA600-B ⁽²⁾
–	1500	Light	1321-3R600-B ⁽²⁾	1321-3RA600-B ⁽²⁾	1321-3R600-B ⁽²⁾	1321-3RA600-B ⁽²⁾

(1) Requires two reactors wired in parallel.
 (2) Requires three reactors wired in parallel.

600...690V, 50/60 Hz, Three-Phase, 5% Impedance

kW	Hp	Duty	Input Line Reactor		Output Load Reactor	
			IP00 (Open Style)	IP11 (NEMA/UL Type 1)	IP00 (Open Style)	IP11 (NEMA/UL Type 1)
			Cat. No.	Cat. No.	Cat. No.	Cat. No.
–	0.5	Heavy	1321-3R1-C	1321-3RA1-C	1321-3R1-C	1321-3RA1-C
–	1	Normal	1321-3R2-C	1321-3RA2-C	1321-3R2-C	1321-3RA2-C
–		Heavy	1321-3R4-D	1321-3RA4-D	1321-3R2-D	1321-3RA4-D
–	2	Normal/Heavy	1321-3R4-D	1321-3RA4-D	1321-3R4-D	1321-3RA4-D
–	3	Normal/Heavy	1321-3R4-D	1321-3RA4-D	1321-3R4-D	1321-3RA4-D
–	5	Normal/Heavy	1321-3R8-D	1321-3RA8-D	1321-3R8-D	1321-3RA8-D
5.5	–	Heavy	1321-3R12-C	1321-3RA12-C	1321-3R12-C	1321-3RA12-C
–	7.5	Normal/Heavy	1321-3R12-C	1321-3RA12-C	1321-3R12-C	1321-3RA12-C
7.5	–	Normal/Heavy	1321-3R12-C	1321-3RA12-C	1321-3R12-C	1321-3RA12-C
–	10	Normal/Heavy	1321-3R12-C	1321-3RA12-C	1321-3R12-C	1321-3RA12-C
11	–	Normal/Heavy	1321-3R18-C	1321-3RA18-C	1321-3R18-C	1321-3RA18-C
–	15	Normal/Heavy	1321-3R18-C	1321-3RA18-C	1321-3R18-C	1321-3RA18-C
15	–	Normal/Heavy	1321-3R25-C	1321-3RA25-C	1321-3R25-C	1321-3RA25-C
–	20	Normal/Heavy	1321-3R25-C	1321-3RA25-C	1321-3R25-C	1321-3RA25-C
18.5	–	Normal/Heavy	1321-3R25-C	1321-3RA25-C	1321-3R25-C	1321-3RA25-C
–	25	Normal/Heavy	1321-3R35-C	1321-3RA35-C	1321-3R35-C	1321-3RA35-C
22	–	Normal/Heavy	1321-3R35-C	1321-3RA35-C	1321-3R35-C	1321-3RA35-C
–	30	Normal	1321-3R35-C	1321-3RA35-C	1321-3R35-C	1321-3RA35-C
–		Heavy	1321-3R45-C	1321-3RA45-C	1321-3R45-C	1321-3RA45-C
30	–	Normal/Heavy	1321-3R35-C	1321-3RA35-C	1321-3R35-C	1321-3RA35-C
–	40	Normal/Heavy	1321-3R45-C	1321-3RA45-C	1321-3R45-C	1321-3RA45-C
37	–	Normal/Heavy	1321-3R45-C	1321-3RA45-C	1321-3R45-C	1321-3RA45-C
–	50	Normal/Heavy	1321-3R55-C	1321-3RA55-C	1321-3R55-C	1321-3RA55-C
45	–	Normal/Heavy	1321-3R55-C	1321-3RA55-C	1321-3R55-C	1321-3RA55-C
–	60	Normal/Heavy	1321-3R80-C	1321-3RA80-C	1321-3R80-C	1321-3RA80-C
55	–	Normal/Heavy	1321-3R80-C	1321-3RA80-C	1321-3R80-C	1321-3RA80-C
–	75	Normal/Heavy	1321-3R100-C	1321-3RA100-C	1321-3R100-C	1321-3RA100-C
75	–	Normal	1321-3R80-C	1321-3RA80-C	1321-3R80-C	1321-3RA80-C
–	–	Heavy	1321-3R80-C	1321-3RA80-C	1321-3R100-C	1321-3RA100-C
–	100	Normal/Heavy	1321-3R100-C	1321-3RA100-C	1321-3R100-C	1321-3RA100-C
90	–	Normal/Heavy	1321-3R100-C	1321-3RA100-C	1321-3R100-C	1321-3RA100-C
–	125	Normal/Heavy	1321-3R130-C	1321-3RA130-C	1321-3R130-C	1321-3RA130-C
110	–	Normal/Heavy	1321-3R130-C	1321-3RA130-C	1321-3R130-C	1321-3RA130-C
132	–	Normal/Heavy	1321-3R160-C	1321-3RA160-C	1321-3R160-C	1321-3RA160-C
–	150	Normal/Heavy	1321-3R160-C	1321-3RA160-C	1321-3R160-C	1321-3RA160-C
160	–	Normal	1321-3R160-C	1321-3RA160-C	1321-3R160-C	1321-3RA160-C
–	–	Heavy	1321-3RB200-C	1321-3RAB200-C	1321-3RB200-C	1321-3RAB200-C
–	200	Normal/Heavy	1321-3R200-C	1321-3RA200-C	1321-3R200-C	1321-3RA200-C
200	–	Normal	1321-3RB200-C	1321-3RAB200-C	1321-3RB200-C	1321-3RAB200-C
–	–	Heavy	1321-3RB200-C	1321-3RAB200-C	1321-3RB250-C	1321-3RAB250-C
–	–	Heavy	1321-3R250-C	1321-3RA250-C	1321-3R250-C	1321-3RA250-C
–	250	Normal/Heavy	1321-3RB250-C	1321-3RAB250-C	1321-3RB250-C	1321-3RAB250-C
–	300	Normal/Heavy	1321-3RB320-C	1321-3RAB320-C	1321-3RB320-C	1321-3RAB320-C
250	–	Normal/Heavy	1321-3RB320-C	1321-3RAB320-C	1321-3RB320-C	1321-3RAB320-C
–	350	Light/Normal/Heavy	1321-3RB400-C	1321-3RAB400-C	1321-3RB400-C	1321-3RAB400-C
–	400	Light/Normal/Heavy	1321-3RB400-C	1321-3RAB400-C	1321-3RB400-C	1321-3RAB400-C

kW	Hp	Duty	Input Line Reactor		Output Load Reactor	
			IP00 (Open Style)	IP11 (NEMA/UL Type 1)	IP00 (Open Style)	IP11 (NEMA/UL Type 1)
			Cat. No.	Cat. No.	Cat. No.	Cat. No.
300	–	Heavy	1321-3RB400-C	1321-3RAB400-C	1321-3RB400-C	1321-3RAB400-C
–	450	Light/Normal/Heavy	1321-3R500-C	1321-3RA500-C	1321-3R500-C	1321-3RA500-C
315	–	Light/Normal	1321-3RB400-C	1321-3RAB400-C	1321-3RB400-C	1321-3RAB400-C
–	500	Light/Normal/Heavy	1321-3R600-C	1321-3RA600-C	1321-3R600-C	1321-3RA600-C
355	–	Light/Normal/Heavy	1321-3R500-C	1321-3RA500-C	1321-3R500-C	1321-3RA500-C
–	550	Light	1321-3R600-C	1321-3RA600-C	1321-3R600-C	1321-3RA600-C
375	–	Heavy	1321-3R500-C	1321-3RA500-C	1321-3R500-C	1321-3RA500-C
400	–	Light/Normal/Heavy	1321-3R500-C	1321-3RA500-C	1321-3R500-C	1321-3RA500-C
450	–	Light/Normal/Heavy	1321-3R600-C	1321-3RA600-C	1321-3R600-C	1321-3RA600-C
500	–	Light/Normal	1321-3R600-C	1321-3RA600-C	1321-3R600-C	1321-3RA600-C
500	–	Heavy	1321-3R600-C	1321-3RA600-C	1321-3R600-C	1321-3RA600-C
530	–	Light	1321-3R600-C	1321-3RA600-C	1321-3R600-C	1321-3RA600-C
–	600	Normal/Heavy	1321-3R600-C	1321-3RA600-C	1321-3R600-C	1321-3RA600-C
–	700	Light/Normal/Heavy	1321-3R750-C	1321-3RA750-C	1321-3R750-C	1321-3RA750-C
560	–	Normal/Heavy	1321-3R750-C	1321-3RA750-C	1321-3R750-C	1321-3RA750-C
–	750	Heavy	1321-3R750-C	1321-3RA750-C	1321-3R750-C	1321-3RA750-C
630	–	Light/Normal/Heavy	1321-3R750-C	1321-3RA750-C	1321-3R750-C	1321-3RA750-C
–	800	Light/Normal/Heavy	1321-3R850-C	1321-3RA850-C	1321-3R850-C	1321-3RA850-C
710	–	Light/Normal/Heavy	1321-3R850-C	1321-3RA850-C	1321-3R850-C	1321-3RA850-C
–	900	Light/Normal/Heavy	1321-3R850-C	1321-3RA850-C	1321-3R850-C	1321-3RA850-C
750	–	Normal	1321-3R850-C	1321-3RA850-C	1321-3R850-C	1321-3RA850-C
–	950	Light/Normal	1321-3R1000-C	1321-3RA1000-C	1321-3R1000-C	1321-3RA1000-C
800	–	Light/Normal/Heavy	1321-3R1000-C	1321-3RA1000-C	1321-3R1000-C	1321-3RA1000-C
–	1000	Light/Normal	1321-3R1000-C	1321-3RA1000-C	1321-3R1000-C	1321-3RA1000-C
850	–	Light	1321-3R1000-C	1321-3RA1000-C	1321-3R1000-C	1321-3RA1000-C
–	1100	Light	1321-3R600-C ⁽¹⁾	1321-3RA600-C ⁽¹⁾	1321-3R600-C ⁽¹⁾	1321-3RA600-C ⁽¹⁾
900	–	Light/Normal	1321-3R600-C ⁽¹⁾	1321-3RA600-C ⁽¹⁾	1321-3R600-C ⁽¹⁾	1321-3RA600-C ⁽¹⁾
1000	–	Light	1321-3R600-C ⁽¹⁾	1321-3RA600-C ⁽¹⁾	1321-3R600-C ⁽¹⁾	1321-3RA600-C ⁽¹⁾
1100	–	Light/Normal	1321-3R600-C ⁽²⁾	1321-3RA600-C ⁽²⁾	1321-3R600-C ⁽²⁾	1321-3RA600-C ⁽²⁾
–	1200	Light	1321-3R600-C ⁽²⁾	1321-3RA600-C ⁽²⁾	1321-3R600-C ⁽²⁾	1321-3RA600-C ⁽²⁾
1500	–	Light/Normal	1321-3R600-C ⁽²⁾	1321-3RA600-C ⁽²⁾	1321-3R600-C ⁽²⁾	1321-3RA600-C ⁽²⁾
–	1500	Light	1321-3R600-C ⁽²⁾	1321-3RA600-C ⁽²⁾	1321-3R600-C ⁽²⁾	1321-3RA600-C ⁽²⁾

(1) Requires two reactors wired in parallel.

(2) Requires three reactors wired in parallel.

Notes:

Important Information

Solid-state equipment has operational characteristics differing from those of electromechanical equipment. Safety Guidelines for the Application, Installation and Maintenance of Solid State Controls (publication [SGI-1.1](#) available from your local Rockwell Automation sales office or online at <http://www.rockwellautomation.com/literature/>) describes some important differences between solid-state equipment and hard-wired electromechanical devices. Because of this difference, and also because of the wide variety of uses for solid-state equipment, all persons responsible for applying this equipment must satisfy themselves that each intended application of this equipment is acceptable.

In no event will Rockwell Automation, Inc. be responsible or liable for indirect or consequential damages resulting from the use or application of this equipment.

The examples and diagrams in this publication are included solely for illustrative purposes. Because of the many variables and requirements associated with any particular installation, Rockwell Automation, Inc. cannot assume responsibility or liability for actual use based on the examples and diagrams.

No patent liability is assumed by Rockwell Automation, Inc. with respect to use of information, circuits, equipment, or software described in this manual.

Reproduction of the contents of this manual, in whole or in part, without written permission of Rockwell Automation, Inc., is prohibited.

Documentation Feedback

Your comments will help us serve your documentation needs better. If you have any suggestions on how to improve this document, complete this form, publication [RA-DU002](#), available at <http://www.rockwellautomation.com/literature/>.

Allen-Bradley, Rockwell Software, Rockwell Automation, Silver Series, and TechConnect are trademarks of Rockwell Automation, Inc.
Trademarks not belonging to Rockwell Automation are property of their respective companies.

www.rockwellautomation.com

Power, Control and Information Solutions Headquarters

Americas: Rockwell Automation, 1201 South Second Street, Milwaukee, WI 53204-2496 USA, Tel: (1) 414.382.2000, Fax: (1) 414.382.4444
Europe/Middle East/Africa: Rockwell Automation NV, Pegasus Park, De Kleetlaan 12a, 1831 Diegem, Belgium, Tel: (32) 2 663 0600, Fax: (32) 2 663 0640
Asia Pacific: Rockwell Automation, Level 14, Core F, Cyberport 3, 100 Cyberport Road, Hong Kong, Tel: (852) 2887 4788, Fax: (852) 2508 1846

Publication 750-TD0011-EN-P - February 2016

Supersedes Publication 750-TD0011H-EN-P - June 2013

Copyright © 2016 Rockwell Automation, Inc. All rights reserved. Printed in the U.S.A.