



# POINT I/O 2 and 4 Relay Output Modules

Catalog numbers 1734-OW2, 1734-OW4, Series C

## Table of Contents

<b>Topic</b>	<b>Page</b>
Important User Information	2
Environment and Enclosure	3
Preventing Electrostatic Discharge	3
North American Hazardous Location Approval	5
Additional Resources	6
About the Module	7
Mount the I/O Base	9
Install the Module	10
Install the Removable Terminal Block	11
Remove a Mounting Base	12
Communicate with Your Module	13
Wire the Module	14
Interpret Status Indicators	18
Specifications	20

### Important User Information

Solid-state equipment has operational characteristics differing from those of electromechanical equipment. Safety Guidelines for the Application, Installation and Maintenance of Solid State Controls (Publication SGI-1.1 available from your local Rockwell Automation sales office or online at <http://www.rockwellautomation.com/literature/>) describes some important differences between solid-state equipment and hard-wired electromechanical devices. Because of this difference, and also because of the wide variety of uses for solid-state equipment, all persons responsible for applying this equipment must satisfy themselves that each intended application of this equipment is acceptable.





In no event will Rockwell Automation, Inc. be responsible or liable for indirect or consequential damages resulting from the use or application of this equipment.

The examples and diagrams in this manual are included solely for illustrative purposes. Because of the many variables and requirements associated with any particular installation, Rockwell Automation, Inc. cannot assume responsibility or liability for actual use based on the examples and diagrams.

No patent liability is assumed by Rockwell Automation, Inc. with respect to use of information, circuits, equipment, or software described in this manual.

Reproduction of the contents of this manual, in whole or in part, without written permission of Rockwell Automation, Inc., is prohibited.

Throughout this manual, when necessary, we use notes to make you aware of safety considerations.

	<b>WARNING:</b> Identifies information about practices or circumstances that can cause an explosion in a hazardous environment, which may lead to personal injury or death, property damage, or economic loss.
	<b>ATTENTION:</b> Identifies information about practices or circumstances that can lead to personal injury or death, property damage, or economic loss. Attentions help you identify a hazard, avoid a hazard and recognize the consequences.
	<b>SHOCK HAZARD:</b> Labels may be on or inside the equipment (for example, drive or motor) to alert people that dangerous voltage may be present.
	<b>BURN HAZARD:</b> Labels may be on or inside the equipment (for example, drive or motor) to alert people that surfaces may reach dangerous temperatures.
<b>IMPORTANT</b>	Identifies information that is critical for successful application and understanding of the product.

---

## Environment and Enclosure

---



**ATTENTION:** This equipment is intended for use in a Pollution Degree 2 industrial environment, in overvoltage Category II applications (as defined in IEC 60664-1), at altitudes up to 2000 m (6562 ft) without derating.

This equipment is considered Group 1, Class A industrial equipment according to IEC/CISPR 11. Without appropriate precautions, there may be difficulties with electromagnetic compatibility in residential and other environments due to conducted and radiated disturbances.

This equipment is supplied as open-type equipment. It must be mounted within an enclosure that is suitably designed for those specific environmental conditions that will be present and appropriately designed to prevent personal injury resulting from accessibility to live parts. The enclosure must have suitable flame-retardant properties to prevent or minimize the spread of flame, complying with a flame spread rating of 5VA or be approved for the application if nonmetallic. The interior of the enclosure must be accessible only by the use of a tool. Subsequent sections of this publication may contain additional information regarding specific enclosure type ratings that are required to comply with certain product safety certifications.

In addition to this publication, see:

- Industrial Automation Wiring and Grounding Guidelines, publication [1770-4.1](#), for additional installation requirements.
- NEMA Standard 250 and IEC 60529, as applicable, for explanations of the degrees of protection provided by enclosures.

---

## Preventing Electrostatic Discharge

---



**ATTENTION:** This equipment is sensitive to electrostatic discharge which can cause internal damage and affect normal operation. Follow these guidelines when you handle this equipment.

- Touch a grounded object to discharge potential static.
- Wear an approved grounding wrist strap.
- Do not touch connectors or pins on component boards.
- Do not touch circuit components inside the equipment.
- Use a static-safe workstation if available.
- Store the equipment in appropriate static-safe packaging when not in use.

## 4 POINT I/O 2 and 4 Relay Output Modules

---

### European Hazardous Location Approval

---

#### European Zone 2 Certification (The following applies when the product bears the Ex Marking)

This equipment is intended for use in potentially explosive atmospheres as defined by European Union Directive 94/9/EC.

DEMKO certifies that this equipment has been found to comply with the Essential Health and Safety Requirements relating to the design and construction of Category 3 equipment intended for use in Zone 2 potentially explosive atmospheres, given in Annex II to this Directive.

Compliance with the Essential Health and Safety Requirements has been assured by compliance with EN 60079-15.

---



**ATTENTION:** This equipment is not resistant to sunlight or other sources of UV radiation.

**ATTENTION:** POINT I/O is grounded through the DIN rail to chassis ground. Use zinc plated yellow-chromate steel DIN rail to assure proper grounding. The use of other DIN rail materials (for example, aluminum or plastic) that can corrode, oxidize, or are poor conductors, can result in improper or intermittent grounding. Secure DIN rail to mounting surface approximately every 200 mm (7.8 in.) and use end-anchors appropriately.

---



**WARNING:** This equipment must be installed in an enclosure providing at least IP54 protection when applied in Class I, Zone 2 environments.

**WARNING:** This equipment shall be used within its specified ratings defined by Rockwell Automation.

**WARNING:** Provision shall be made to prevent the rated voltage from being exceeded by transient disturbances of more than 40% when applied in Class I, Zone 2 environments.

**WARNING:** Do not disconnect equipment unless power has been removed or the area is known to be nonhazardous.



**WARNING:** Exposure to some chemicals may degrade the sealing properties of materials used in the following devices:

Relay K2 and K4, Epoxy for 1734-OW2, and Relay K1 through K4, Epoxy for 1734-OW4.

It is recommended that the User periodically inspect these devices for any degradation of properties and replace the module if degradation is found.

---

## North American Hazardous Location Approval

<p><b>The following information applies when operating this equipment in hazardous locations:</b></p>	<p><b>Informations sur l'utilisation de cet équipement en environnements dangereux:</b></p>
<p>Products marked "CL I, DIV 2, GP A, B, C, D" are suitable for use in Class I Division 2 Groups A, B, C, D, Hazardous Locations and nonhazardous locations only. Each product is supplied with markings on the rating nameplate indicating the hazardous location temperature code. When combining products within a system, the most adverse temperature code (lowest "T" number) may be used to help determine the overall temperature code of the system. Combinations of equipment in your system are subject to investigation by the local Authority Having Jurisdiction at the time of installation.</p>	<p>Les produits marqués "CL I, DIV 2, GP A, B, C, D" ne conviennent qu'à une utilisation en environnements de Classe I Division 2 Groupes A, B, C, D dangereux et non dangereux. Chaque produit est livré avec des marquages sur sa plaque d'identification qui indiquent le code de température pour les environnements dangereux. Lorsque plusieurs produits sont combinés dans un système, le code de température le plus défavorable (code de température le plus faible) peut être utilisé pour déterminer le code de température global du système. Les combinaisons d'équipements dans le système sont sujettes à inspection par les autorités locales qualifiées au moment de l'installation.</p>
<div style="display: flex; align-items: center;">  <div> <p><b>WARNING: EXPLOSION HAZARD</b></p> <ul style="list-style-type: none"> <li>• Do not disconnect equipment unless power has been removed or the area is known to be nonhazardous.</li> <li>• Do not disconnect connections to this equipment unless power has been removed or the area is known to be nonhazardous. Secure any external connections that mate to this equipment by using screws, sliding latches, threaded connectors, or other means provided with this product.</li> <li>• Substitution of components may impair suitability for Class I, Division 2.</li> <li>• If this product contains batteries, they must only be changed in an area known to be nonhazardous.</li> </ul> </div> </div>	<div style="display: flex; align-items: center;">  <div> <p><b>AVERTISSEMENT: RISQUE D'EXPLOSION</b></p> <ul style="list-style-type: none"> <li>• Couper le courant ou s'assurer que l'environnement est classé non dangereux avant de débrancher l'équipement.</li> <li>• Couper le courant ou s'assurer que l'environnement est classé non dangereux avant de débrancher les connecteurs. Fixer tous les connecteurs externes reliés à cet équipement à l'aide de vis, loquets coulissants, connecteurs filetés ou autres moyens fournis avec ce produit.</li> <li>• La substitution de composants peut rendre cet équipement inadapté à une utilisation en environnement de Classe I, Division 2.</li> <li>• S'assurer que l'environnement est classé non dangereux avant de changer les piles.</li> </ul> </div> </div>

## Additional Resources

These documents contain additional information concerning related Rockwell Automation products.

<b>Resource</b>	<b>Description</b>
1769-L32E and 1769-L35E CompactLogix Controller Installation Instructions, publication <a href="#">1768-IN020</a> .	Provides details on how to assemble and mount the controller, how to upgrade firmware, and controller technical specifications.
1769-L32C and 1769-L35CR CompactLogix Controller Installation Instructions, publication <a href="#">1769-IN070</a> .	Provides details on how to assemble and mount the controller, how to upgrade firmware, and controller technical specifications.
1769-L31 CompactLogix Controller Installation Instructions, publication <a href="#">1769-IN069</a> .	Provides details on how to assemble and mount the controller, how to upgrade firmware, and controller technical specifications.
1769-SDN Compact I/O DeviceNet Scanner Module Installation Instructions, publication <a href="#">1769-IN060</a> .	Provides information about installing the 1769-SDN module and technical specifications.
Industrial Automation Wiring and Grounding Guidelines, publication <a href="#">1770-4.1</a> .	Provides general guidelines for installing a Rockwell Automation industrial system.
Product Certifications website <a href="http://www.ab.com">http://www.ab.com</a> .	Provides declarations of conformity, certificates, and other certification details.

## About the Module

These POINT™ I/O 2 and 4 Relay Output Modules, 1734-OW2, 1734-OW4, Series C products can be used with DeviceNet and PROFIBUS adapters. They can be used with ControlNet and Ethernet adapters using RSLogix 5000, version 11 or later.

See the figures to familiarize yourself with major parts of the modules. The wiring base assembly consists of a mounting base, 1734-MB, and removable terminal block, 1734-RTB or 1734-RTBS, and 1734-TOP or 1734-TOPS one-piece terminal base.

### Modules Mounted on Removeable Terminal Block and Mounting Base

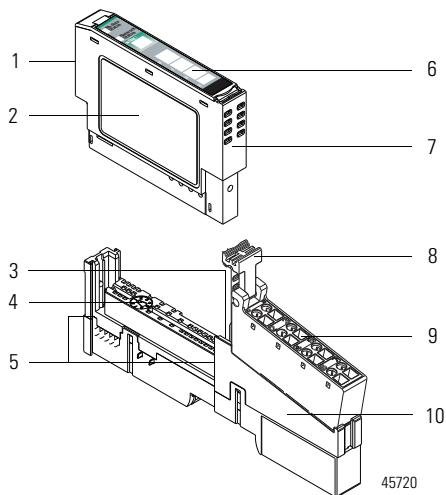

	Description		Description
1	Module locking mechanism	6	Slide-in writable label
2	Module wiring diagram	7	Insertable I/O module
3	DIN rail locking screw (orange)	8	Removable terminal block handle
4	Mechanical keying	9	Removable terminal block (RTB)
5	Interlocking side pieces	10	Mounting base

**Modules Mounted on 1734-TOP or 1734-TOPS One-piece Terminal Base**

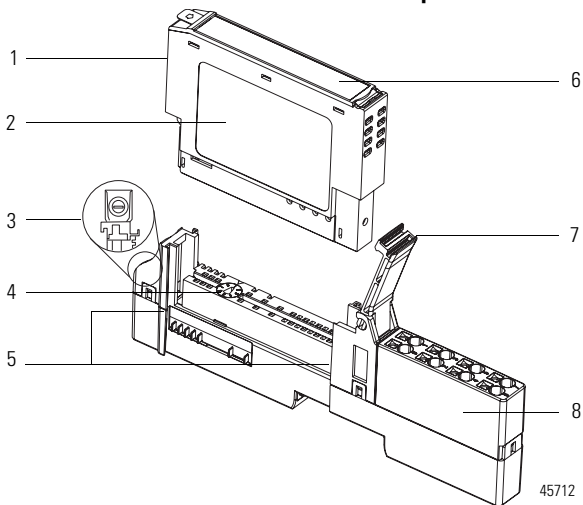

	<b>Description</b>		<b>Description</b>
1	Module locking mechanism	5	Interlocking side pieces
2	Module wiring diagram	6	Slide-in writable label
3	DIN rail locking screw (orange)	7	Handle
4	Mechanical keying	8	1734-TOP or 1734-TOPS one-piece terminal base with screw or spring clamp

## Mount the I/O Base

To mount the I/O base on the DIN rail, proceed as follows:

1. Position the mounting base vertically above the installed units (adapter, power supply or existing module).

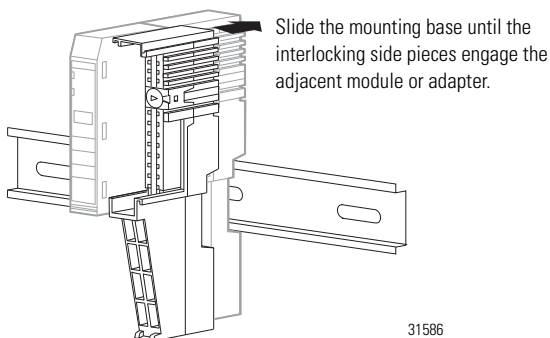

2. Slide the mounting base down allowing the interlocking side pieces to engage the adjacent module or adapter.
3. Press firmly to seat the mounting base on the DIN rail. The mounting base snaps into place.

## Install the Module

The module can be installed before or after base installation. Make sure that the mounting base is correctly keyed before installing the module into the mounting base. In addition, make sure the mounting base locking screw is positioned horizontal in reference to the base.

1. Using a bladed screwdriver to rotate the keyswitch on the mounting base clockwise until the number required for the type of module being installed aligns with the notch in the base.
2. Make certain the DIN rail locking screw is in the horizontal position. You cannot insert the module if the locking mechanism is unlocked.
3. Insert the module straight down into the mounting base and press to secure. The module locks into place.

Turn the keyswitch to align the number with the notch. Notch position 3 is shown.

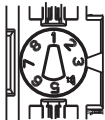

Make sure the DIN rail locking screw is in the horizontal position.

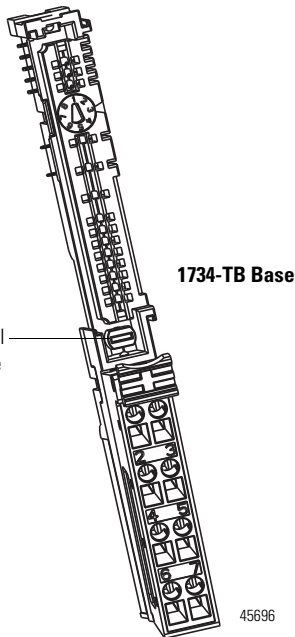

Turn the keyswitch to align the number with the notch. Notch position 1 is shown.

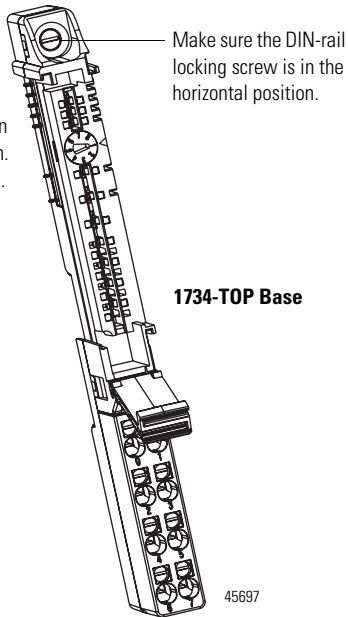
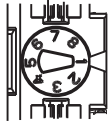

**WARNING:** When you insert or remove the module while backplane power is on, an electrical arc can occur. This could cause an explosion in hazardous location installations.

Be sure that power is removed or the area is nonhazardous before proceeding.

## Install the Removable Terminal Block

A removable terminal block (RTB) is supplied with your wiring base assembly. To remove, pull up on the RTB handle. This allows the mounting base to be removed and replaced as necessary without removing any of the wiring. To reinsert the removable terminal block, proceed as follows:

## 12 POINT I/O 2 and 4 Relay Output Modules

---

1. Insert the end opposite the handle into the base unit. This end has a curved section that engages with the wiring base.
2. Rotate the terminal block into the wiring base until it locks itself in place.
3. If an I/O module is installed, snap the RTB handle into place on the module.

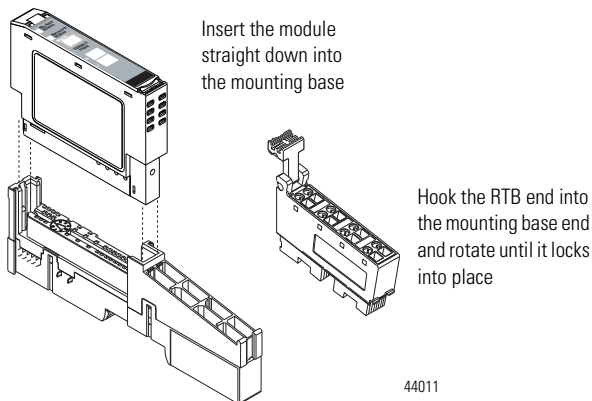

**WARNING:** When you connect or disconnect the Removable Terminal Block (RTB) with field side power applied, an electrical arc can occur. This could cause an explosion in hazardous location installations. Be sure that power is removed or the area is nonhazardous before proceeding.

---

### Remove a Mounting Base

To remove a mounting base, you must remove any installed module, and the module installed in the base to the right. Remove the removable terminal block, if wired.

1. Unlatch the RTB handle on the I/O module.
2. Pull on the RTB handle to remove the removable terminal block.
3. Press on the module lock on the top of the module.
4. Pull on the I/O module to remove from the base.
5. Repeat steps 1, 2, 3 and 4 for the module to the right.

6. Use a small bladed screwdriver to rotate the orange base locking screw to a vertical position. This releases the locking mechanism.
7. Lift straight up to remove.

## Communicate with Your Module

I/O messages are sent to (consumed) and received from (produced) the POINT I/O modules. These messages are mapped onto the processor's memory.

This POINT I/O output module does not produce input data (scanner Rx). It consumes 1 Byte of I/O data (scanner Tx).

### Default Data Map for 1734-OW2

Message size: 1 Byte

	7	6	5	4	3	2	1	0	
Consumes (scanner Tx)	Not used						Ch 1	Ch 0	Channel state

Where: 0 = Off, 1 = On

### Default Data Map for 1734-OW4

Message size: 1 Byte

	7	6	5	4	3	2	1	0	
Consumes (scanner Tx)	Not used				Ch3	Ch2	Ch 1	Ch 0	Channel state

Where: 0 = Off, 1 = On

## Wire the Module

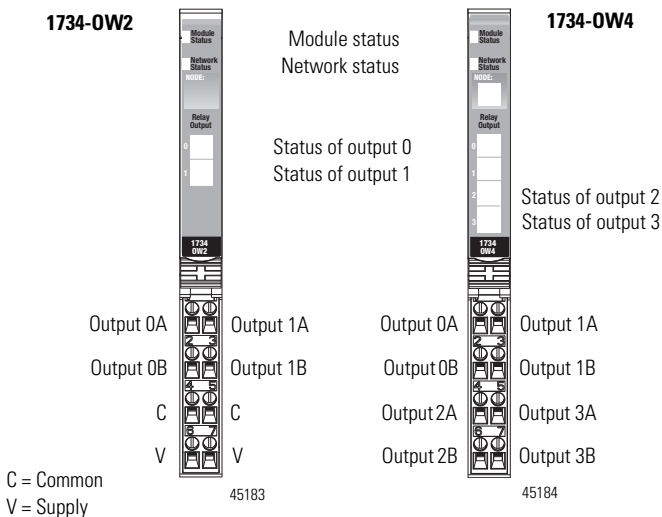

**WARNING:** If you connect or disconnect wiring while the field-side power is on, an electrical arc can occur. This could cause an explosion in hazardous location installations. Be sure that power is removed or the area is nonhazardous before proceeding.

Relay contacts are not directly powered by the internal power bus. Load power from the internal power bus is available for the 1734-OW2 only. Connect to pins 6 and 7 for V supply, and to pins 4 and 5 for V common.

**1734-OW2 – Load Powered by Internal Power Bus**

Out = Output channel relay contacts  
 V = Supply (ranges from 5V DC...240V AC)  
 C = Common

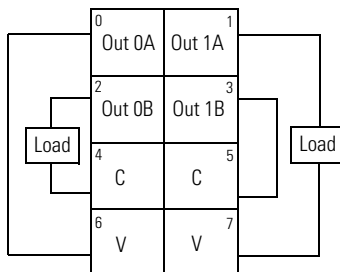
**1734-OW4 – Load Powered by External Power Bus**

Out = Output channel relay contacts

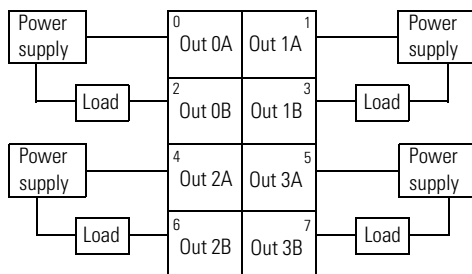

Load power must be provided by an external power source for the 1734-OW4. The 1734-OW4 cannot be powered from the internal power bus.

Channel	Output	Channel	Output
0A	0	2A	4
0B	2	2B	6
1A	1	3A	5
1B	3	3B	7



**ATTENTION:** The power supply voltage may be daisy-chained from a 1734 adapter, 1734-FPD or 1734-EP24DC communication interface. Each channel is individually isolated and may have a unique supply and/or voltage as necessary.

**ATTENTION:** Do not attempt to increase load current or wattage capability beyond the maximum rating by connecting two or more outputs in parallel. The slightest variation in relay switching time may cause one relay to momentarily switch the total load current.

**ATTENTION:** Make sure that all relay wiring is properly connected before applying any power to the module.

**ATTENTION:** Total current draw through the wiring base unit is limited to 10 A. Separate power connections to the terminal base unit may be necessary.

**ATTENTION:** Use the end cap from your adapter or interface module to cover the exposed interconnections on the last mounting base on the DIN rail. Failure to do so could result in equipment damage or injury from electric shock.

### Wire with AC Modules

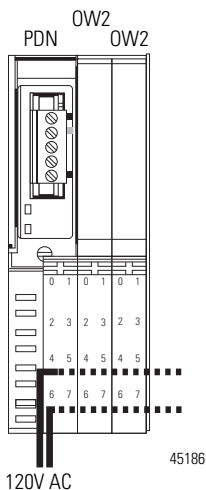

### Wire Using a 1734-FPD

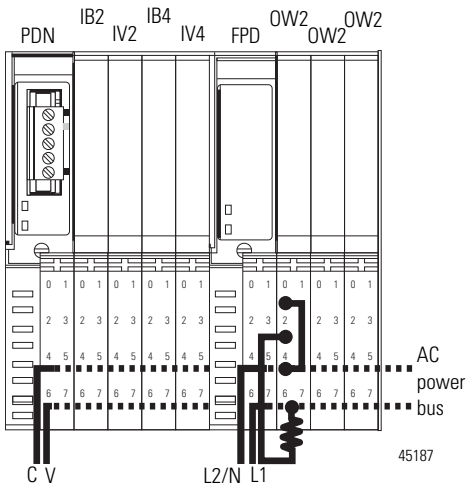

### Wire Using External Power Source for AC Relay Power

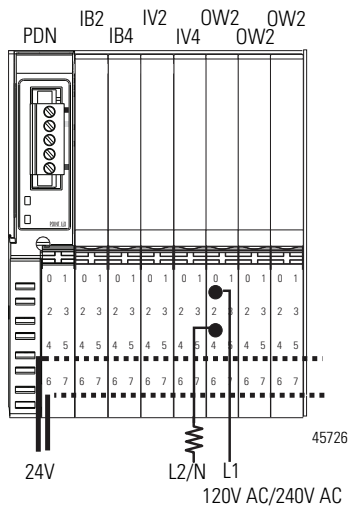

## Interpret Status Indicators

Refer to the following diagram and table for information on how to interpret the status indicators.

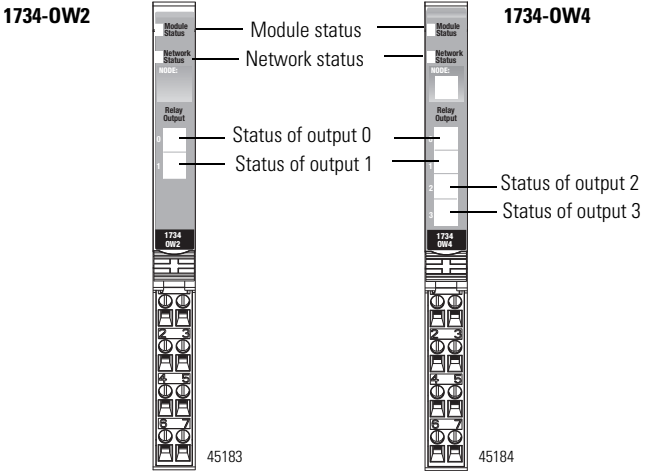

### Indicator Status for Modules

	Status	Description
Module status	Off	No power applied to device.
	Green	Device operating normally.
	Flashing green	Device needs commissioning due to missing, incomplete, or incorrect configuration.
	Flashing red	Recoverable fault.
	Red	Unrecoverable fault occurred. Self-test failure present (checksum failure or ramtest failure at cycle power). Firmware fatal error present.
	Flashing red/green	Device is in self-test mode.

**Indicator Status for Modules**

	<b>Status</b>	<b>Description</b>
Network status	Off	Device is not online: <ul style="list-style-type: none"> <li>- Device has not completed dup_MAC-id test.</li> <li>- Device not powered – check module status indicator.</li> </ul>
	Flashing green	Device is online but has no connections in the established state.
	Green	Device is online and has connections in the established state.
	Flashing red	One or more I/O connections are in timed-out state.
	Red	Critical link failure – failed communication device. Device detected error that prevents it from communicating on the network.
	Flashing red/green	Communication faulted device – the device has detected a network access error and is in communication faulted state. Device has received and accepted an Identity Communication Faulted Request – long protocol message.
I/O status	Off	Outputs off.
	Yellow	Outputs on.

## Specifications

### General Specifications

Attribute	Value
Outputs per module	1734-0W2 – 2 Form A isolated (normally open) electromechanical relays 1734-0W4 – 4 Form A isolated (normally open) electromechanical relays
Off-state leakage current, max	1.2 A @ 240V AC, and bleed resistor through snubber circuit
Terminal base screw torque	Determined by installed terminal block
Power consumption	0.8 W
Power dissipation, max	0.5 W
Backplane power	5V DC, 80 mA
Contact rating	5...30V DC @ 2.0 A resistive 120V AC @ 2.0 A resistive 240V AC @ 2.0 A resistive 1800 VA make, 180 VA break
Isolation voltage	250V (continuous), Basic Insulation Type Type tested @ 2550V DC for 60 s, field-side to system, and between contact sets
Switching frequency, max	1 operation/3 s (0.3 Hz @ rated load)
Expected life of electrical contacts, min	100,000 operations @ rated load
Wiring category <sup>(1)</sup>	1 – on signal ports
Wire size	0.25...2.5 mm <sup>2</sup> (22...14 AWG) solid or stranded copper wire rated at 75 °C (167 °F), or greater, 1.2 mm (3/64 in.) insulation max
Enclosure type rating	None (open-style)
Pilot duty rating	R150
North American temp code	T4A
IEC temp code	T4

<sup>(1)</sup> Use this conductor category information for planning conductor routing as described in Industrial Automation Wiring and Grounding Guidelines, publication [1770-4.1](#).

## Environmental Specifications

Attribute	Value
Temperature, operating	IEC 60068-2-1 (Test Ad, Operating Cold), IEC 60068-2-2 (Test Bd, Operating Dry Heat), IEC 60068-2-14 (Test Nb, Operating Thermal Shock): -20...55 °C (-4...131 °F)
Temperature, surrounding air, max.	55 °C (131 °F)
Temperature, nonoperating	IEC 60068-2-1 (Test Ab, Unpackaged Nonoperating Cold), IEC 60068-2-2 (Test Bb, Unpackaged Nonoperating Dry Heat), IEC 60068-2-14 (Test Na, Unpackaged Nonoperating Thermal Shock): -40...85 °C (-40...185 °F)
Relative humidity	IEC 60068-2-30 (Test Db, Unpackaged Damp Heat): 5...95% noncondensing
Vibration	IEC 60068-2-6, (Test Fc, Operating): 5 g @ 10...500 Hz
Shock, operating	IEC 60068-2-27 (Test Ea, Unpackaged Shock): 30 g
Shock, nonoperating	IEC 60068-2-27 (Test Ea, Unpackaged Shock): 50 g
Emissions	CISPR 11 Group 1, Class A
ESD immunity	IEC 61000-4-2: 6 kV contact discharges 8 kV air discharges
Radiated RF immunity	IEC 61000-4-3: 10V/m with 1 kHz sine-wave 80%AM from 80 MHz...2000 MHz 10V/m with 200 Hz 50% pulse 100%AM @ 900 MHz 10V/m with 200 Hz 50% pulse 100%AM @ 1890 MHz 1V/m with 1 kHz sine-wave 80%AM from 2000...2700 MHz
EFT/B immunity	IEC 61000-4-4: ±4kV @ 2.5 kHz on signal ports
Surge transient immunity	IEC 61000-4-5: ±1 kV line-line (DM) and ±2 kV line-earth (CM) on signal ports
Conducted RF immunity	IEC 61000-4-6: 10V rms with 1 kHz sine-wave 80%AM @ 150 kHz...80 MHz

**Certifications**

<b>Certification (when product is marked)<sup>(1)</sup></b>	<b>Value</b>
c-UL-us	<p>UL Listed Industrial Control Equipment, certified for US and Canada. See UL File E65584.</p> <p>UL Listed for Class I, Division 2 Group A,B,C,D Hazardous Locations, certified for U.S. and Canada. See UL File E194810</p>
CE	<p>European Union 2004/108/EC EMC Directive, compliant with:            EN 61326-1; Meas./Control/Lab., Industrial Requirements            EN 61000-6-2; Industrial Immunity            EN 61000-6-4; Industrial Emissions            EN 61131-2; Programmable Controllers (Clause 8, Zone A &amp; B)</p> <p>European Union 2006/95/EC LVD, compliant with:            EN 61131-2; Programmable Controllers (Clause 11)</p>
C-Tick	<p>Australian Radiocommunications Act, compliant with:            AS/NZS CISPR 11; Industrial Emissions</p>
Ex	<p>European Union 94/9/EC ATEX Directive, compliant with:            EN 60079-15; Potentially Explosive Atmospheres, Protection "n"            EN 60079-0; General Requirements            II 3 G Ex nC IIC T4            when used at or below 60V AC or 75V DC</p>
KC	<p>Korean Registration of Broadcasting and Communications Equipment, compliant with:            Article 58-2 of Radio Waves Act, Clause 3</p>

<sup>(1)</sup> See the Product Certification link at <http://www.ab.com> for Declaration of Conformity, Certificates, and other certification details.



## Rockwell Automation Support

Rockwell Automation provides technical information on the Web to assist you in using its products. At <http://www.rockwellautomation.com/support/>, you can find technical manuals, a knowledge base of FAQs, technical and application notes, sample code and links to software service packs, and a MySupport feature that you can customize to make the best use of these tools.

For an additional level of technical phone support for installation, configuration and troubleshooting, we offer TechConnect support programs. For more information, contact your local distributor or Rockwell Automation representative, or visit <http://www.rockwellautomation.com/support/>.

## Installation Assistance

If you experience a problem within the first 24 hours of installation, please review the information that's contained in this manual. You can also contact a special Customer Support number for initial help in getting your product up and running.

United States or Canada	1.440.646.3434
Outside United States or Canada	Use the <a href="#">Worldwide Locator</a> at <a href="http://www.rockwellautomation.com/support/americas/phone_en.html">http://www.rockwellautomation.com/support/americas/phone_en.html</a> , or contact your local Rockwell Automation representative.

## New Product Satisfaction Return

Rockwell Automation tests all of its products to ensure that they are fully operational when shipped from the manufacturing facility. However, if your product is not functioning and needs to be returned, follow these procedures.

United States	Contact your distributor. You must provide a Customer Support case number (call the phone number above to obtain one) to your distributor to complete the return process.
Outside United States	Please contact your local Rockwell Automation representative for the return procedure.

## Documentation Feedback

Your comments will help us serve your documentation needs better. If you have any suggestions on how to improve this document, complete this form, publication [RA-DU002](#), available at <http://www.rockwellautomation.com/literature/>.

Allen-Bradley, Rockwell Automation, ArmorBlock, and TechConnect are trademarks of Rockwell Automation, Inc.

Trademarks not belonging to Rockwell Automation are property of their respective companies.

Rockwell Otomasyon Ticaret A.Ş., Kar Plaza İş Merkezi E Blok Kat:6 34752 İçerenköy, İstanbul, Tel: +90 (216) 5698400

[www.rockwellautomation.com](http://www.rockwellautomation.com)

### Power, Control and Information Solutions Headquarters

Americas: Rockwell Automation, 1201 South Second Street, Milwaukee, WI 53204-2496 USA, Tel: (1) 414.382.2000, Fax: (1) 414.382.4444  
Europe/Middle East/Africa: Rockwell Automation, Voortaan/Bolevard du Souverain 36, 1170 Brussels, Belgium, Tel: (32) 2 663 0600, Fax: (32) 2 663 0640  
Asia Pacific: Rockwell Automation, Level 14, Core F, Cyberport 3, 100 Cyberport Road, Hong Kong, Tel: (852) 2887 4788, Fax: (852) 2508 1846

Publication 1734-IN055F-EN-E - March 2012